

MECCANO®

BOOK OF MODELS

VOORBEELDENBOEK

LIVRE DES MODÈLES

LIBRO DEI MODELLI

MODELLBUCH

MODELLBOK

LIBRO DE MODELOS

LIVRO DE MODELOS

MODELLBOK

8



- 5 PERFORATED STRIPS**
- | | |
|------------------|---------------|
| 1 - 12½": 32 cm | 3 - 3½": 9 cm |
| 1a - 9½": 24 cm | 4 - 3": 7½ cm |
| 1b - 7½": 19 cm | 5 - 2½": 6 cm |
| 2 - 5½": 14 cm | 6 - 2": 5 cm |
| 2a - 4½": 11½ cm | 6a 1½": 38 mm |



- 9c ANGLE GIRDERS**
- | | |
|------------------|------------------|
| 7 - 24½": 62 cm | 9a - 4½": 11½ cm |
| 7a - 18½": 47 cm | 9b - 3½": 9 cm |
| 8 - 12½": 32 cm | 9c - 3": 7½ cm |
| 8a - 9½": 24 cm | 9d - 2½": 6 cm |
| 8b - 7½": 19 cm | 9e - 2": 5 cm |
| 9 - 5½": 14 cm | 9f - 1½": 38 mm |



FISHPLATE
10



DOUBLE BRACKET
11 - ½" x ½": 12 x 12 mm

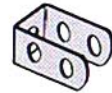

DOUBLE BRACKET
11a - 1" x ½": 25 x 12 mm



ANGLE BRACKETS
12 - ½" x ½": 12 x 12 mm
12a - 1" x 1": 25 x 25 mm
12b - 1" x ½": 25 x 12 mm



ANGLE BRACKET (OBTUSE)
12c - ½" x ½": 12 x 12 mm



- AXLE RODS**
- | | |
|-------------------|------------------|
| 13 - 11½": 29 cm | 16 - 3½": 9 cm |
| 13a - 8": 20 cm | 16a - 2½": 6 cm |
| 14 - 6½": 16½ cm | 16b - 3": 7½ cm |
| 14a - 5½": 14 cm | 17 - 2": 5 cm |
| 15 - 5": 13 cm | 18a - 1½": 38 mm |
| 15a - 4½": 11½ cm | 18b - 1": 25 mm |
| 15b - 4": 10 cm | |



SPOKED WHEEL
19a - 3": 75 mm



PULLEYS
19b - 3": 75 mm
20a - 2": 5 cm



PULLEY
- 6": 15 cm

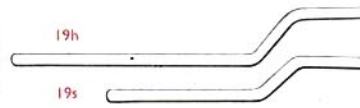

CRANK HANDLE
19h - 5": 13 cm
19s - 3½": 9 cm



FLANGED WHEELS
20 - 1¼": 28 mm
20b - ¾": 19 mm



PULLEY
21 - 1½": 38 mm



PULLEY
22 - 1": 25 mm



PULLEYS
22a - 1": 25 mm
23 plastic - ½": 12 mm
23a metal - ½": 12 mm



BUSH WHEEL
24 - 1¼": 34 mm

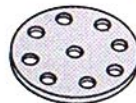

WHEEL DISC
24a - 1¼": 34 mm



BUSH WHEEL
24b - 1¼": 34 mm



WHEEL DISC
24c - 1¼": 34 mm



- PINIONS**
- | |
|---------------------------|
| 25 - 2" x ½": 19 x 6 mm |
| 25a - 2" x ½": 19 x 12 mm |
| 25b - 2" x ½": 19 x 19 mm |
| 26 - 1" x ½": 12 x 6 mm |
| 26a - 1" x ½": 12 x 12 mm |
| 26b - 1" x ½": 12 x 19 mm |
| 26c - 1" x ½": 11 x 6 mm |



GEAR WHEELS
27 - 1½": 32 mm
27a - 1½": 38 mm
27d - 1½": 41 mm



GEAR WHEELS
27b - 3½": 9 cm
27c - 2½": 6 cm



GEAR WHEELS
27c



MULTI-PURPOSE GEAR WHEEL
27f



CONTRATE WHEEL
28 - 1½": 38 mm
29 - ¾": 19 mm



BEVEL GEAR
For use in pairs.
30 - ¾": 22 mm



BEVEL GEARS
can only be used together.
30a - ¾": 12 mm
30c - 1¼": 38 mm



GEAR WHEEL
31 - 1" x 1"
25mm x 6mm



WORM
32 - ½": 12 mm



SPANNER
34c
BOX SPANNER
34b



SPRING CLIP
35



SCREWDRIVERS
36

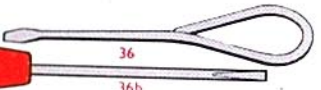

DRIFT
36c

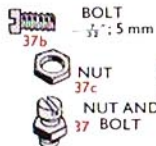

BOLT
37b - ½": 5 mm
NUT
37c
NUT AND BOLT
37



WASHERS
38 - ½": 10 mm
38d - ¾": 19 mm



HANK OF CORD
40



PROPELLER BLADE
41



TENSION SPRING
43 - 2": 5 cm



BENT STRIP STEPPED
44



DOUBLE BENT STRIP
45



DOUBLE ANGLE STRIPS
46 - 2½" x 1": 60 x 25 mm
47 - 2½" x 1½": 60 x 38 mm
47a - 3" x 1½": 75 x 38 mm
48 - 1½" x ½": 38 x 12 mm
48a - 2½" x ½": 60 x 12 mm
48b - 3½" x ½": 90 x 12 mm
48c - 4½" x ½": 115 x 12 mm
48d - 5½" x ½": 140 x 12 mm



SLIDE PIECE
50

How to use this Book

We ask you to do us a special favour by reading carefully everything on this page, and pages 2, 3 and 4 of the cover before starting to build your first model.

We know you will be anxious to build the biggest and most attractive models right away, but that is the worst mistake you can make. Please take our advice and start with one of the more simple models. You will find one of these very easy to put together and then you can go on to the more elaborate models.

Get to know your Meccano

On opening your set study the various parts carefully. Then turn to pages 2, 3 and 4 of the cover of this book. There you will find illustrations of the parts, together with their part numbers.

The parts used in the assembly of models shown in this Book usually can be identified simply by looking at the illustrations, but where the identity of a part may not be quite clear, its part number is printed in the model illustrations in Red.

To help you further, each model is accompanied by a list of all the parts required to build it. In this list, the catalogue numbers of the parts are printed in Red and the quantity of each part in Black.

Some simple assemblies of parts are used time and time again in all kinds of models. These are called *Basic Meccano Constructions* and some of them are shown on pages 4, 5, 6 and 7 of the combined No. 2/3/4 book. Each of these assemblies has been given a special identity code mark, such as BC1, BC2, etc. When any of these methods of construction are used in a model they are indicated in the drawings by their code mark. For example, when you see BC1 in an illustration you will know that the construction of that section of the model is similar to BC1 shown in the combined No. 2/3/4 book.

Some models are most easily illustrated and constructed in separate units. The points at which these units are bolted together to form the complete model are indicated in the drawings by red dots. In cases where red indicating lines pass behind Plates or other parts of a model, they are shown dotted.

Some of the models in this Book are fitted with a Meccano Motor. In these models the particular type of Motor used is indicated on the drawings by one of the following code marks: M1 = Meccano Magic Motor; M2 = Meccano No. 1 Clockwork Motor; M3 = Meccano E15R Electric Motor; M4 = Meccano Junior Power Drive Unit; M5 = Meccano Power Drive Unit.

Please note that Motors are only included in 3M, 4M and 5ME Sets, but are also obtainable separately from your Meccano dealer.

Het gebruik van dit boek

Lees zorgvuldig alles wat op deze pagina en op Pagina's 2, 3 en 4 van de omslag staat.

Natuurlijk wil je nu direct grote, modellen gaan bouwen, maar dat is de grootste fout die je kunt begaan. Volg onze raad op en begin met de eenvoudigere modellen. Je zult merken dat deze gemakkelijk in elkaar te zetten zijn en dan kun je overgaan tot het bouwen van een ingewikkelder model.

Leer je Meccano kennen

Als je je Meccano doos hebt opengemaakt, bekijk goed de onderdelen die je aantreft. Op pagina's 2, 3 en 4 van de omslag zie je genummerde afbeeldingen van onderdelen.

De onderdelen gebruikt bij het bouwen van voorbeelden in dit boek, kunnen herkend worden op de afbeelding van het model. Waar het herkennen van een onderdeel moeilijkheden geeft, is het nummer van dat onderdeel in rood in de afbeelding gedrukt.

Om je verder nog te helpen, staat er bij ieder model nog een lijst van onderdelen die nodig zijn om dit model te bouwen. In deze lijst zijn de nummers van de onderdelen rood gedrukt en de aantallen die je ervan nodig hebt in zwart.

Sommige, eenvoudige onderdelen-constructies worden geregeld in verschillende modellen gebruikt. Deze constructies worden *Meccano-basis-constructies* genoemd. Enige hiervan zijn afgebeeld op pagina's 4, 5 en 6 in boek nr. 2/3/4. Elk van deze constructies heeft een speciaal code-nummer zoals BC1, BC2, enz. Wanneer deze constructies worden gebruikt in een model, dan worden zij in de afbeelding aangegeven door hun code-nummer. B.v.: zie je BC1 in een afbeelding, dan weet je dus dat de constructie van dat deel van het model overeenkomstig is aan de basis-constructie BC1 zoals die afgebeeld en beschreven staat in boek nr. 2/3/4.

Verscheidene modellen zijn op eenvoudige wijze afgebeeld en in afzonderlijke delen geconstrueerd. Waar deze onderdelen aan elkaar bevestigd moeten worden teneinde het complete model te vormen, zijn deze in de afbeeldingen met rode punten aangegeven.

Enige modellen in dit boek zijn uitgerust met een Meccano motor. In deze modellen is het type motor dat gebruikt is in de afbeelding aangegeven met een van de volgende code-nummers: M1 = Meccano tover-motor; M2 = Meccano veerwerk motor no. 1; M3 = Meccano elektro motor E15R; M4 = Meccano Junior aandrijfmotor M5 = Meccano Junior aandrijfset

Attentie: de Meccano motoren zijn alleen bij uitrustingen 3M, 4M en 5ME inbegrepen, maar zijn echter afzonderlijk bij je Meccano dealer verkrijgbaar.

Comment vous servir de ce livre

Voulez-vous nous faire plaisir? Oui? Alors, avant de toucher aux pièces de votre Meccano, lisez attentivement cette page et les pages 2, 3 et 4 de la couverture.

Eiffel n'a pas construit sa tour à 14 ans! Vous non plus, ne commencez pas par le modèle le plus compliqué de ce livre. Vous risqueriez de ne pas le réussir et vous seriez déçu. Croyez nous (nous avons fait du Meccano avant vous!): commencez par le plus simple. Il vous semblera facile et ensuite vous n'aurez qu'à continuer.

Apprenez à connaître les pièces

Regardez bien les pièces de votre boîte. Vous les retrouverez illustrées sur les pages 2, 3 et 4 de la couverture de ce livre, avec leurs numéros.

Sur les illustrations qui vous aideront à construire un modèle, vous les reconnaîtrez rapidement. En plus, pour vous aider, les numéros des pièces sont imprimés en rouge. Chaque modèle est accompagné de la liste des pièces nécessaires pour le construire. Les numéros des pièces sont en rouge, les quantités en noir.

Il y a des montages qui reviennent dans chaque modèle. Nous les appelons "Montages de base" et vous en trouverez quelques uns sur les pages 4, 5, 6 et 7 du livre No. 2/3/4. Ils portent les deux lettres BC et un numéro. Quand vous verrez BC1, par exemple, dans un modèle, vous saurez que la construction de cette partie du modèle est semblable à celle du montage BC1 illustré dans le livre No. 2/3/4

Pour plus de facilité, certains modèles sont construits et illustrés en éléments séparés. Les différents endroits où ces parties doivent être réunies et boulonnées pour former le modèle complet sont indiqués par des points rouges.

Parfois les modèles sont animés par un moteur. Sur les illustrations M1 désigne le moteur mécanique Magic, M2 le moteur mécanique 1, M3 le moteur électrique E15R, M4 = le moteur Meccano Junior; M5 = l'ensemble Meccano de commande à moteur.

Seules les boîtes 3M, 4M et 5ME disposent d'un moteur mais tous les types de moteurs peuvent être achetés séparément.

Come Adoperare Questo Libro

Ci farete un grato favore se prima di applicarvi alle costruzioni Meccano leggerete attentamente quanto vi suggeriamo qui appresso e sulle pagine 2, 3, e 4

Certo vi piacerebbe costruire subito qualche modello grande e attraente ma non è così che si deve incominciare. Vi consigliamo invece di iniziare il gioco costruendo alcuni modelli semplici per acquistare pratica e riuscire poi meglio nelle costruzioni maggiori.

E' bene conoscere a fondo il proprio Meccano

Apriamo la vostra Scatola per la prima volta rendetevi conto dei pezzi che contiene. Sulle pagine 2, 3 e 4 della copertina di questo libro troverete le corrispondenti illustrazioni con i rispettivi numeri. I pezzi usati per costruire i modelli illustrati in questo libro si identificano osservando le relative figure. Nei casi in cui qualche pezzo non possa essere facilmente individuato, il suo numero è segnato in rosso nella illustrazione del modello. Per ciascun modello è indicata una lista dei pezzi occorrenti per la costruzione; i numeri in rosso sono quelli che identificano i pezzi mentre i numeri in nero sono quelli della quantità necessaria.

Certi accoppiamenti di pezzi sono comuni in molti modelli e sono denominati "Costruzioni di Base Meccano", come da illustrazioni pagine 4, 5, 6, e 7 di libro No. 2/3/4. Queste combinazioni di pezzi Meccano hanno ognuna una sigla di riferimento, come: BC1, BC2 ecc. e quando devono essere usate costruire modelli sono indicate nelle illustrazioni con la loro sigla. Per esempio quando in una figura è segnato BC1 vuol dire che per costruire quella parte del modello occorre la combinazione di pezzi BC1 illustrata nel libro No. 2/3/4

Alcuni modelli sono più facili da costruire a sezioni separate, come da illustrazioni. I punti di congiunzione delle varie sezioni per montare il modello sono indicati in rosso sulla figura.

Nelle illustrazioni di alcuni modelli è compreso un Motorino e viene indicato con sigla abbreviata come segue: M1 = Motorino a Molla Meccano Magic; M2 = Motorino a Molla Meccano No.1; M3 = Motorino Elettrico Meccano E15R; M4 = Motorino elettrico Meccano 'Junior'; M5 = Motorino elettrico Meccano con cambio a sei velocità.

Tenere presente che i motorini Meccano sono compresi soltanto nelle Scatole 3M, 4M e 5ME.

Die Benutzung dieses Heftes

Wir bitten Sie, diese ganze Seite und Seiten 2, 3 und 4 vom Deckel genau durchzulesen, bevor Sie mit dem Bau Ihres ersten Modells beginnen. Sie tun uns damit einen besonderen Gefallen.

Wir können uns denken, dass Sie am liebsten gleich das grösste und interessanteste Modell bauen wollen; aber das wäre der schlimmste Fehler, den Sie machen können. Halten Sie sich bitte an unseren Rat und beginnen Sie mit einem der einfacheren Modelle. Sie werden sehen, dass sich diese sehr leicht zusammensetzen lassen. Und dann können Sie zu den schwierigeren übergehen.

Schauen Sie sich in Ihrem Meccano um!

Betrachten Sie die Teile Ihres Baukastens genau. Dann schauen Sie auf Seiten 2, 3 und 4 vom Deckel dieses Heftes. Dort finden Sie Abbildungen der Teile mit ihren Nummern.

Die Teile, die zum Zusammenbau der in diesem Heft gezeigten Modelle gebraucht werden, kann man gewöhnlich leicht in den Abbildungen erkennen. In Fällen, wo dies unklar ist, ist die Nummer des Teils rot in die Abbildung gedruckt.

Eine weitere Hilfe für Sie ist, dass wir neben jedem Modell eine Aufstellung der dazu nötigen Teile bringen. In dieser Aufstellung sind die Katalognummern der Teile rot, die Anzahl eines jeden Teils schwarz gedruckt.

Einige einfache Zusammensetzungen von Teilen kommen in jeder Art von Modellen immer wieder vor. Sie werden "Meccano-Grundkonstruktionen" genannt. Einige davon sind auf Seiten 4, 5, 6 und 7 des Heftes Nr. 2/3/4 abgebildet. Jede dieser Zusammenstellungen hat zur Bezeichnung eine besondere Abkürzung, wie zum Beispiel BC1, BC2, usw. Kommt diese Zusammenstellung in einem Modell vor, so wird in den Abbildungen durch ihre Abkürzung darauf hingewiesen. Wenn Sie zum Beispiel auf einer Abbildung BC1 angegeben sehen, so wissen Sie, dass die Bauweise dieses Modellteils dieselbe ist, wie bei BC1 im Hefte Nr. 2/3/4.

Einige Modelle sind zur Vereinfachung in getrennten Abschnitten aufgebaut und abgebildet. Die Stellen, an denen diese Bauteile zum vollständigen Modell zusammengeschraubt werden, sind in den Abbildungen durch rote Punkte bezeichnet. Wo rote Markierungslinien hinter Platten oder anderen Modellteilen verlaufen, sind sie punktiert gezeichnet.

Einige der Modelle in diesem Heft sind mit einem Meccano-Motor ausgestattet. Bei diesen Modellen ist die jeweilige Motorart auf den Abbildungen durch eine der folgenden Abkürzungen vermerkt: M1 = Meccano Zaubermotor; M2 = Meccano Federmotor Nr. 1; M3 = Meccano Elektromotor. E15R; M4 = Meccano Junior Antriebsmotor; M5 = Meccano Antriebsmotor.

Beachten Sie bitte, dass diese Motoren nur in den Baukästen Nr. 3M, 4M und 5ME enthalten sind. Sie können sie aber bei ihrem Meccano Händler als Zubehör erhalten.

Hur man använder denna bok

Vi ber Dig göra oss en tjänst genom att noga läsa igenom allting på denna sida samt sidorna 2, 3 och 4 av omslaget innan Du börjar bygga Din första modell.

Vi vet att Du är ivrig med att genast vilja bygga de största och finaste modellerna, men det är det värsta misstag Du kan göra. Följ i stället vårt råd och börja med en av de enklare modellerna. Du finner att dessa är mycket lätta att bygga och sedan kan Du fortsätta med allt större och svårare modeller.

Lär känna Ditt Meccano

När Du öppnar Din byglåda, studera då delarna noga. Vänd sedan till sidorna 2, 3 och 4 på omslaget av denna bok. Där finner Du delarna avbildade tillsammans med nummer.

Delarna som används för byggandet av modellerna i denna bok kan Du lätt känna igen genom att se på avbildningarna. Där Du inte säkert kan känna igen en viss del är numret tryckt i rött på illustrationen.

För att hjälpa Dig vidare åtföljes varje modell av en lista över alla delar, som behövs för att bygga den. I denna lista är katalognumren tryckta i rött och antalet av varje del som åtgår i svart.

Några enkla konstruktioner användes gång efter annan i alla slags modeller. Dessa kallas "Meccano grundkonstruktioner" och några av dem är avbildade på sidorna 4, 5, 6 och 7 i bok nr. 2/3/4. Var och en av dessa konstruktioner har ett speciellt kodnummer så som BC1, BC2 o.s.v. När dessa byggmetoder användes till en modell, är kodnumren utsatta i ritningarna. När Du t.ex. ser BC1 i en avbildning skall Du veta, att denna sektion bygges som BC1 visar i bok nr. 2/3/4.

Några modeller är mycket lätta att konstruera, särskilt som de är avbildade i två eller flera enheter. De ställen, vid vilka dessa enheter sedan sättes samman för att bilda den färdiga modellen, angivas på ritningarna med röda punkter. I de fall då röda hänvisningslinjer passerar bakom plåtar eller andra delar i en modell, är dessa linjer ej heldragna.

Några av modellerna i denna bok är försedda med en Meccano-motor. På dessa modeller är den speciella motorn angiven i ritningarna med ett av de följande kodnumren: M1 = Meccano fjädermotor Magic; M2 = Meccano fjädermotor nr 1; M3 = Meccano elektrisk motor E15R; M4 = Meccano Junior motor; M5 = Meccano drivaggregat.

Observera att motorerna ingår endast i byglådorna, 3M, 4M och 5ME, men kan erhållas separat av Din Meccano-handlare.

Modo de Empleo de este Libro

Antes de todo deseamos solicitar un favor, o sea; que leáis con gran atención toda esta página y las páginas 2, 3 y 4 de la cubierta, antes de empezar a construir vuestro primer modelo.

Desde luego, ya sabemos que teneis gran interes y anhelo de construir inmediatamente los modelos más grandes y más atractivos, sin embargo, eso sería un gran error. Por lo tanto, seguid nuestro consejo, el cual es de que empecéis con los modelos más sencillos y fáciles de construir. Estos modelos son los primeros pasos hacia la meta de vuestra aspiración, la cual es la de construir modelos grandes y elaborados.

Vamos a estudiar Meccanología

Primeramente se abre el Equipo y se examinan y estudian las piezas muy detenidamente. Luego se lee con atención las páginas 2, 3 y 4 de la cubierta de este libro, en el cual se hallen las piezas ilustradas junto con su respectivo número. Las piezas usadas en la construcción de los modelos que se ven en este libro pueden reconocerse seguida y sencillamente, si se estudian las ilustraciones. Ahora bien, en el caso de que una pieza no pueda reconocerse enseguida, se mira el número, el cual se ve en colorado en las ilustraciones de modelos.

Con el fin de ayudar a vuestra aspiración, cada modelo va acompañado de una lista de las piezas que se necesitan para su construcción. En esta lista el número de las piezas en el catálogo es colorado; la cantidad de piezas que se necesita va en número negro.

Algunos conjuntos sencillos de piezas se emplean una y más veces en toda clase de modelos. Estos se llaman "Construcciones Básicas Meccano", algunas de las cuales se ven en las páginas 4, 5, 6 y 7 del libro No. 2/3/4.

Cada uno de estos conjuntos tiene la marca de una clave especial, por ejemplo; BC1, BC2, etc. Cuando estos métodos de construcción se emplean en un modelo, pueden reconocerse en los grabados por sus respectivas marcas de clave. Esto es, cuando veáis BC1 en una ilustración, sabreis que la construcción de esa sección del modelo es igual que la BC1 vista en el libro No. 2/3/4.

Algunos modelos son muy fácilmente ilustrados y contruidos en unidades separadas. Las marcas coloradas en los dibujos denotan los puntos en los cuales estas unidades se empernan juntas para formar el modelo completo.

Cuando las líneas indicadoras rojas pasen por detrás de las planchas u otras piezas del modelo éstas se muestran por medio de puntos.

Algunos de los modelos en este libro tienen un Motor Meccano. El tipo de motor usado en estos modelos se indica en los grabados con una de las marcas de clave siguientes: M1 = Motor Meccano *Magic*; M2 = Motor a Resorte Meccano No. 1; M3 = Motor Eléctrico Meccano E15R. M4 = Unidad motriz Meccano Junior; M5 = Unidad de accionamiento Meccano.

Los motores se incluyen solamente en los equipos 3M, 4M y 5ME, pero pueden obtenerse en los comercios donde se venden los productos Meccano.

Modo de Utilizacao deste Livro

Antes de começar a construir o primeiro modelo pedimos o favor de ler cuidadosamente tudo aquilo que aqui se diz e nas paginas 2, 3 e 4 da capa. Sabemos que ficará ansioso por construir imediatamente os maiores e mais atraentes modelos, mas é o peor erro que pode cometer. Siga o nosso conselho e começa com um dos modelos mais simples, os quais verificará são de mais facil construção, e poderá continuar com os modelos mais complicados.

Aprenda a conhecer o seu Meccano

Ao abrir o estojo estude cuidadosamente todas as peças, e seguir olhe para as paginas 2, 3 e 4 da capa deste livrete, aí encontrará o desenho de todas as peças com numeros de referencia. As peças usadas na construção dos modelos ilustrados neste livrete podem ser identificadas simplesmente pelas ilustrações, mas quando a identificação duma peça não é clara o seu número é indicado a vermelho no desenho do modelo em questão.

Para maior auxilio, cada modelo é acompanhado por uma lista de todas as peças necessárias para a sua construção. Nesta lista os números do catalogo das peças são imprimidos a vermelho e as quantidades de cada peça a preto. Algumas montagens simples são usadas muitas vezes em todas as especies de modelos. Chamam-se estas "Construções básicas do Meccano" e algumas de las são ilustradas nas paginas 4, 5, 6 e 7 do livrete No. 2/3/4.

Cada uma destas construções basicas tem um código de identificação especial, tal como BC1, BC2, etc. Quando estas construções são usadas num modelo, são indicadas nos desenhos pelo código correspondente de identificação. Por exemplo, quando se vir BC1 num desenho sabe-se que a construção dessa parte de modelo é semelhante ao BC1 mostrado no livrete No. 2/3/4.

Alguns dos modelos são mais facilmente ilustrados e contruidos em unidades separadas. Os pontos nos quais estas unidades são colocadas e aparafusadas juntas para construir o modelo completo são indicados nos desenhos com pontos vermelhos.

Quando as linhas vermelhas indicadoras passam atrás de placas ou outras peças dum modelo, então são feitas a ponteado.

Alguns dos modelos neste livrete são montados com um motor Meccano. Nestes modelos o tipo de motor é indicado nos desenhos por um dos seguintes códigos de identificação:

M1 = Motor *Mágico* Meccano; M2 = Motor Meccano No. 1 com mecanismo de corda; M3 = Motor Electrico Meccano E15R; M4 = Unidade motriz Meccano Junior; M5 = Unidade motriz Meccano.

Agradecemos notar que os motores sómente são incluidos nos estojos 3M, 4M e 5ME, mas podem ser adquirido em separado em qualquer loja de vendas de Meccano.

Hvordan denne boken kan brukes

Vi ber deg å gjøre oss den tjenesten å lese nøye gjennom alt på denne siden og på sidene 2, 3 og 4 av omslag för du begynner å bygge din første modell.

De vil muligens gjerne starte med å bygge den største og fineste modellen med en gang, men dette vil vi råde dem fra. Det viser seg at man heller bör begynne med en av de enkle modellene, og heller öke vanskelighetsgraden etter hvert.

När du åpner settet, så studer delene omhyggelig. Vend så over til sidene 2, 3, og 4 i omslaget av boken. Der vil du finne bilder av delene sammen med delnummer.

Delene som brukes til å bygge modellene i denne boken, kan du sikkert lett kjenne igjen ved å se på avbildningene. Der du ikke kan kjenne igjen en viss del, er nummeret trykt på illustrasjonen i rött.

For å hjelpe deg videre, er hver modell fulgt av en liste over alle delene som trengs til å bygge den. I denne listen er katalognummeret trykt i rött og antallet som går med er trykt i sort.

Noen enkle konstruksjoner benyttes gang på gang i alle slags modeller. Disse blir kalt "Meccano grunnkonstruksjoner," og noen av dem er vist på sidene 4, 5, 6 og 7 i bok nr. 2/3/4. Hver av disse konstruksjoner har et spesielt kodenummer, som BC1, BC2 o.s.v. När disse byggetoder benyttes til en modell er kodenummerne trykt på tegningen. När du f.eks. ser BC1 i en illustrasjon, så vet du at konstruksjonen av denne delen av modellen er bygd som viser i bok nr. 2/3/4.

Noen modeller er konstruert i forskjellige enheter. De punkter som disse blir satt sammen i, for å danne den full stendige modellen, er vist med röde prikker. Der hvor röde linjer går bak plater eller andre deler på en modell, er de vist ved prikker.

Noen av modellene i denne boken er forsynt med Meccano Motor. På disse modellene er den spesielle motor angitt på tegningene med ett av de fölgende kodenummer: M1 = Meccano *Magic* Motor; M2 = Meccano nr. 1 urverk motor; M3 = Meccano elektrisk motor E15R; M4 = Meccano Junior motor M5 = Meccano Power Drive Unit.

Legg merke til at motoren bare følger med byggesettene 3M, 4M og 5ME, men kan kjøpes separat hos din Meccano-forhandler.

8.1 Camion-grue
Crane lorry
Kraanwagen
Camione-gru
Kranwagen
Camion-grua

8.1

6	-	1	1	-	18b	1	-	46	2	-	125
16	-	2	2	-	19b	2	-	48	2	-	126
6	-	3	1	-	19s	10	-	48a	4	-	126a
2	-	4	1	-	20a	1	-	48b	1	-	147b
14	-	5	4	-	20b	1	-	51	1	-	155
4	-	6a	5	-	22	2	-	52	2	-	176
6	-	8	2	-	22a	3	-	53	1	-	186
6	-	10	1	-	23	2	-	53a	4	-	187
4	-	11	1	-	23a	2	-	54	6	-	188
1	-	11a	2	-	24	1	-	57c	4	-	189
16	-	12	2	-	24c	6	-	59	1	-	190
4	-	12a	2	-	26	2	-	62	3	-	192
1	-	12c	1	-	27a	1	-	63	2	-	193a
1	-	14	11	-	35	2	-	90	1	-	193c
1	-	15	198	-	37a	8	-	90a	2	-	194
2	-	15a	181	-	37b	2	-	99	2	-	214
2	-	15b	26	-	38	2	-	111	4	-	221
2	-	16	2	-	38d	2	-	111a	2	-	222
1	-	17	2	-	40	4	-	111c	2	-	223
3	-	18a	2	-	45	2	-	115			

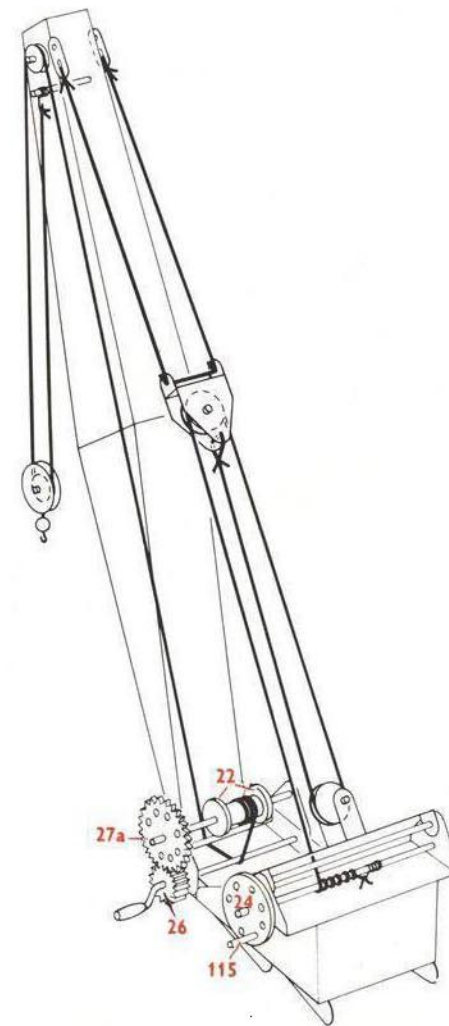
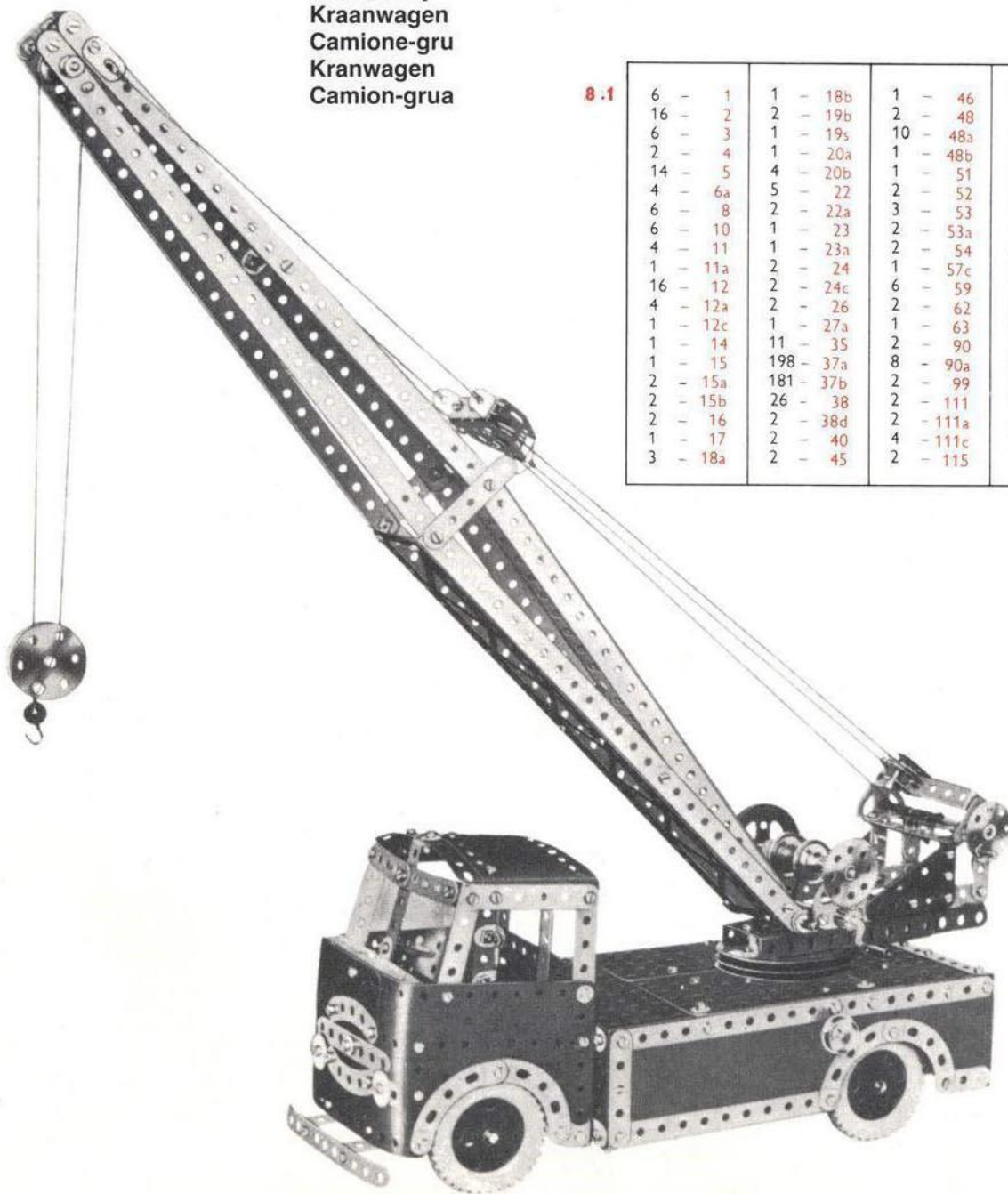

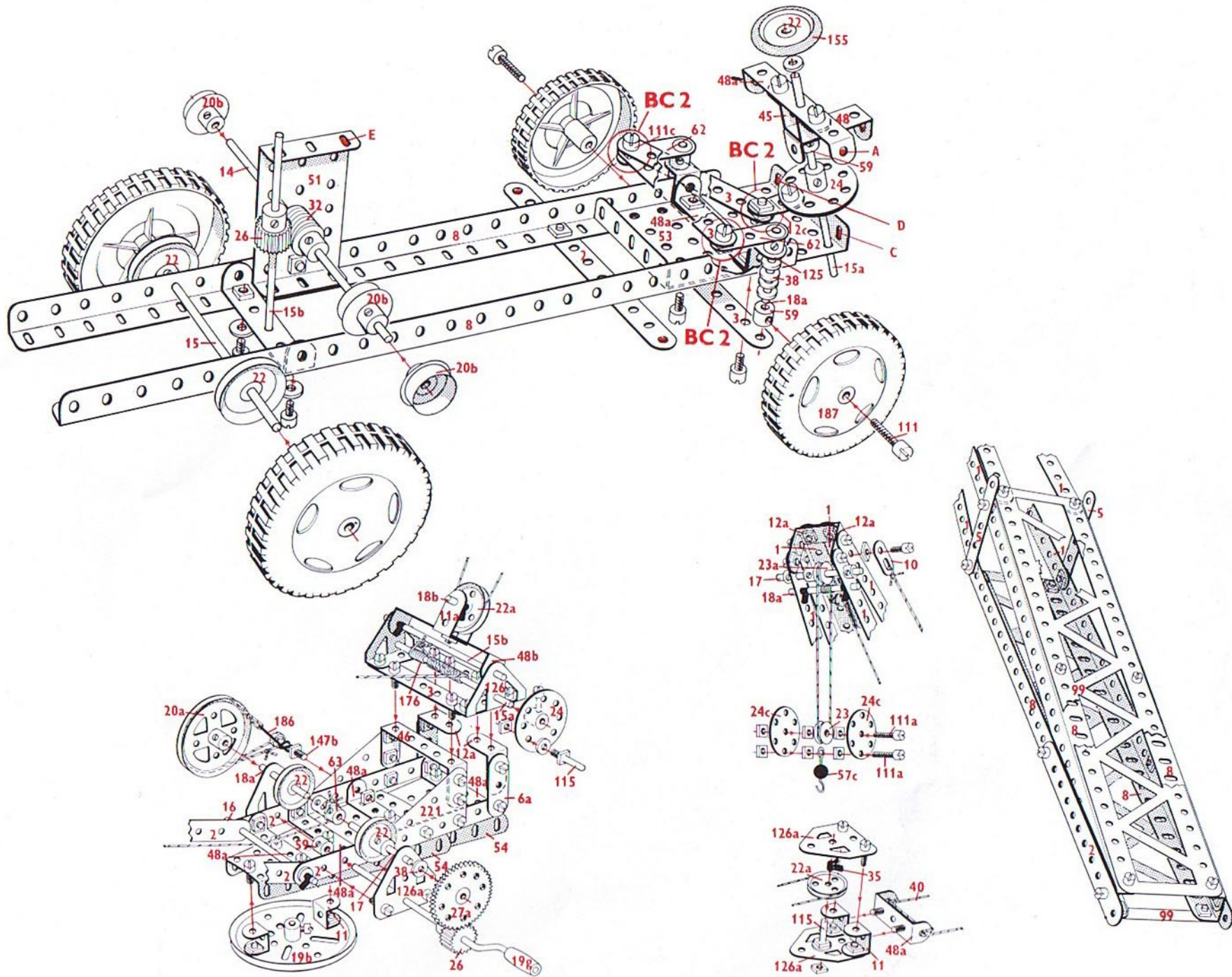

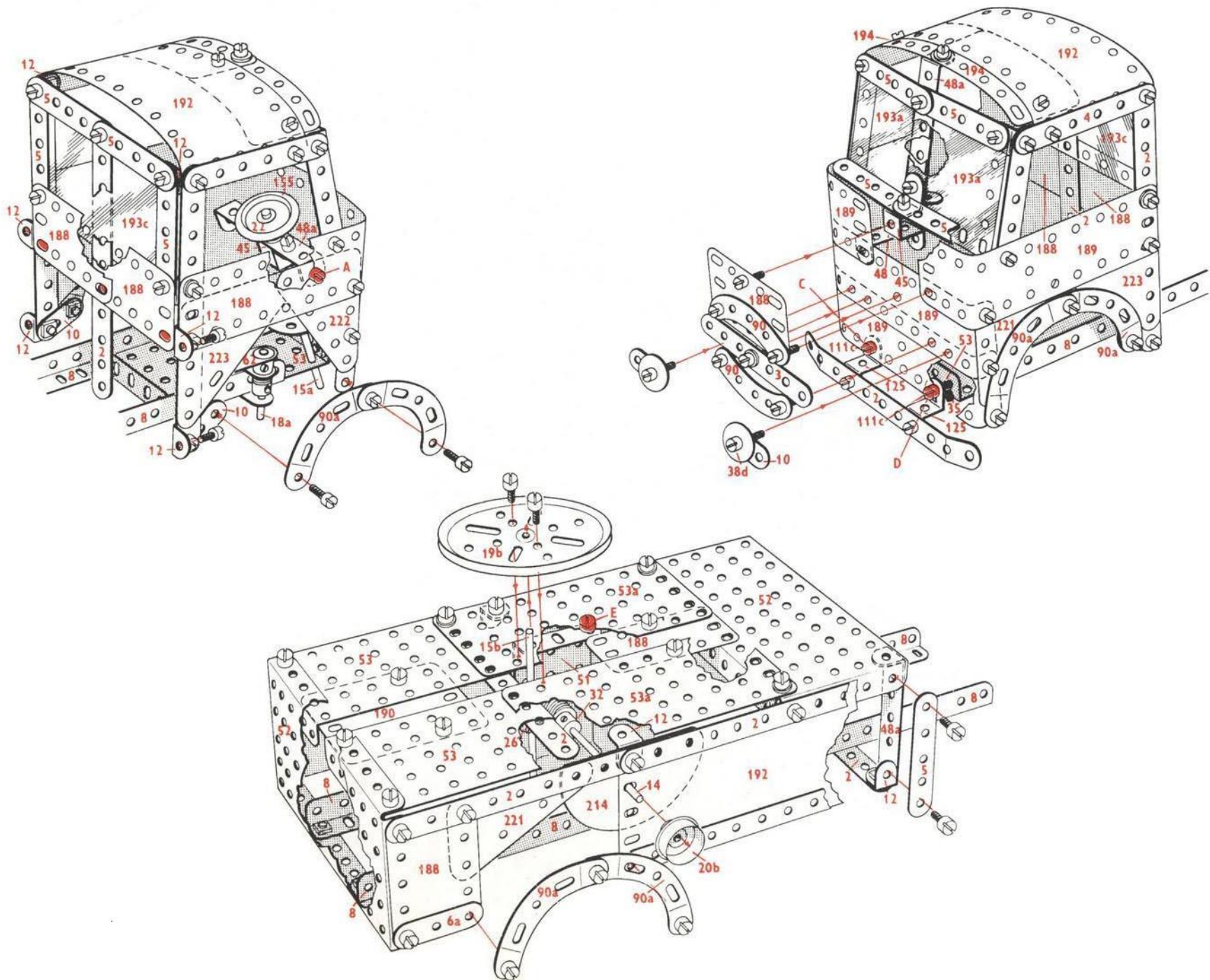

8.2 Grue de secours pour chemin de fer
 Railway safety lorry
 Noodkraan voor spoorwegen
 Gru di emergenza per ferrovia
 Notkran für eisenbahn
 Grúa de socorro para ferrocarril

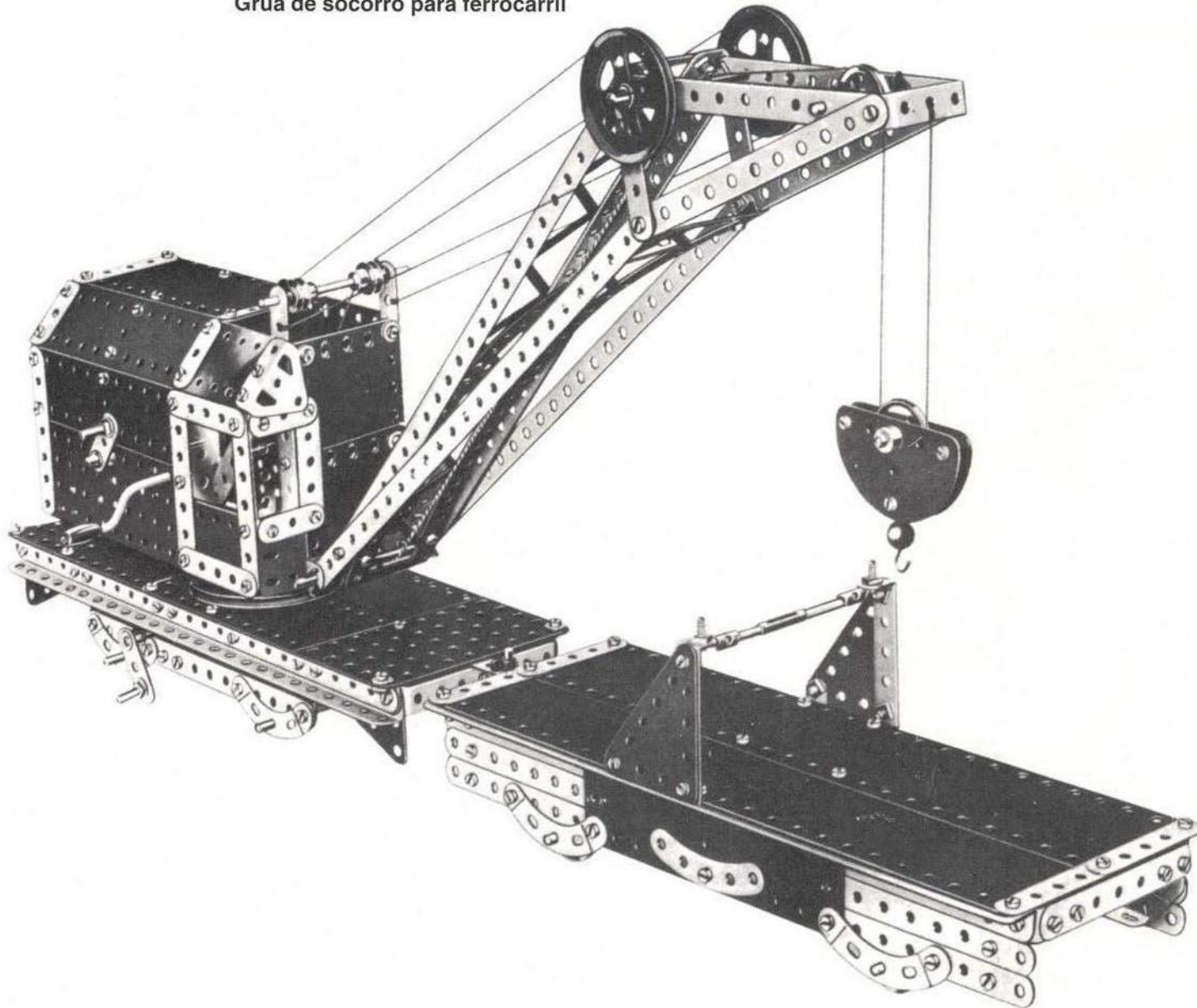

8.2

8	-	1	2	-	48
15	-	2	5	-	48a
6	-	3	2	-	48b
2	-	4	1	-	51
12	-	5	2	-	52
3	-	6a	3	-	53
8	-	8	2	-	53a
2	-	11	1	-	57c
1	-	11a	6	-	59
11	-	12	1	-	62
4	-	12a	1	-	63
7	-	12c	2	-	90
1	-	15	8	-	90a
3	-	15a	2	-	99
2	-	15b	2	-	111
4	-	16	2	-	111a
1	-	17	6	-	111c
3	-	18a	1	-	115
2	-	19b	4	-	125
1	-	19h	2	-	126
2	-	20a	1	-	147b
4	-	20b	2	-	176
5	-	22	1	-	186
2	-	22a	6	-	188
1	-	23	4	-	189
1	-	23a	2	-	190
1	-	24	2	-	191
2	-	24c	6	-	192
1	-	26	2	-	193
1	-	27a	1	-	193a
1	-	32	2	-	194
13	-	35	2	-	194d
198	-	37a	2	-	197
182	-	37b	2	-	212
26	-	38	1	-	213
2	-	38d	2	-	214
1	-	40	4	-	221
2	-	45	2	-	222

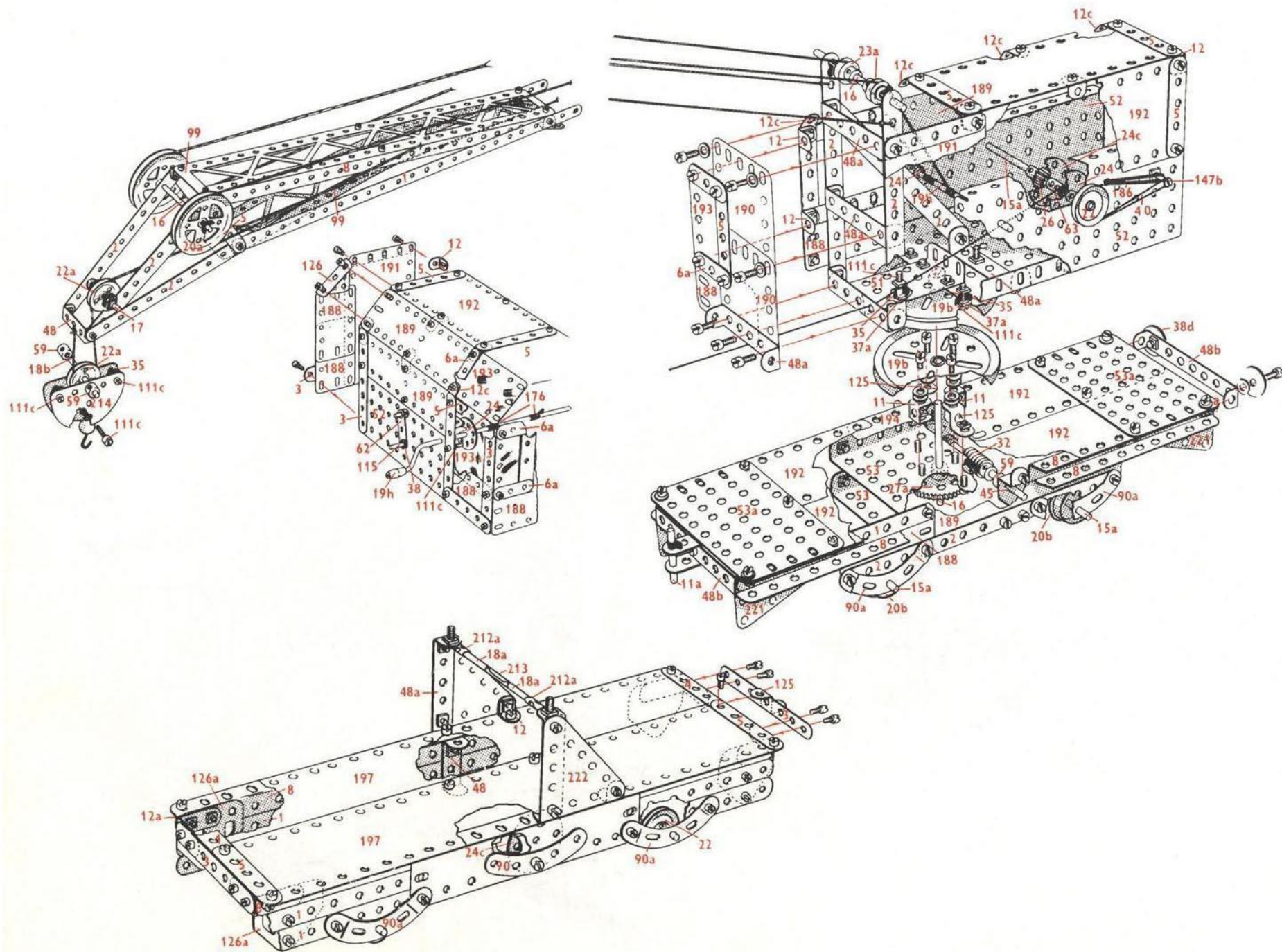

8.3 Portique de déchargement navires
 Ship unloading gantry
 Brugloskraan voor schepen
 Portico di scarico per navi **8.3**
 Portalausladekran für schiffe
 Pórtico de descarga para buques

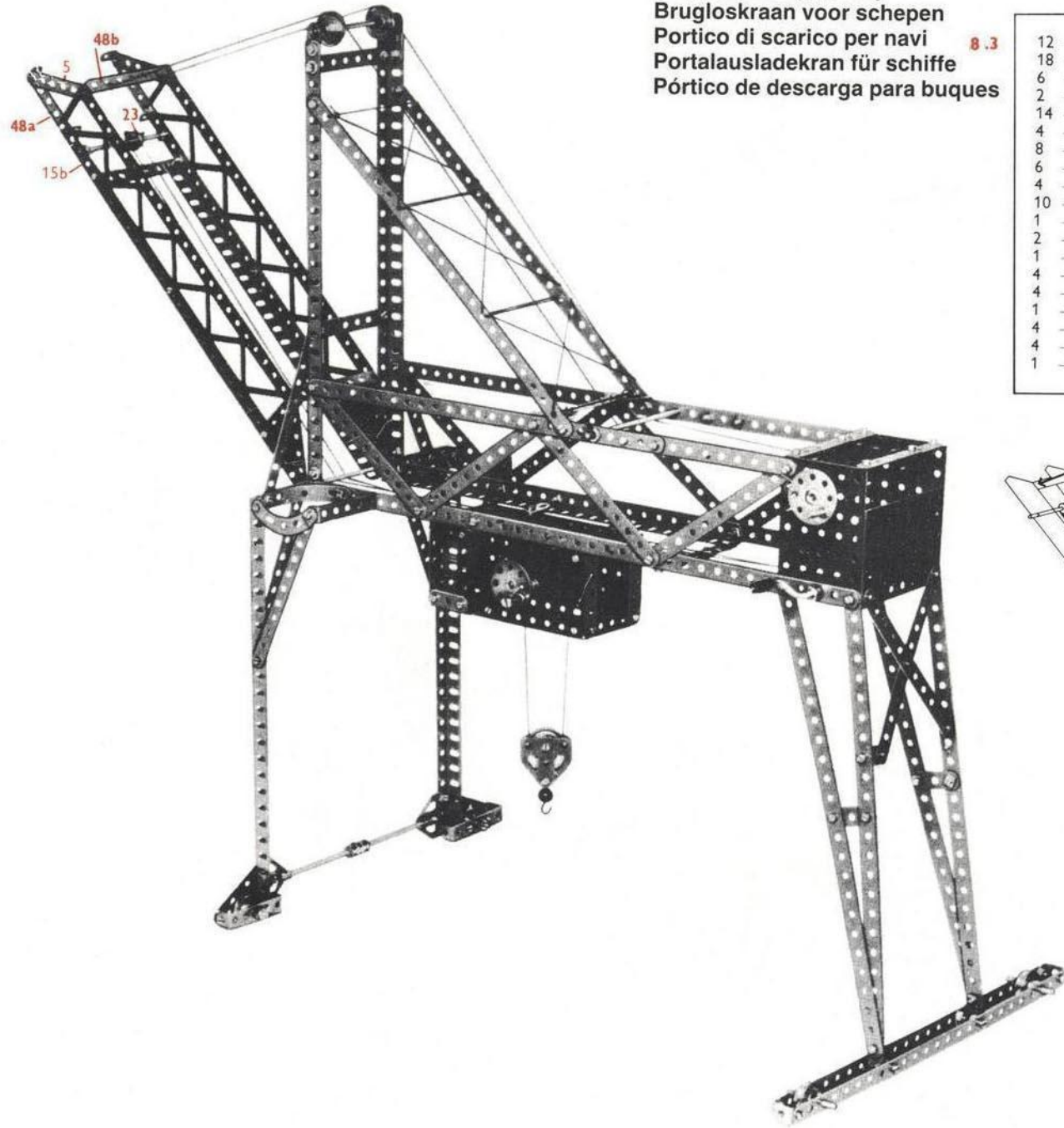

12	-	1	1	-	23	2	-	111
18	-	2	2	-	24	2	-	111a
6	-	3	8	-	35	5	-	111c
2	-	4	155	-	37a	2	-	126
14	-	5	142	-	37b	4	-	126a
4	-	6a	14	-	38	1	-	147b
8	-	8	2	-	40	2	-	176
6	-	10	9	-	48a	1	-	186
4	-	11	2	-	48b	1	-	188
10	-	12	1	-	51	2	-	190
1	-	15	1	-	52	2	-	193
2	-	15a	3	-	53	2	-	193a
1	-	15b	2	-	53a	2	-	212
4	-	16	1	-	57c	2	-	214
4	-	18a	6	-	59	2	-	215
1	-	19h	2	-	62	2	-	221
4	-	20b	1	-	63	2	-	222
4	-	22	2	-	90a			
1	-	22a	2	-	99			

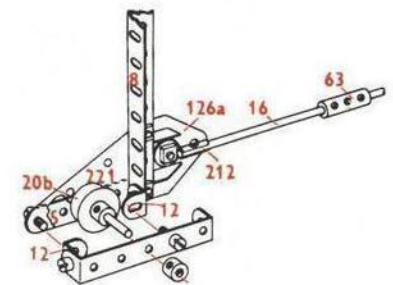
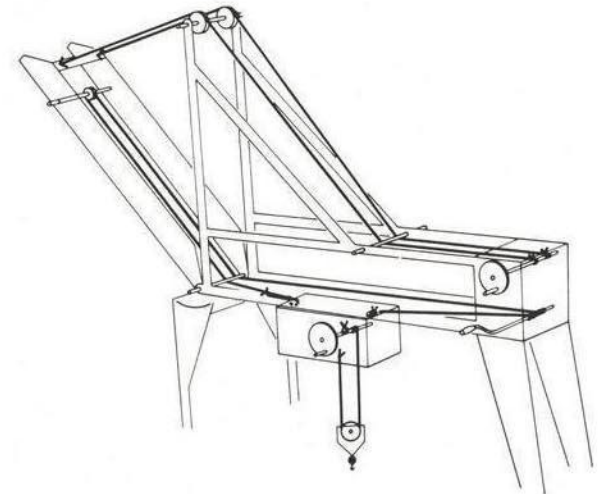

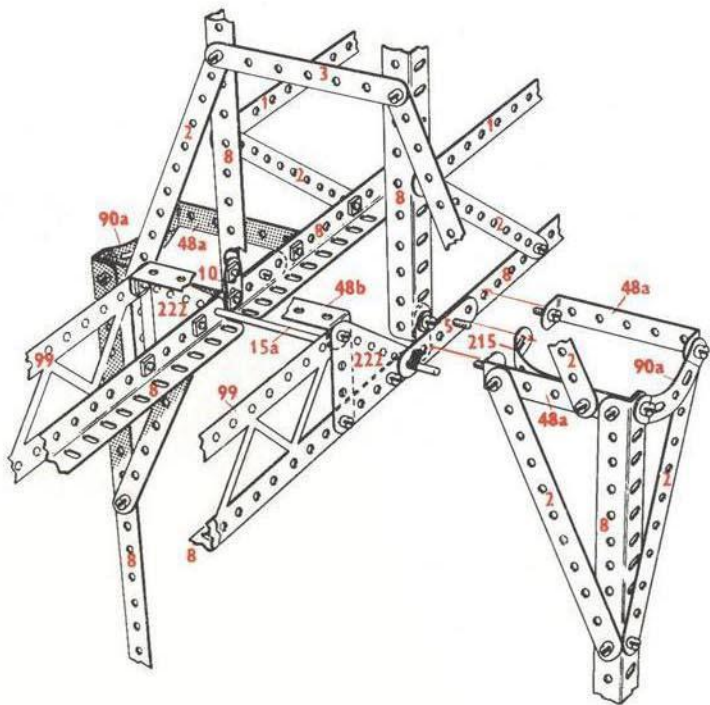
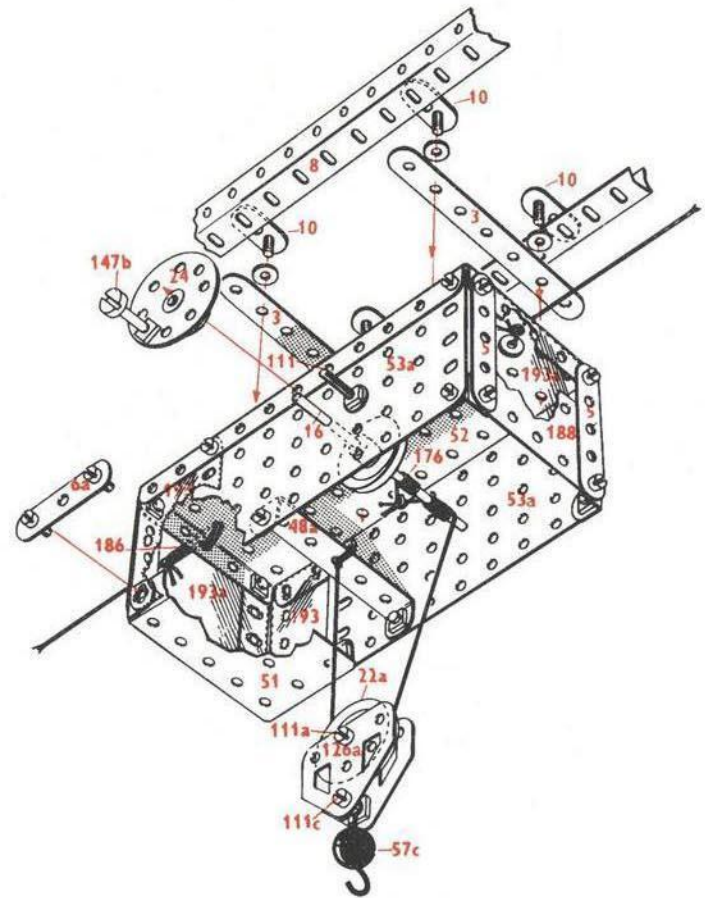
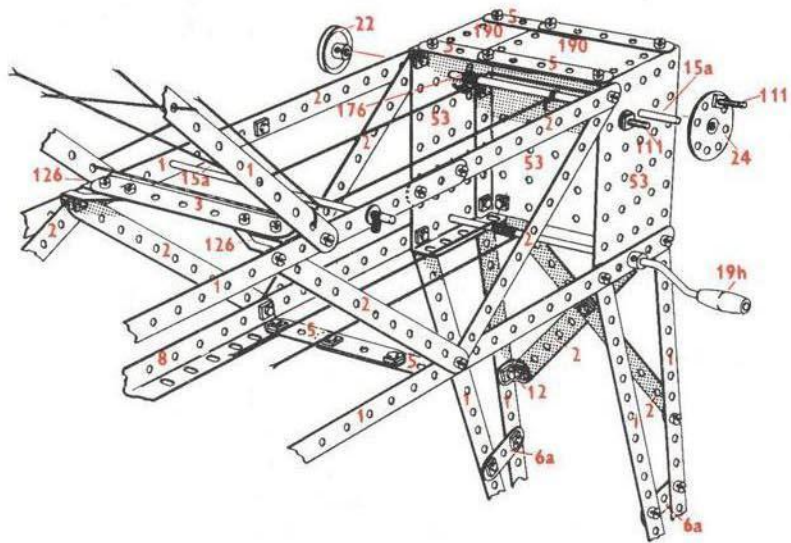

8.4 Grue mobile
 Mobile crane
 Mobiele kraan
 Gru mobile
 Beweglicher kran
 Grúa Móvil

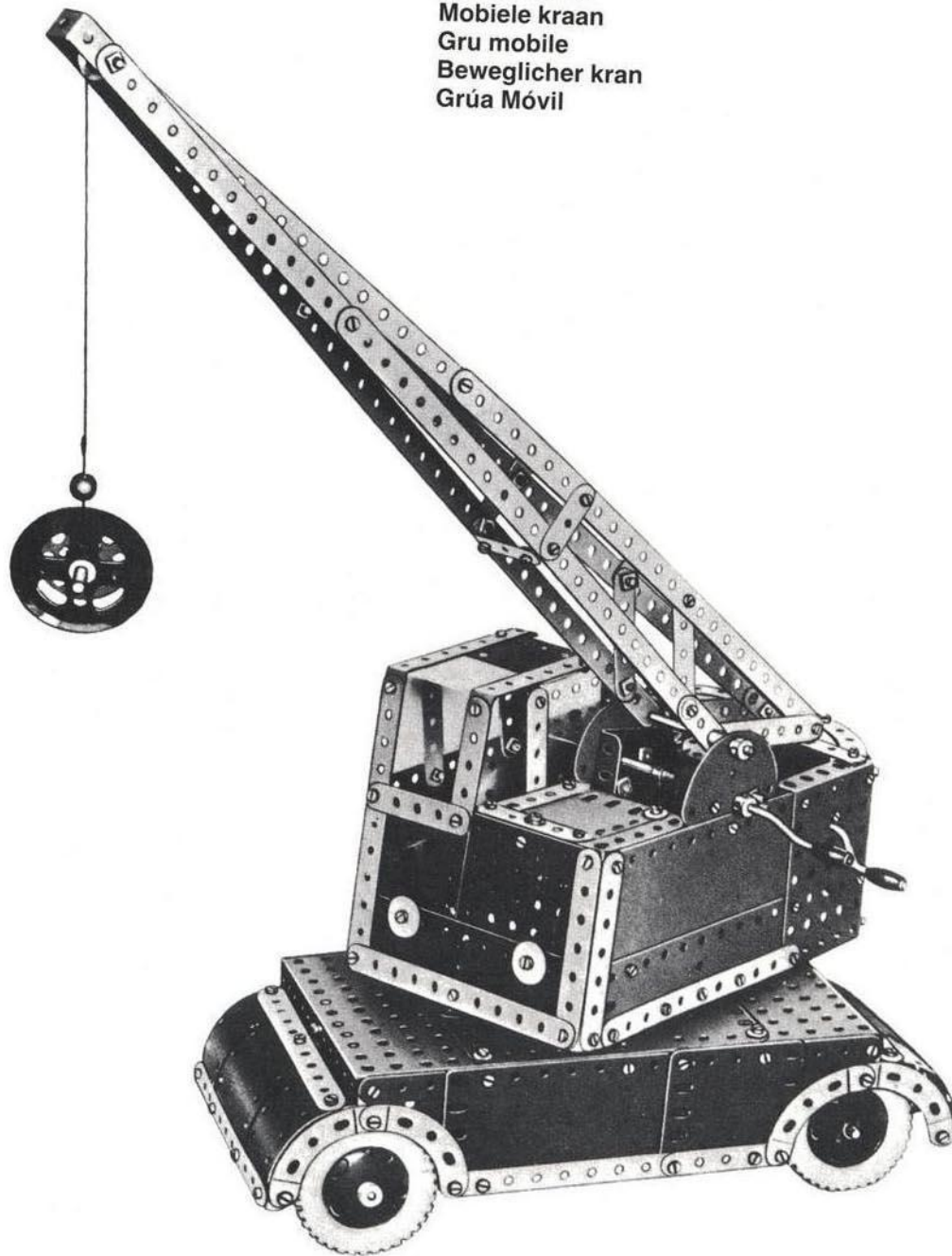

8.4

8	-	1	1	-	24	2	-111a
17	-	2	1	-	27a	4	-111c
6	-	3	1	-	32	1	- 115
2	-	4	4	-	35	2	- 125
14	-	5	186	-	37a	2	-126a
4	-	6a	173	-	37b	2	- 176
2	-	8	25	-	38	4	- 187
5	-	10	2	-	38d	6	- 188
4	-	11	1	-	40	3	- 189
1	-	11a	1	-	45	7	- 190
18	-	12	1	-	46	1	- 191
4	-	12a	2	-	48	5	- 192
4	-	12c	9	-	48a	2	- 193
1	-	14	1	-	51	2	-193a
1	-	15	2	-	52	1	-193c
1	-	15a	2	-	53	1	-193e
2	-	16	2	-	53a	1	- 194
2	-	18a	2	-	54	1	-194d
2	-	19b	1	-	57c	1	- 199
1	-	19s	5	-	59	1	- 200
1	-	19h	2	-	62	2	- 212
4	-	20b	1	-	63	2	- 214
2	-	22	2	-	90	3	- 215
1	-	23	8	-	90a	4	- 221
1	-	23a	2	-	111		

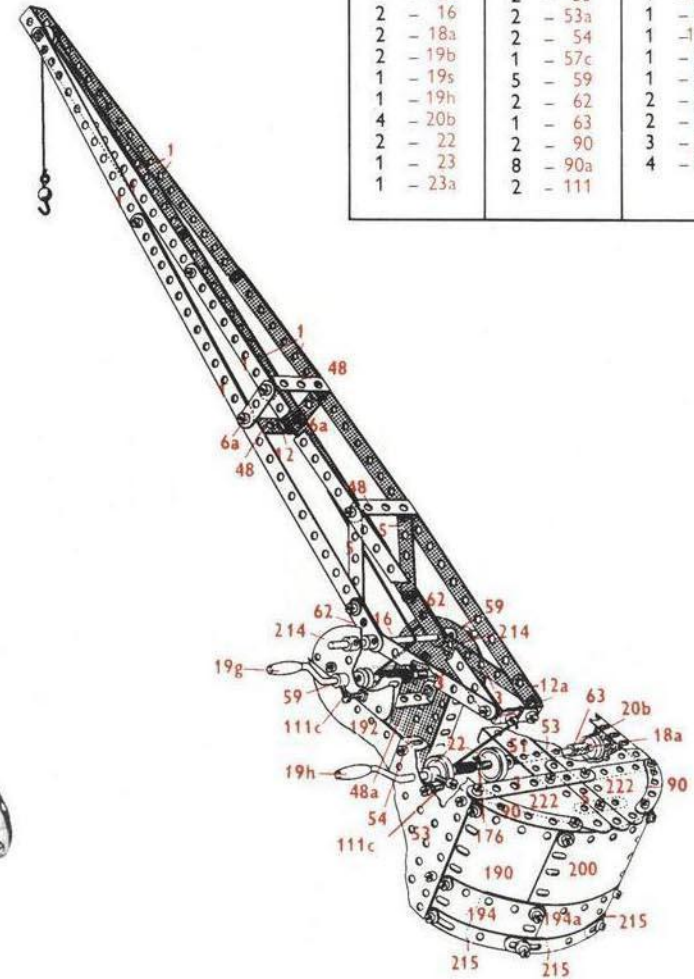

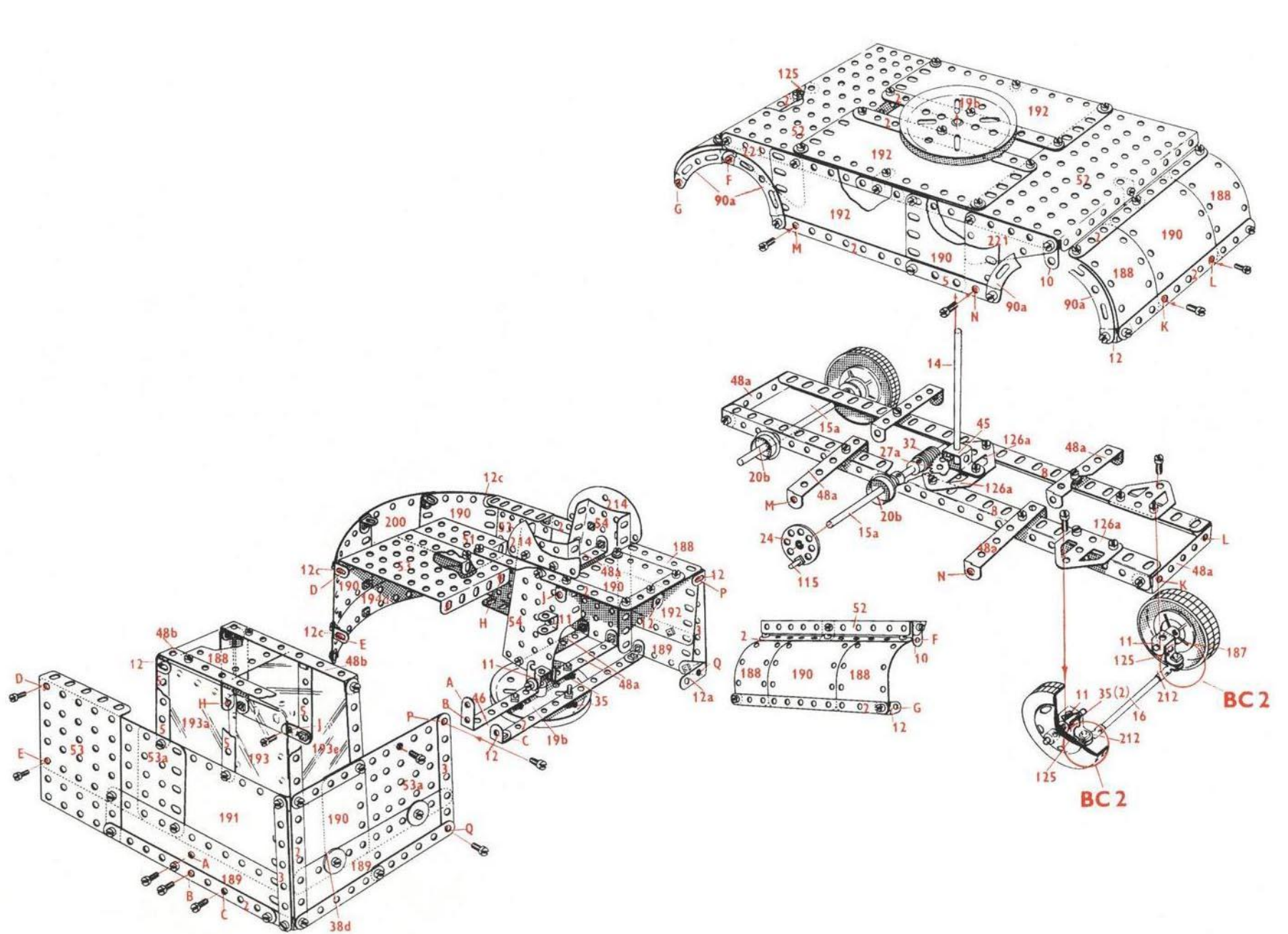

8.5

Camion à benne basculant latéralement
 Side dumper truck
 Vrachtwagen met zijkipbak
 Camione ribaltabile lateralmente
 Seitlicher kipwagen
 Camión basculador lateral

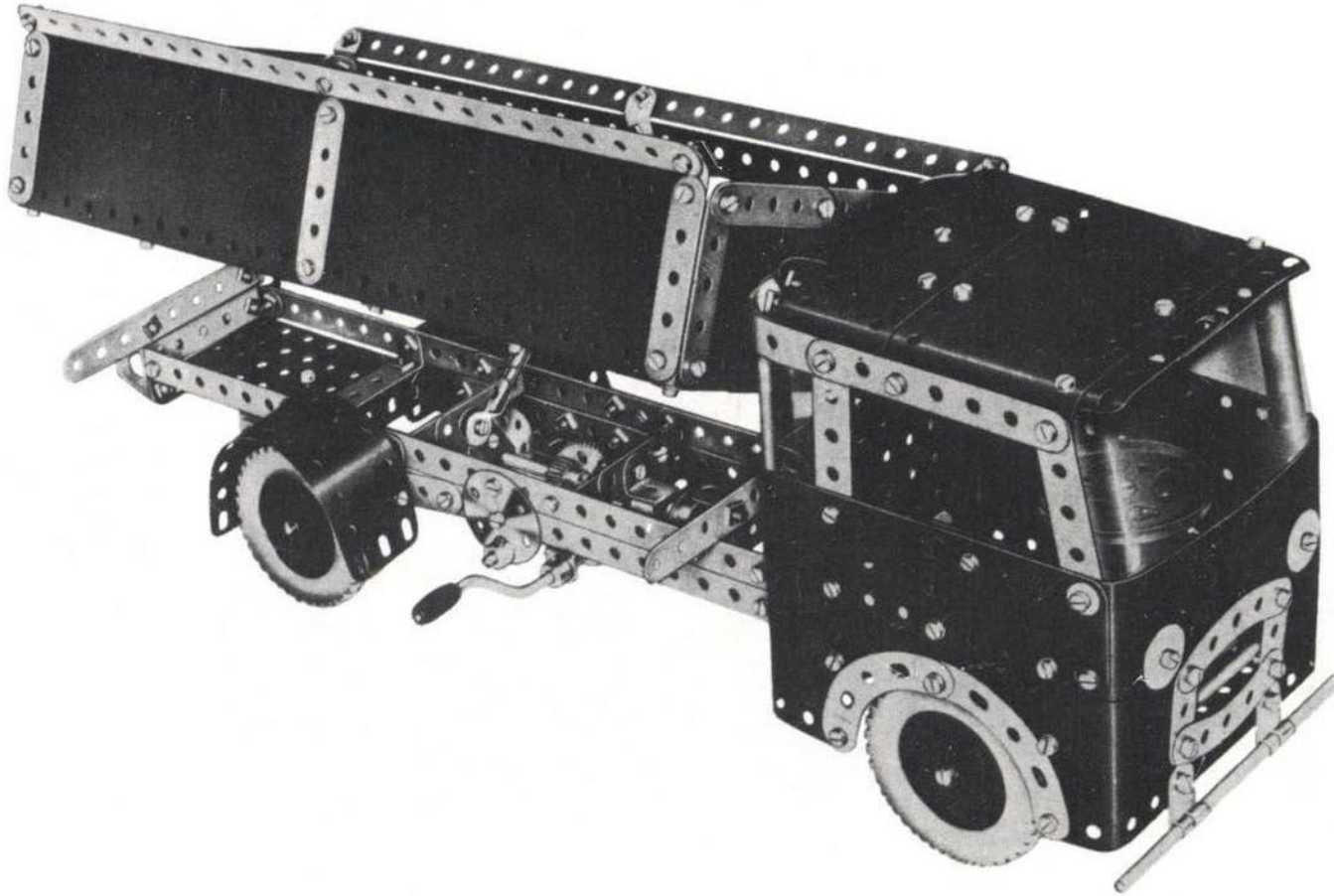
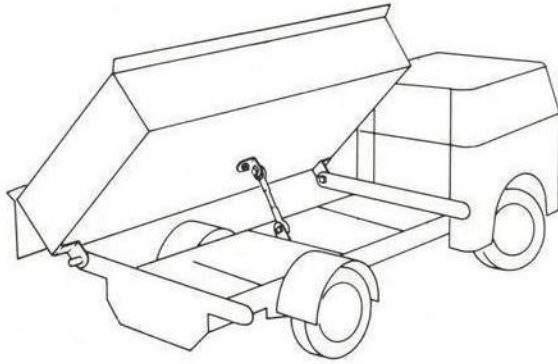

8.5

8	-	1	2	-	48
18	-	2	5	-	48a
6	-	3	1	-	48b
2	-	4	1	-	51
13	-	5	3	-	53
4	-	6a	2	-	53a
3	-	8	6	-	59
3	-	10	2	-	62
2	-	11	1	-	63
1	-	11a	2	-	90
17	-	12	4	-	90a
4	-	12a	2	-	111
6	-	12c	1	-	111a
2	-	15	4	-	111c
1	-	15a	2	-	115
1	-	15b	4	-	125
4	-	16	4	-	126a
2	-	18a	4	-	187
1	-	18b	2	-	188
1	-	19s	4	-	189
1	-	20a	8	-	190
3	-	20b	2	-	191
1	-	23a	6	-	192
2	-	24	2	-	193a
2	-	24c	1	-	193e
2	-	26	2	-	194a
1	-	27a	2	-	194d
1	-	32	2	-	197
6	-	35	1	-	199
193	-	37a	1	-	200
181	-	37b	2	-	212
15	-	38	2	-	212a
2	-	38d	2	-	214
1	-	45	2	-	215
1	-	46	4	-	221

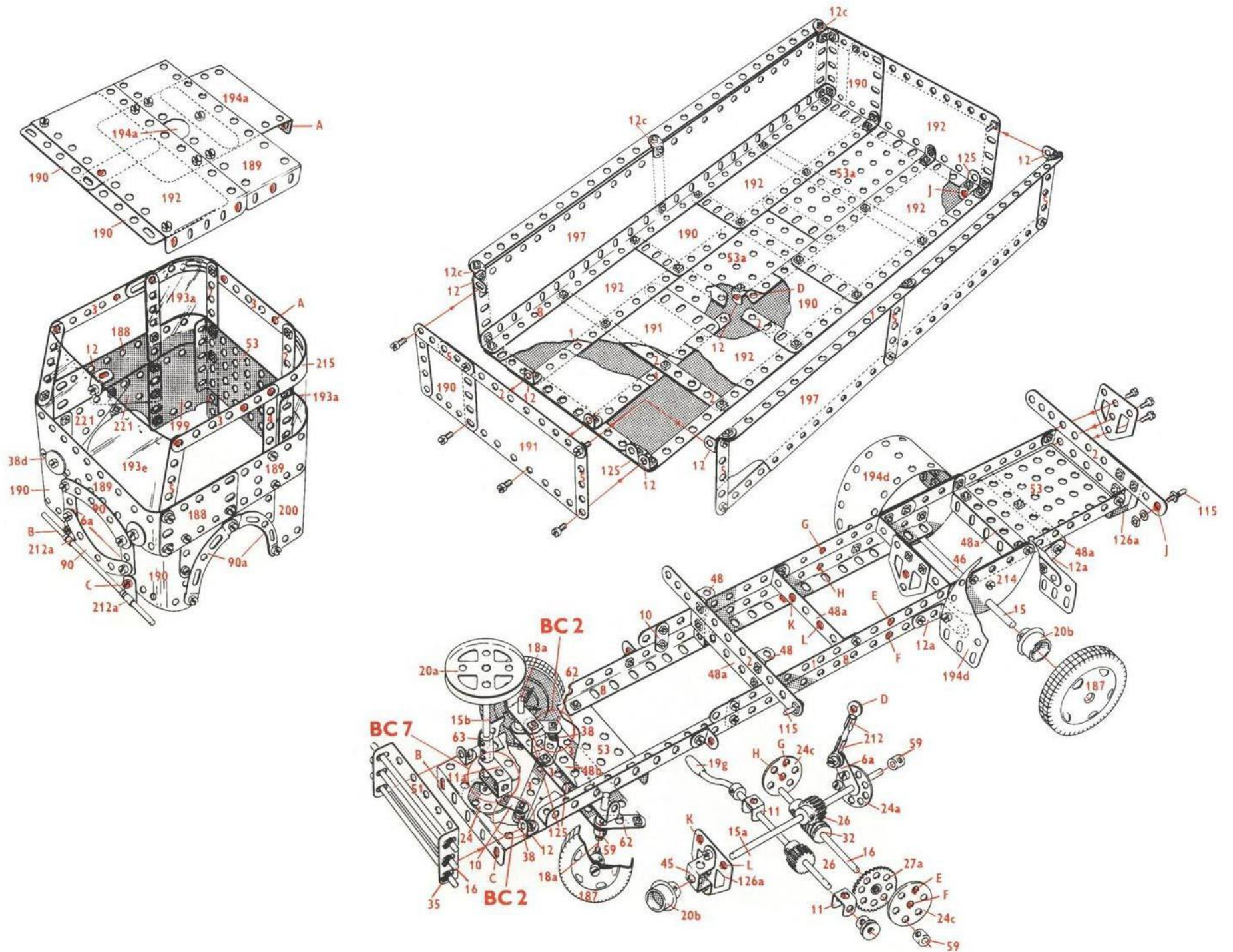

8.6 Bateau pompe
Boat pump
Pompboot
Batello pompa
Feuerlöschboot
Buque-bomba

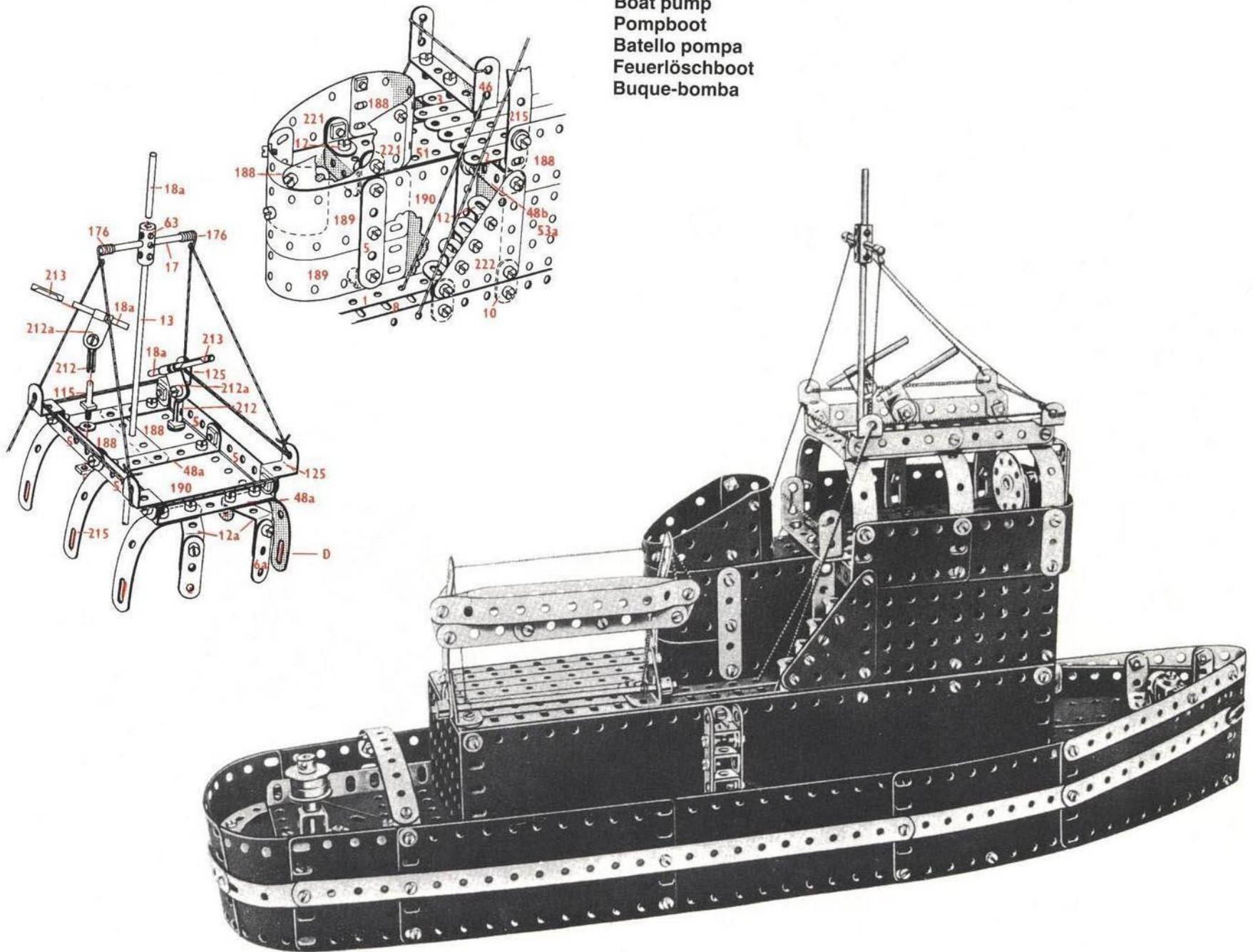

8 . 6

10 - 1	1 - 18b	2 - 54	6 - 192
16 - 2	2 - 20b	4 - 59	2 - 194
5 - 3	1 - 23a	1 - 63	2 - 194a
2 - 4	2 - 24	1 - 80c	1 - 194d
14 - 5	1 - 26	1 - 90	2 - 197
4 - 6a	194 - 37a	4 - 90a	1 - 199
4 - 8	184 - 37b	4 - 111c	2 - 212
12 - 10	21 - 38	2 - 115	2 - 212a
4 - 11	1 - 40	4 - 125	2 - 213
1 - 11a	2 - 45	2 - 126	1 - 214
14 - 12	1 - 46	1 - 164	8 - 215
4 - 12a	4 - 48a	2 - 176	4 - 221
2 - 12c	2 - 48b	1 - 186	2 - 222
1 - 13	1 - 51	4 - 188	2 - 223
1 - 15	2 - 52	6 - 189	
2 - 17	3 - 53	8 - 190	
4 - 18a	2 - 53a	2 - 191	

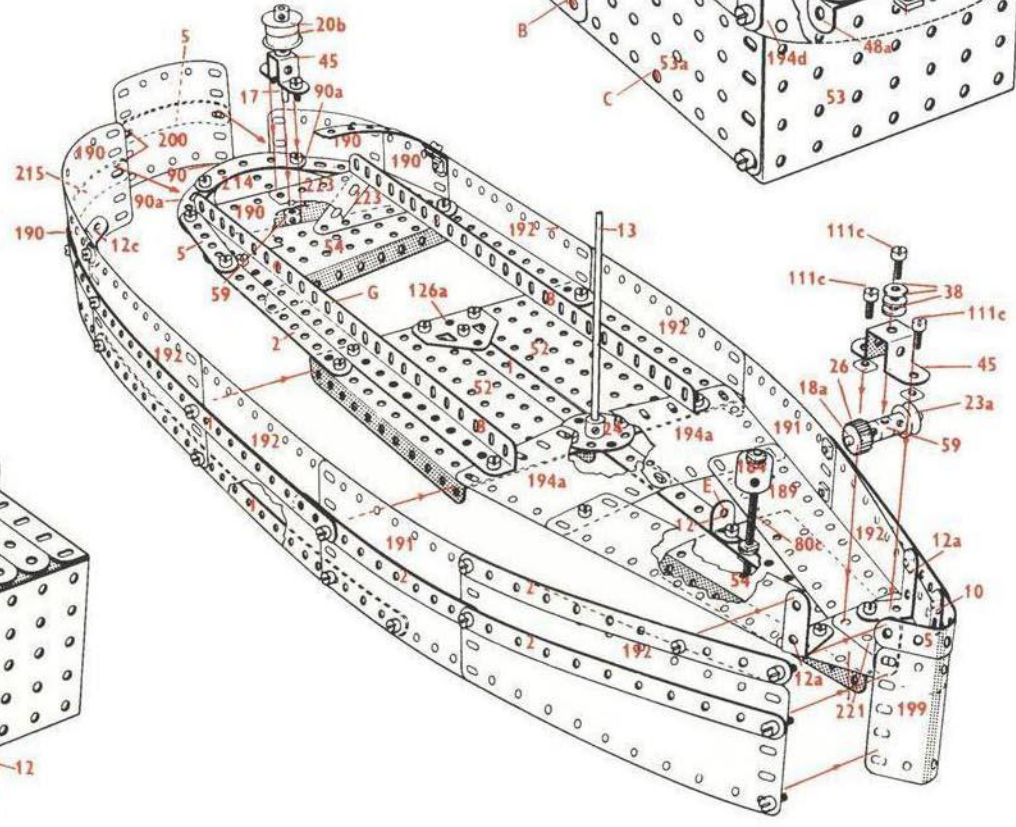
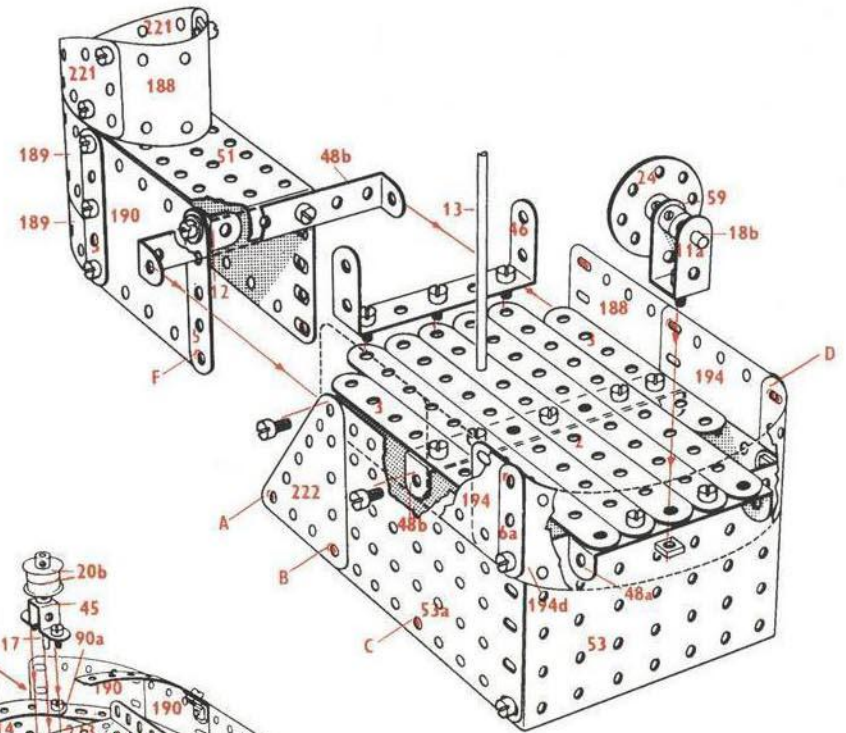
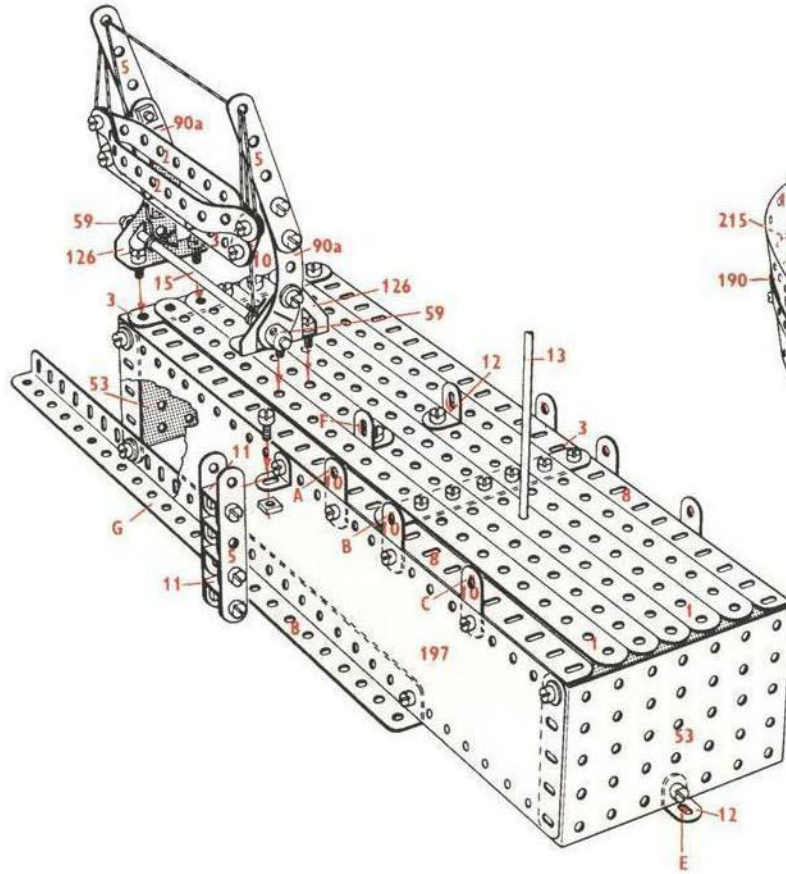

8.7 Distributeur automatique
 Automatic distributor
 Automatische verdeler
 Distributore automatico
 Automatischer verteiler
 Distribuidor automático

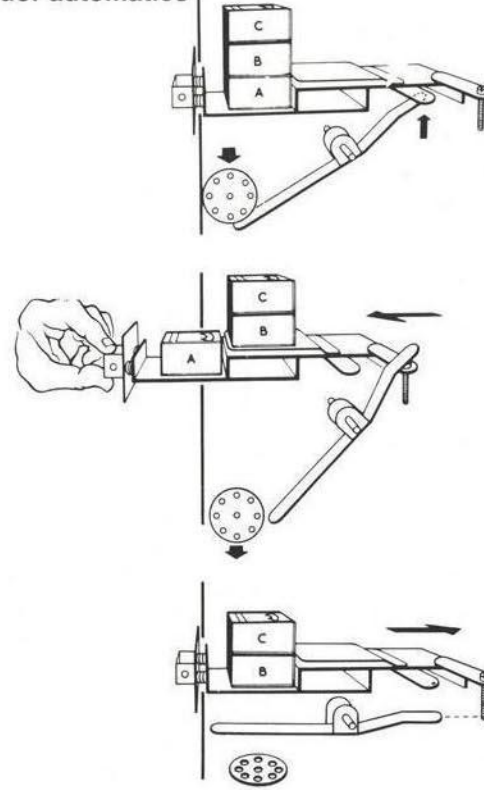
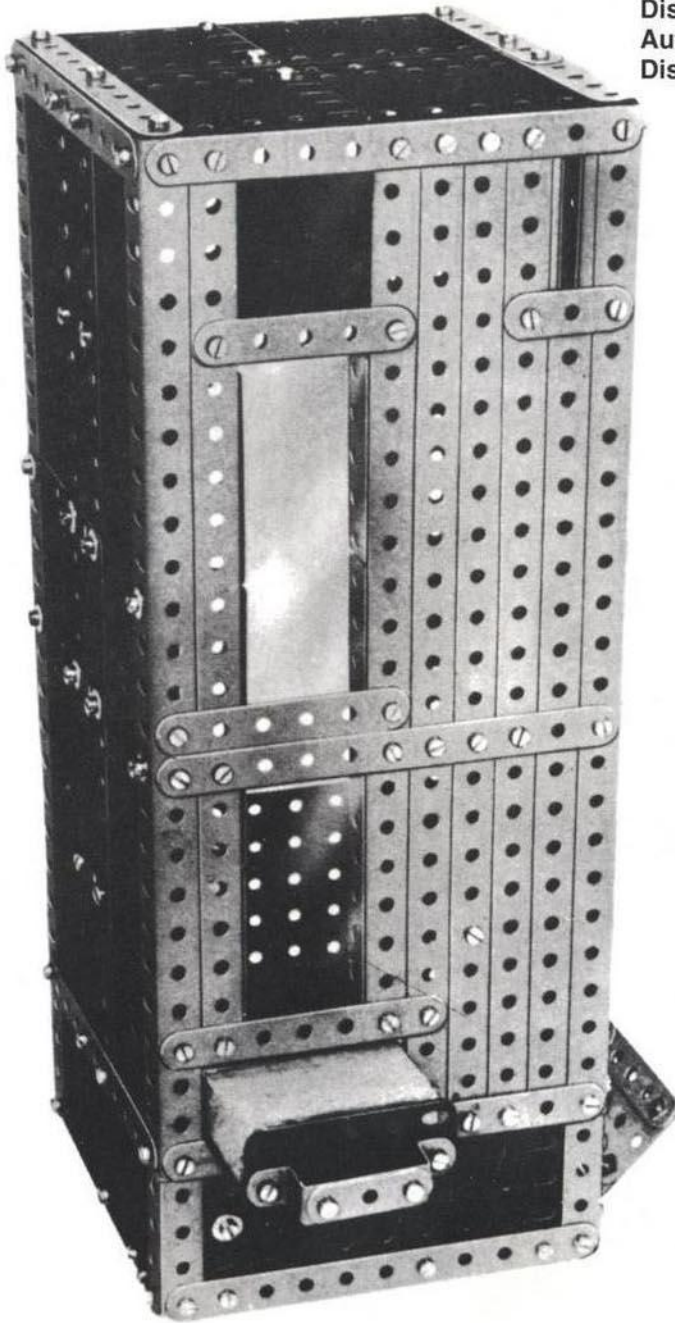

8.7

9	-	1	2	-	52
18	-	2	3	-	53
6	-	3	2	-	53a
2	-	4	5	-	59
4	-	6a	2	-	62
8	-	8	1	-	111
4	-	11	2	-	111a
1	-	11a	1	-	111c
12	-	12	2	-	125
1	-	12a	2	-	126a
2	-	15	5	-	188
1	-	15a	4	-	189
1	-	17	6	-	190
2	-	35	2	-	191
165	-	37a	6	-	192
155	-	37b	1	-	193a
26	-	38	1	-	193c
2	-	45	1	-	193e
1	-	48	2	-	194
10	-	48a	2	-	197
2	-	48b	2	-	212a

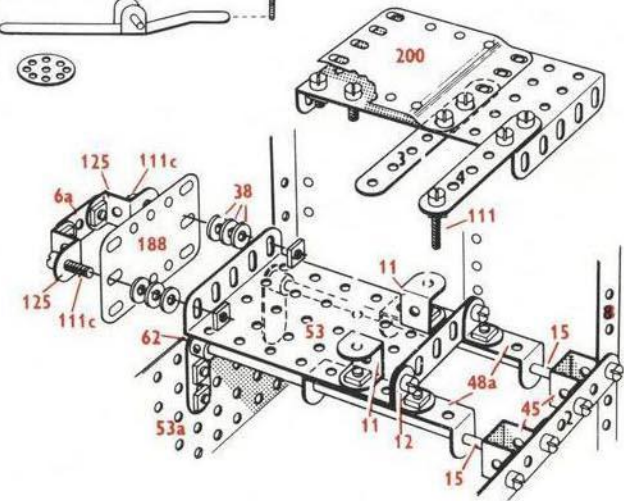

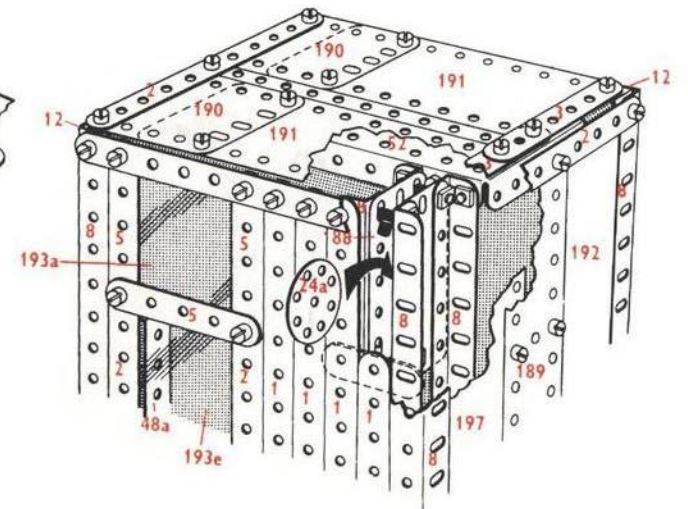
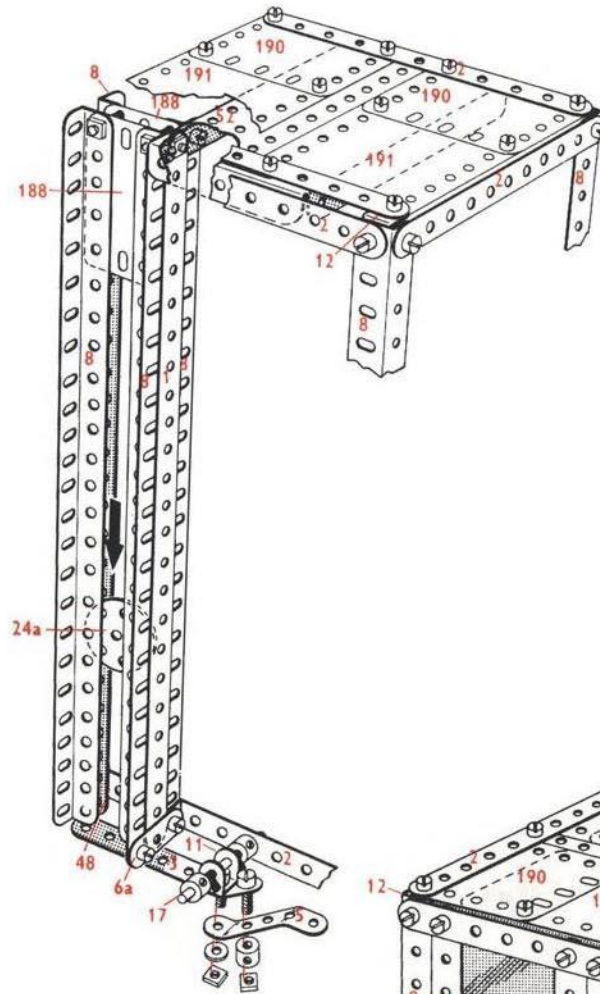
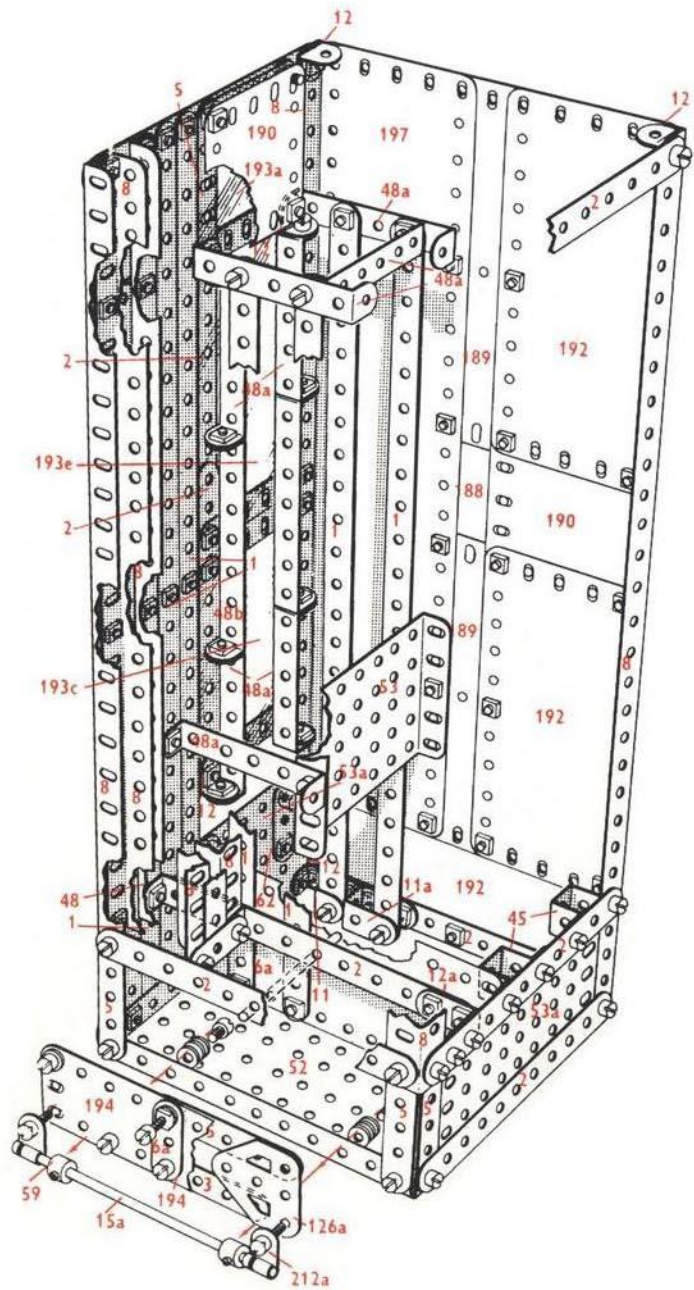

8.8 Balance automatique
 Automatic scale
 Automatische balans
 Bilancia automatica
 Automatische waage
 Balanza automática

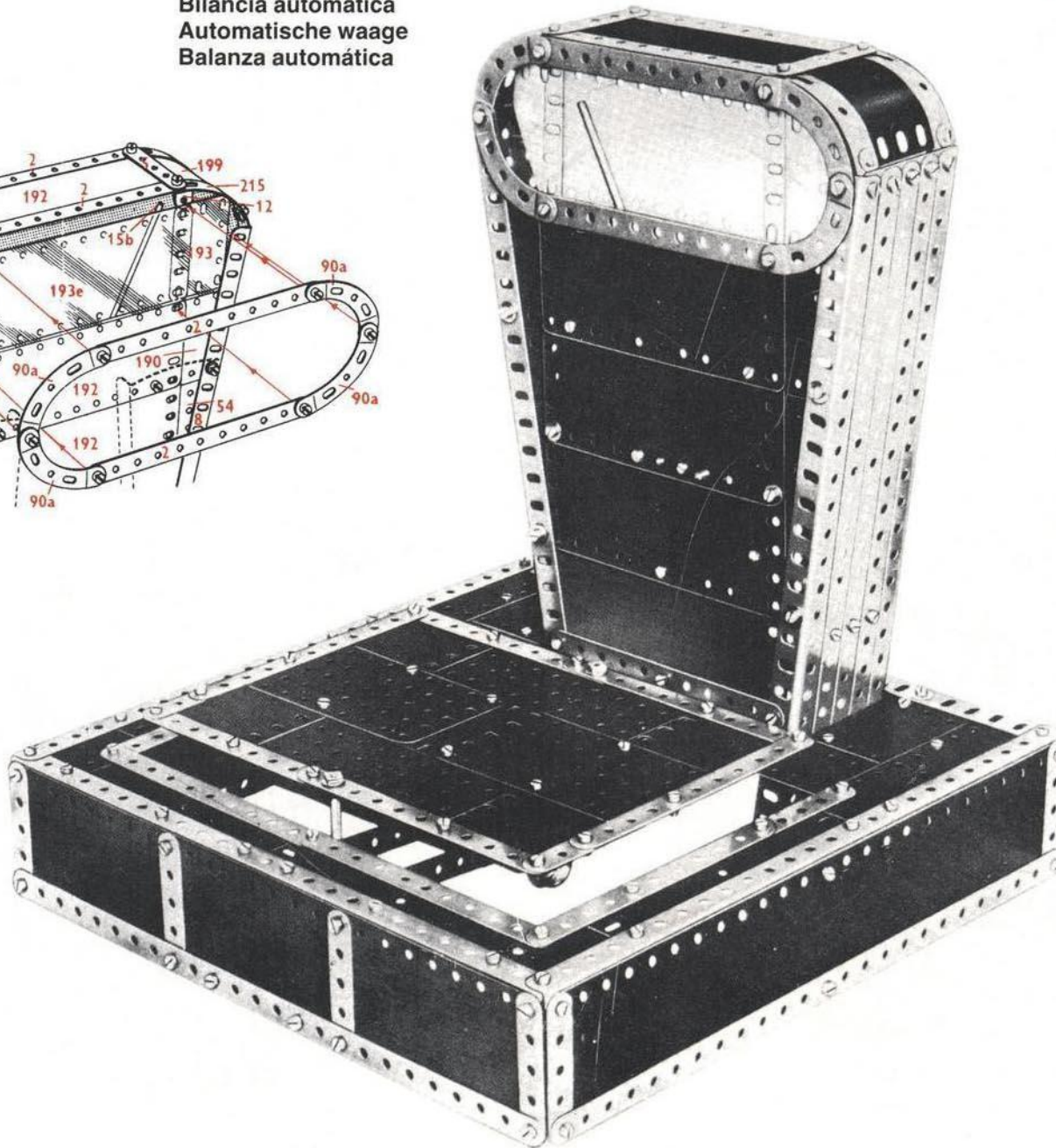
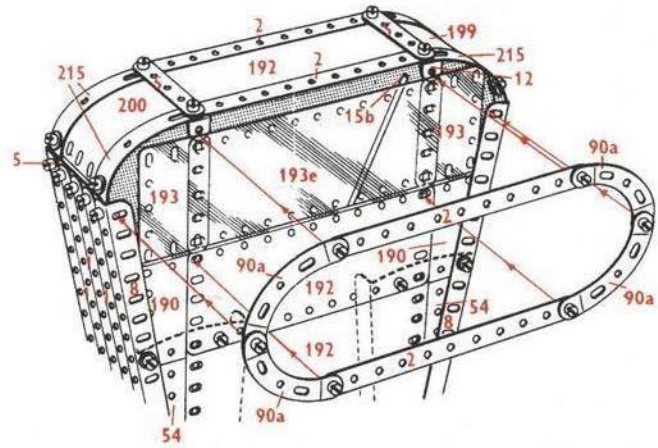

8.8

12	-	1	2	-	53
18	-	2	2	-	53a
2	-	3	2	-	54
2	-	4	6	-	59
12	-	5	1	-	62
4	-	6a	1	-	63
8	-	8	4	-	90
2	-	10	1	-	111
2	-	11	1	-	111a
1	-	11a	3	-	111c
14	-	12	2	-	115
2	-	12a	3	-	125
1	-	15a	2	-	126
1	-	15b	2	-	126a
3	-	16	1	-	186a
1	-	17	6	-	188
1	-	18a	4	-	189
1	-	18b	6	-	190
2	-	20b	5	-	192
2	-	24	2	-	193
1	-	26	1	-	193e
1	-	27a	2	-	194
191	-	37a	2	-	194a
183	-	37b	2	-	194d
29	-	38	3	-	197
2	-	45	1	-	199
2	-	48	1	-	200
10	-	48a	1	-	212
1	-	51	2	-	213
2	-	52	4	-	215

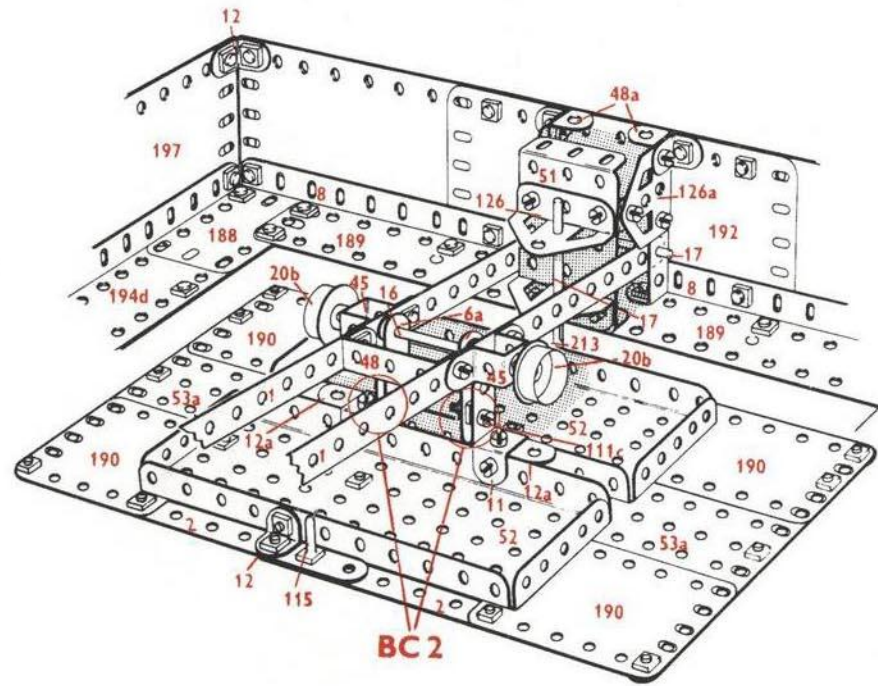
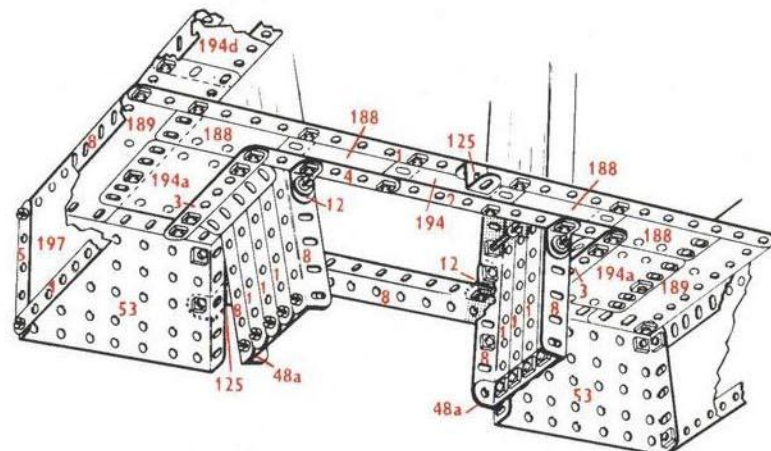
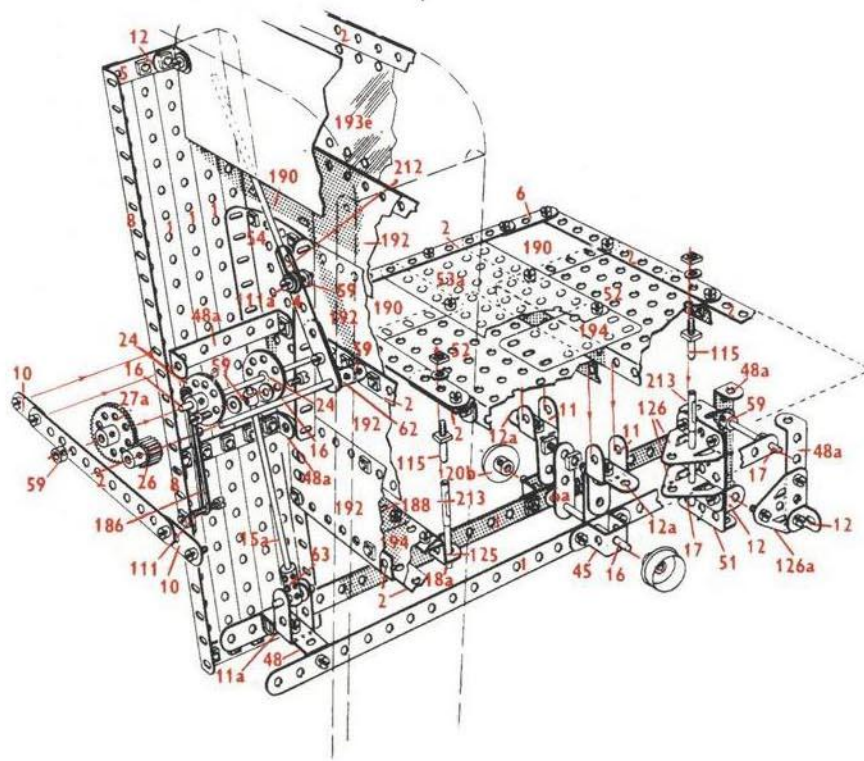
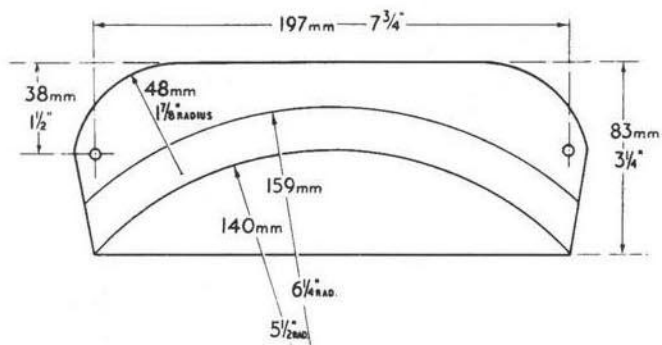

8.9 Hovercraft
 Hovercraft
 Hovercraft
 Veicolo a cuscinetti d'aria (hovercraft)
 Hovercraft
 Aerodeslizador

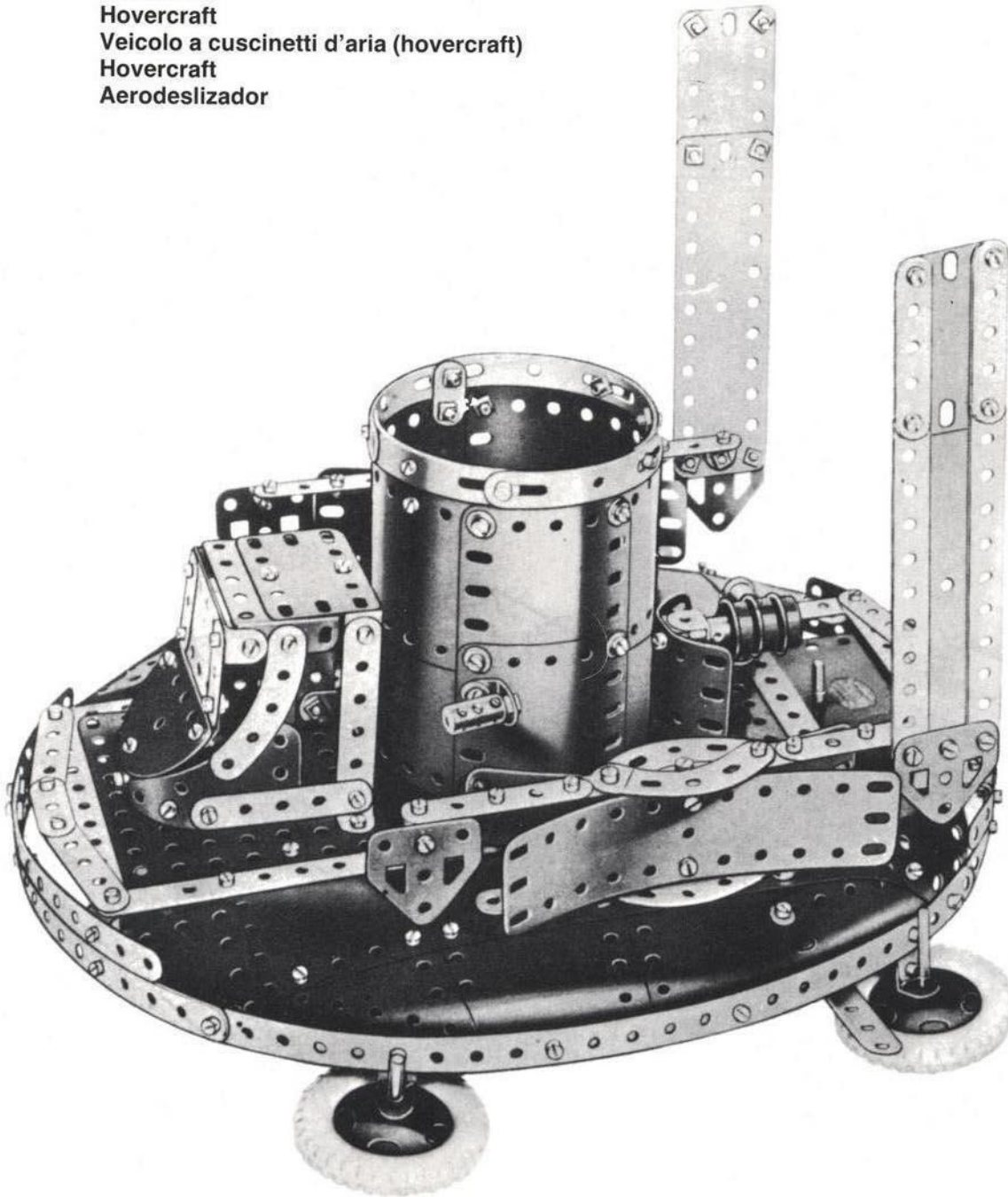

8.9

5 - 1	1 - 54
17 - 2	6 - 59
3 - 3	1 - 62
2 - 4	1 - 63
14 - 5	1 - 90
4 - 6a	8 - 90a
8 - 10	2 - 111
5 - 11	1 - 111a
1 - 11a	6 - 111c
10 - 12	1 - 115
4 - 12a	3 - 125
4 - 12c	2 - 126
1 - 15a	3 - 126a
2 - 17	4 - 142c
4 - 18a	4 - 187
1 - 20a	6 - 188
4 - 22	4 - 189
1 - 24	4 - 190
1 - 26	2 - 191
1 - 32	6 - 192
5 - 35	1 - 193
178 - 37a	1 - 193d
160 - 37b	2 - 194
20 - 38	2 - 194d
2 - 48	2 - 200
3 - 48a	1 - 214
1 - 48b	6 - 215
1 - 51	2 - 221
1 - 52	2 - 222
2 - 53a	2 - 223

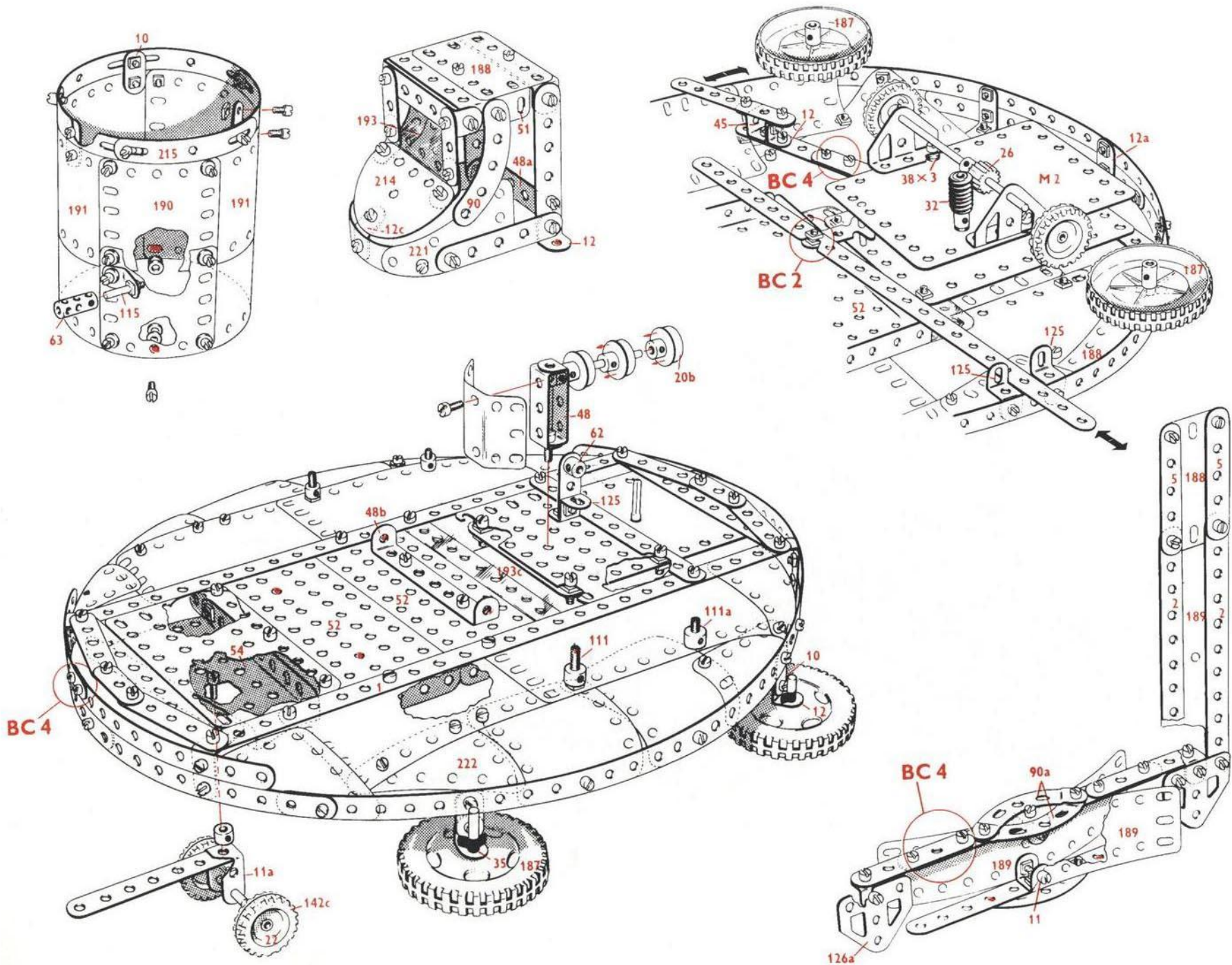

8.10 Jeep
 Jeep
 Jeep
 Jeep
 Geländeauto
 Jeep

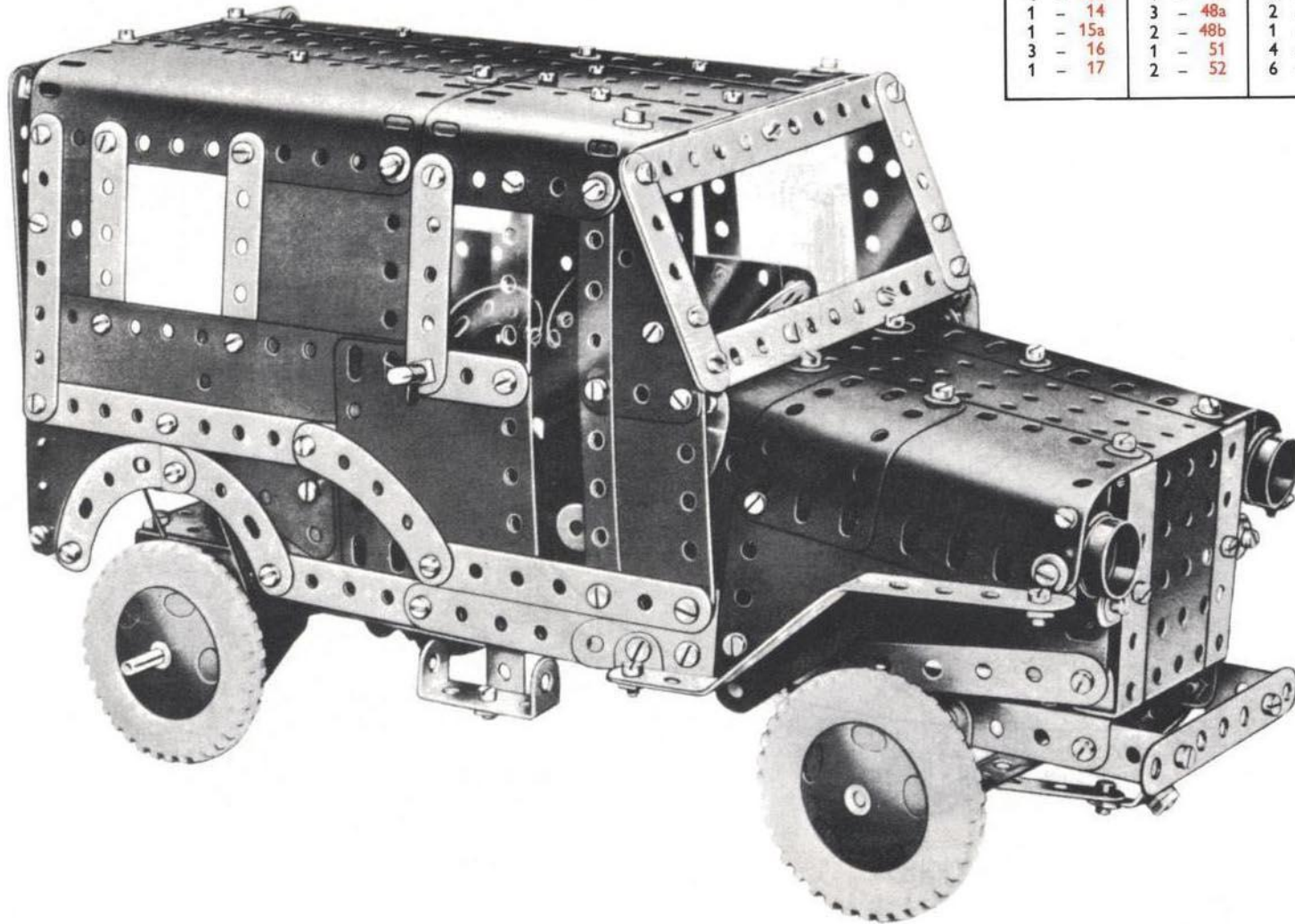

8.10

14 - 2	2 - 18a	1 - 53	3 - 189
6 - 3	4 - 20b	2 - 53a	8 - 190
1 - 4	2 - 22	6 - 59	2 - 191
12 - 5	2 - 24	1 - 63	2 - 192
4 - 6a	1 - 24c	1 - 90	2 - 193
2 - 8	1 - 26	8 - 90a	2 - 193d
6 - 10	1 - 32	1 - 111	2 - 194
2 - 11	2 - 35	1 - 111a	2 - 194a
1 - 11a	158 - 37a	5 - 111c	2 - 194d
18 - 12	150 - 37b	2 - 115	2 - 212
4 - 12a	28 - 38	1 - 125	2 - 214
4 - 12c	1 - 46	2 - 126	4 - 221
1 - 14	3 - 48a	2 - 126a	2 - 222
1 - 15a	2 - 48b	1 - 186	2 - 223
3 - 16	1 - 51	4 - 187	
1 - 17	2 - 52	6 - 188	

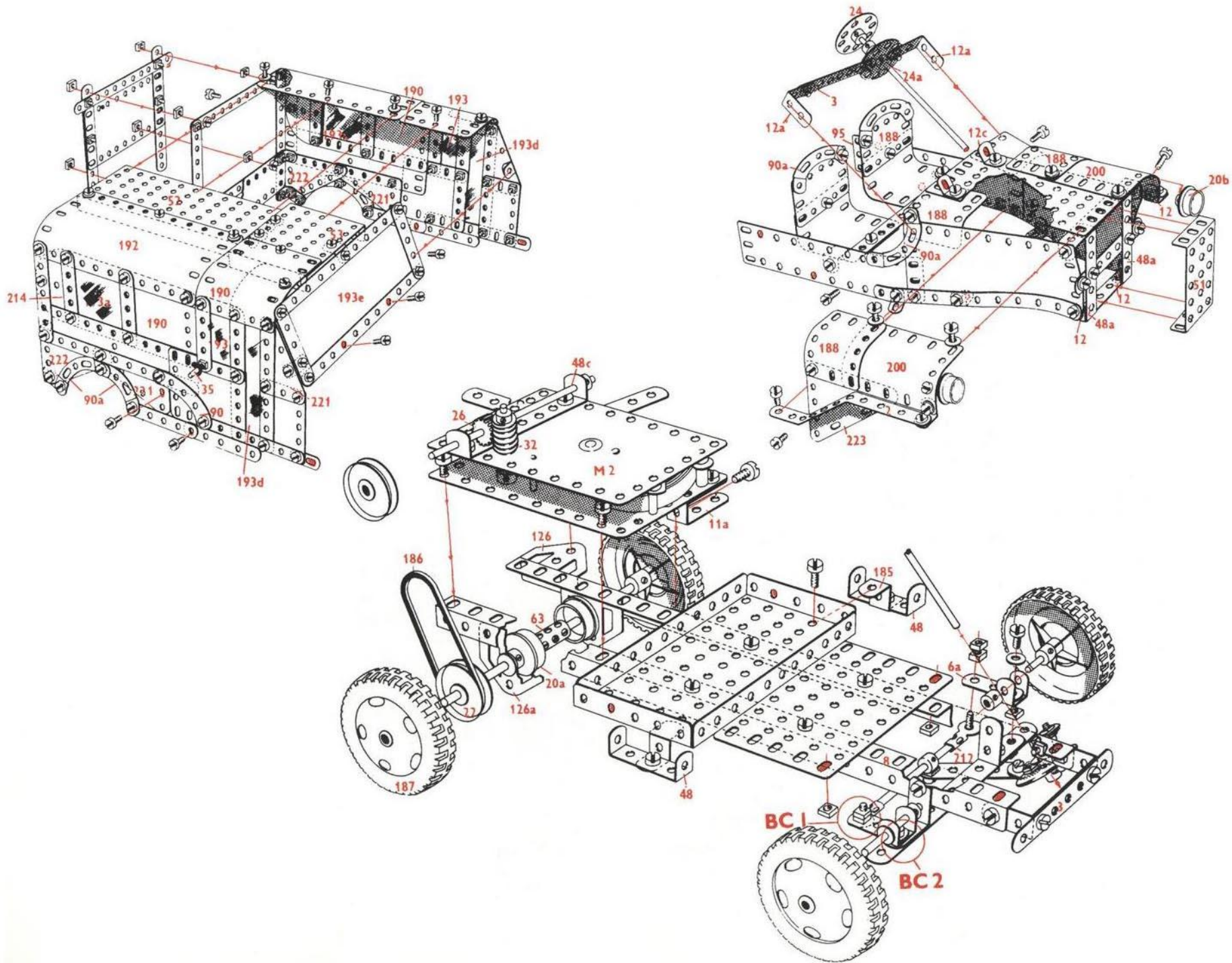

8.11 Tracteur à benne fond ouvrant
 Dumper lorry
 Tractor en grïjpbak
 Trattore e bigoncia da fondo ribaltabile
 Schlepper und greifer mit kippboden
 Tractor de trailla de descarga por el fondo

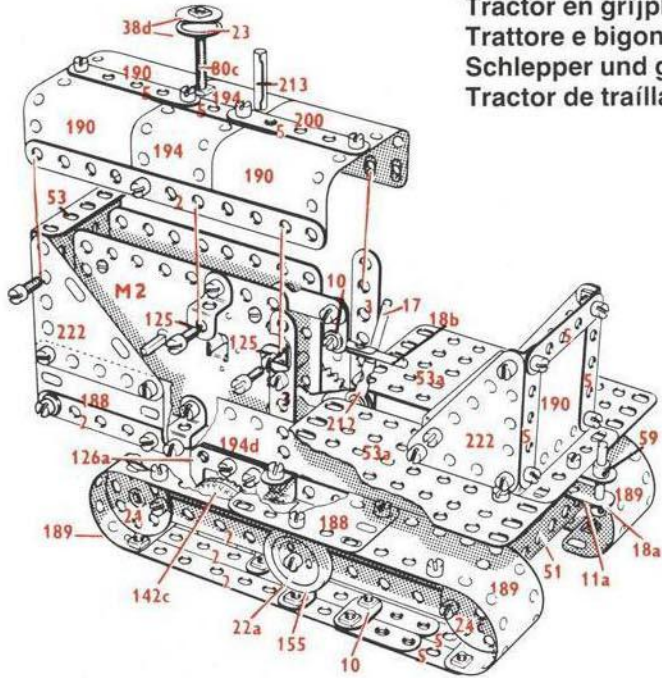

8.11

8	-	1	2	-	24	3	-	125
18	-	2	2	-	24c	2	-	126
6	-	3	2	-	26	4	-	126a
2	-	4	1	-	27a	4	-	142c
12	-	5	2	-	35	2	-	155
4	-	6a	171	-	37a	1	-	176
4	-	8	161	-	37b	1	-	186
12	-	10	27	-	38	1	-	186a
2	-	11	2	-	38d	4	-	187
1	-	11a	1	-	40	6	-	188
16	-	12	1	-	46	4	-	189
4	-	12a	2	-	48	6	-	190
1	-	13	8	-	48a	2	-	194
1	-	14	1	-	48b	2	-	194d
1	-	15b	1	-	51	1	-	199
1	-	16	3	-	53	1	-	200
2	-	17	2	-	53a	2	-	212
4	-	18a	6	-	59	2	-	212a
1	-	18b	2	-	62	2	-	213
1	-	19g	1	-	80c	2	-	214
5	-	22	2	-	90	4	-	215
2	-	22a	2	-	111	4	-	221
1	-	23	2	-	111a	2	-	222
1	-	23a	2	-	115	2	-	223

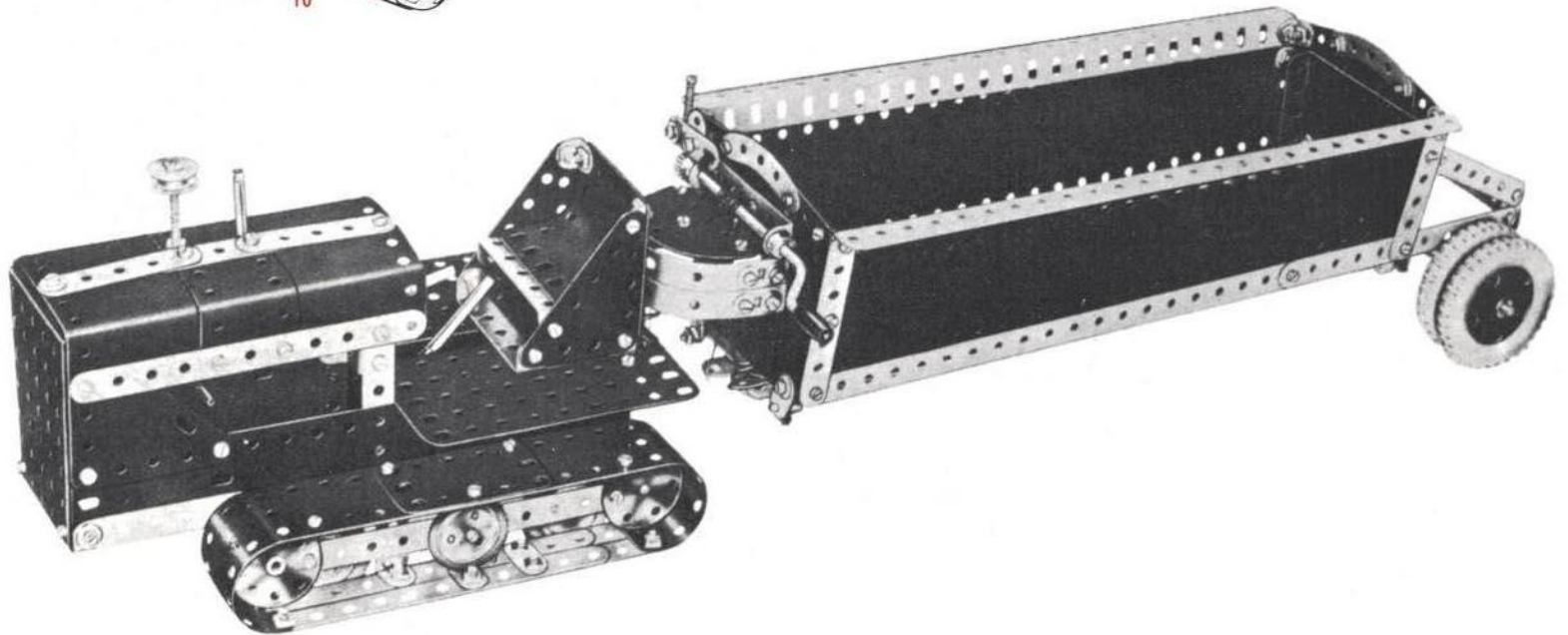

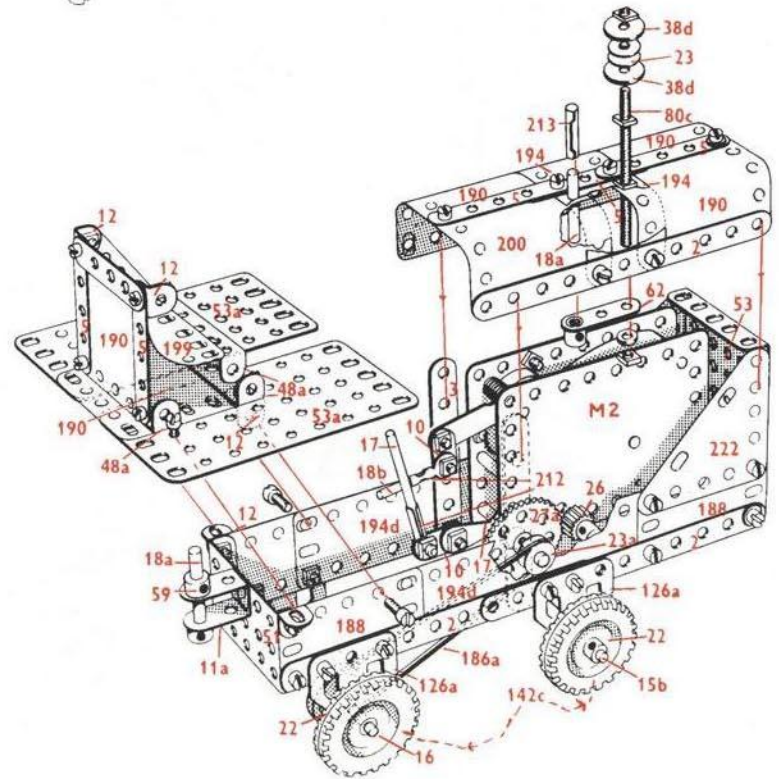
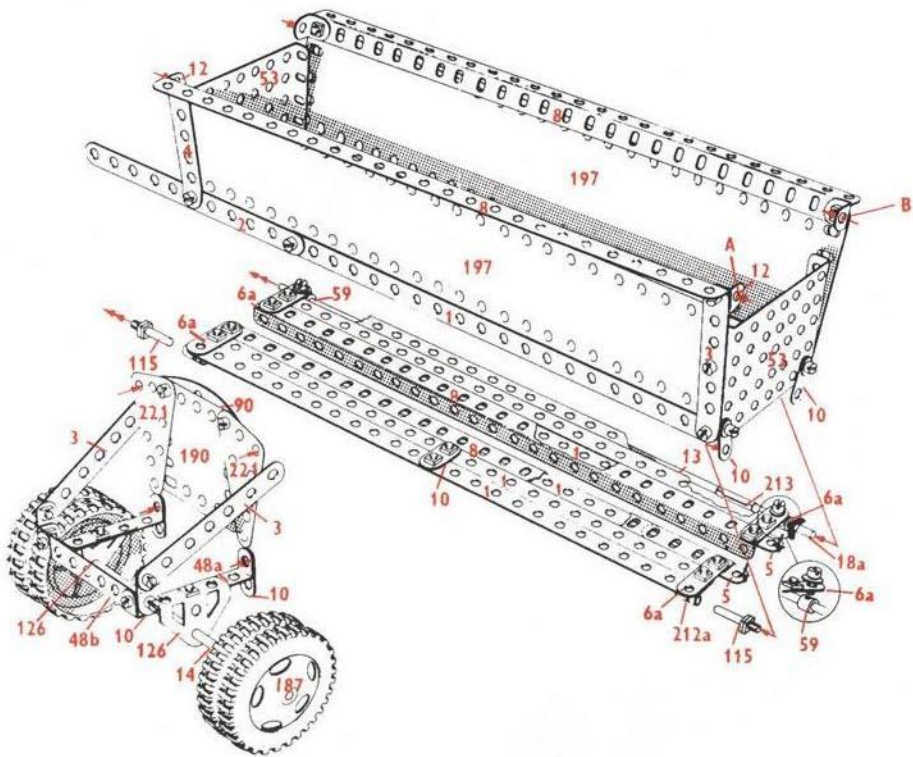
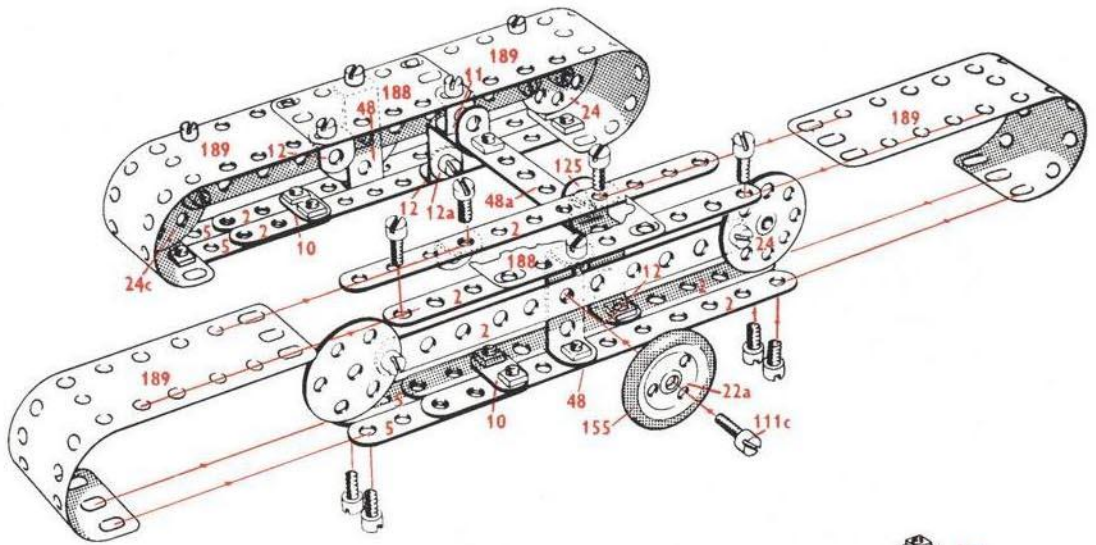
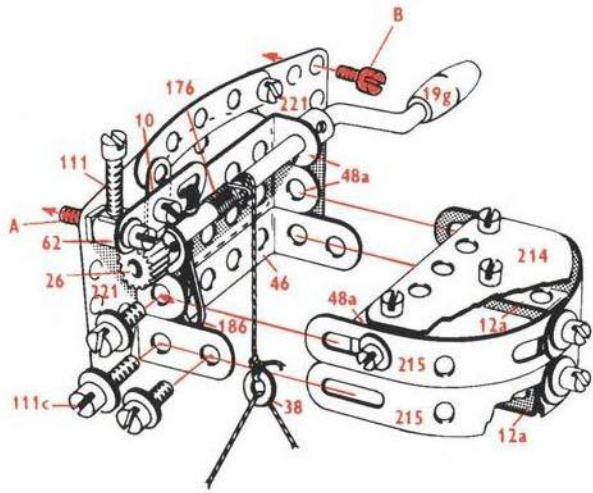

8.12. Téléphérique
 Cable car
 Kabelzweefbaan
 Teleferica
 Drahtseibahn
 Teleférico

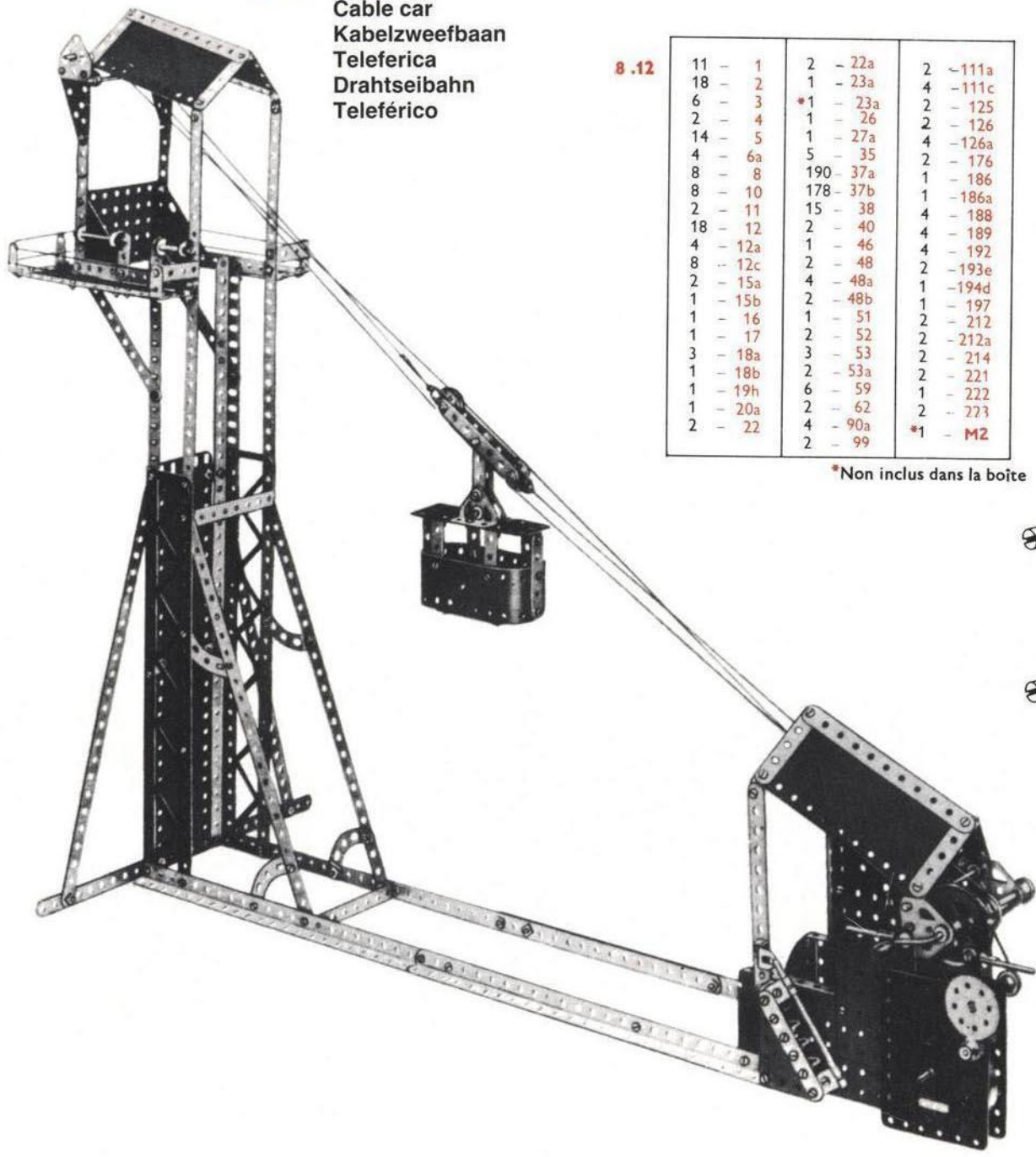

8.12

11 - 1	2 - 22a	2 - 111a
18 - 2	1 - 23a	4 - 111c
6 - 3	*1 - 23a	2 - 125
2 - 4	1 - 26	2 - 126
14 - 5	1 - 27a	4 - 126a
4 - 6a	5 - 35	2 - 176
8 - 8	190 - 37a	1 - 186
8 - 10	178 - 37b	1 - 186a
2 - 11	15 - 38	4 - 188
18 - 12	2 - 40	4 - 189
4 - 12a	1 - 46	4 - 192
8 - 12c	2 - 48	2 - 193e
2 - 15a	4 - 48a	1 - 194d
1 - 15b	2 - 48b	1 - 197
1 - 16	1 - 51	2 - 212
1 - 17	2 - 52	2 - 212a
3 - 18a	3 - 53	2 - 214
1 - 18b	2 - 53a	2 - 221
1 - 19h	6 - 59	1 - 222
1 - 20a	2 - 62	2 - 223
2 - 22	4 - 90a	*1 - M2
	2 - 99	

*Non inclus dans la boîte

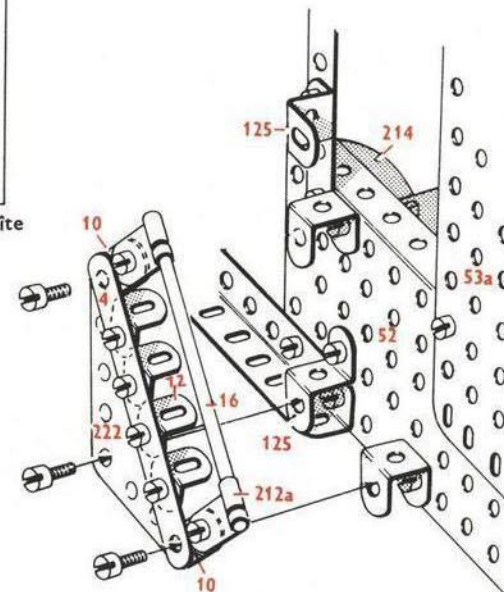

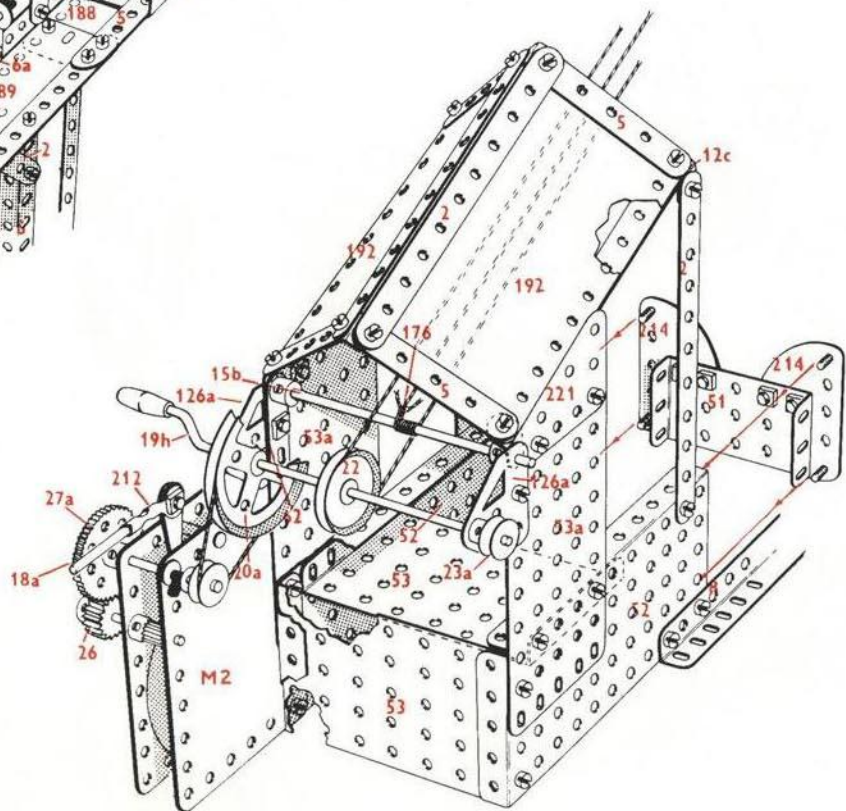
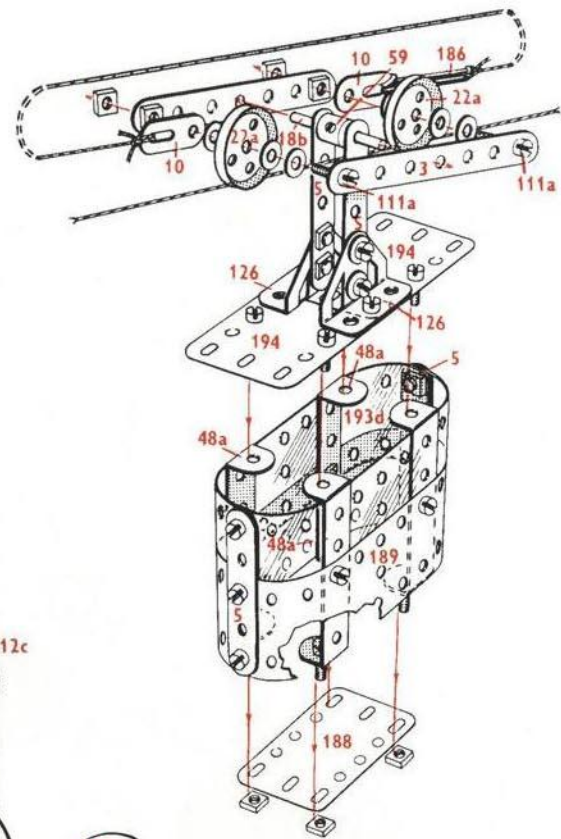
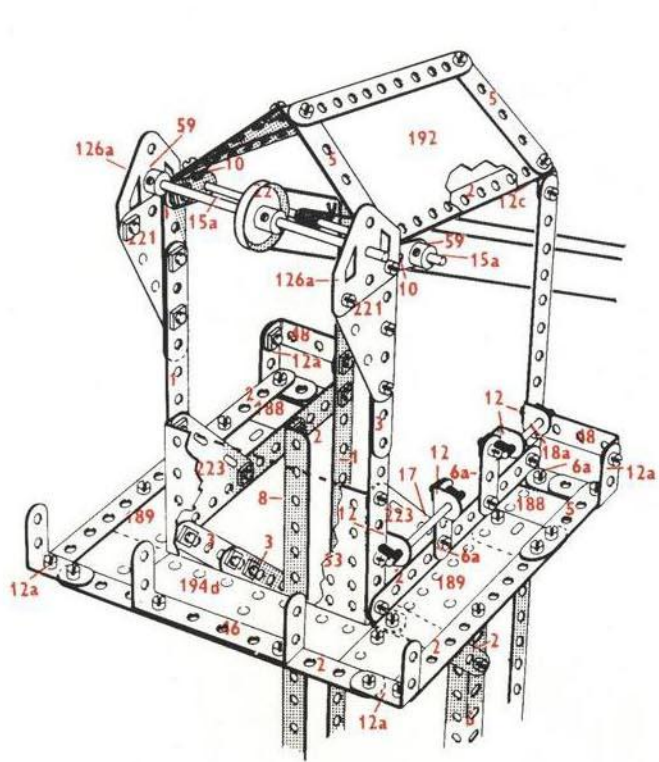

Balançoise foraine
 Swingboat
 Kermisshommel
 Altalena da feira
 Jahmarktschaukel
 Columpio de feria

8.13

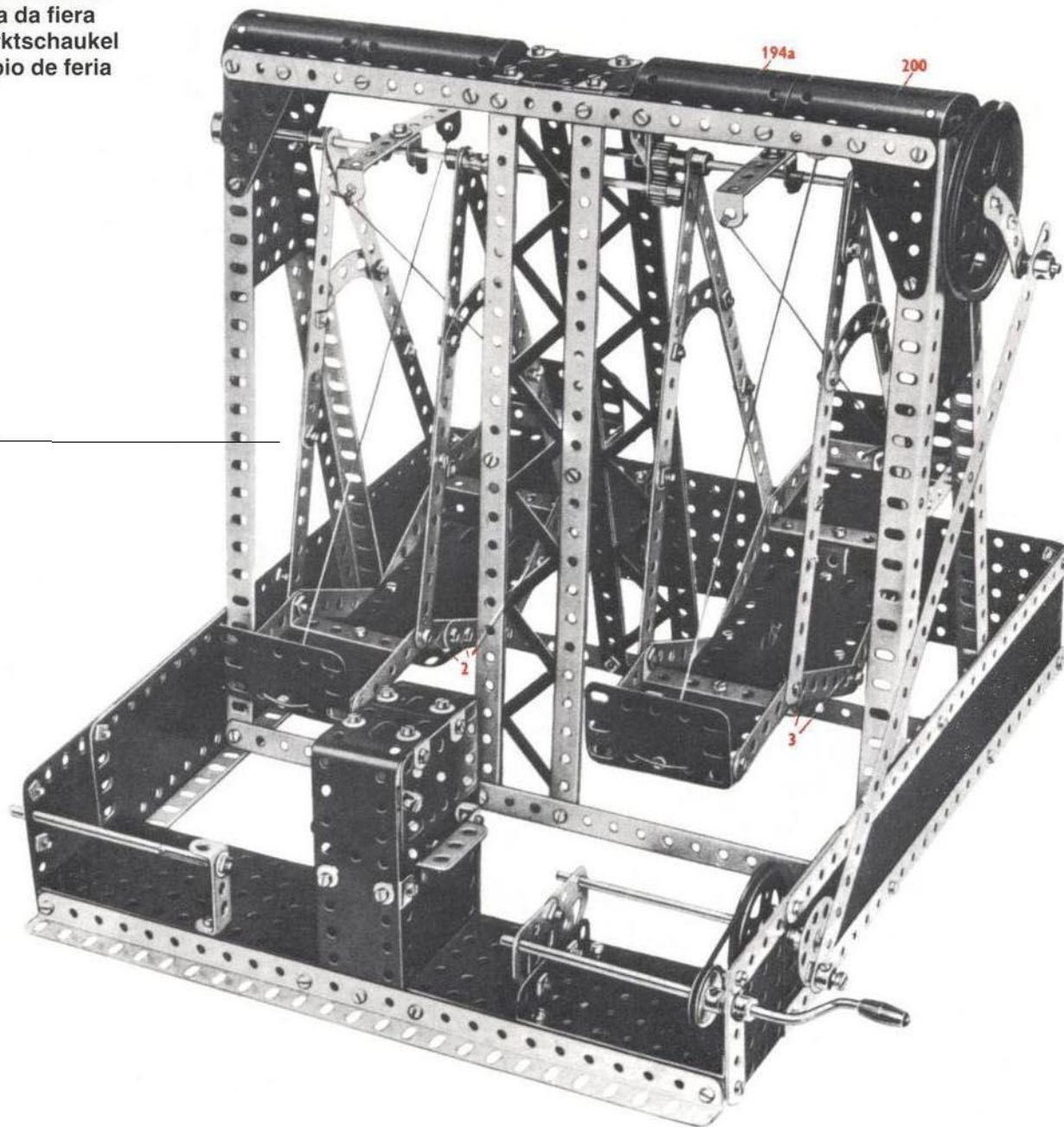

8.13

12	-	1	2	-	52
16	-	2	3	-	53
6	-	3	2	-	53a
2	-	4	2	-	54
13	-	5	6	-	59
4	-	6a	2	-	62
8	-	8	1	-	63
2	-	11	2	-	90
16	-	12	4	-	90a
1	-	14	2	-	99
1	-	15	2	-	115
1	-	15a	4	-	125
2	-	16	2	-	126
1	-	19b	4	-	126a
1	-	19h	1	-	147b
1	-	20a	1	-	186a
1	-	20b	5	-	188
1	-	22	2	-	189
1	-	24	7	-	190
2	-	26	2	-	191
4	-	35	2	-	193
177	-	37a	2	-	194
177	-	37b	2	-	194a
24	-	38	2	-	197
1	-	40	1	-	199
1	-	48	1	-	200
10	-	48a	1	-	213
2	-	48b	4	-	221
1	-	51			

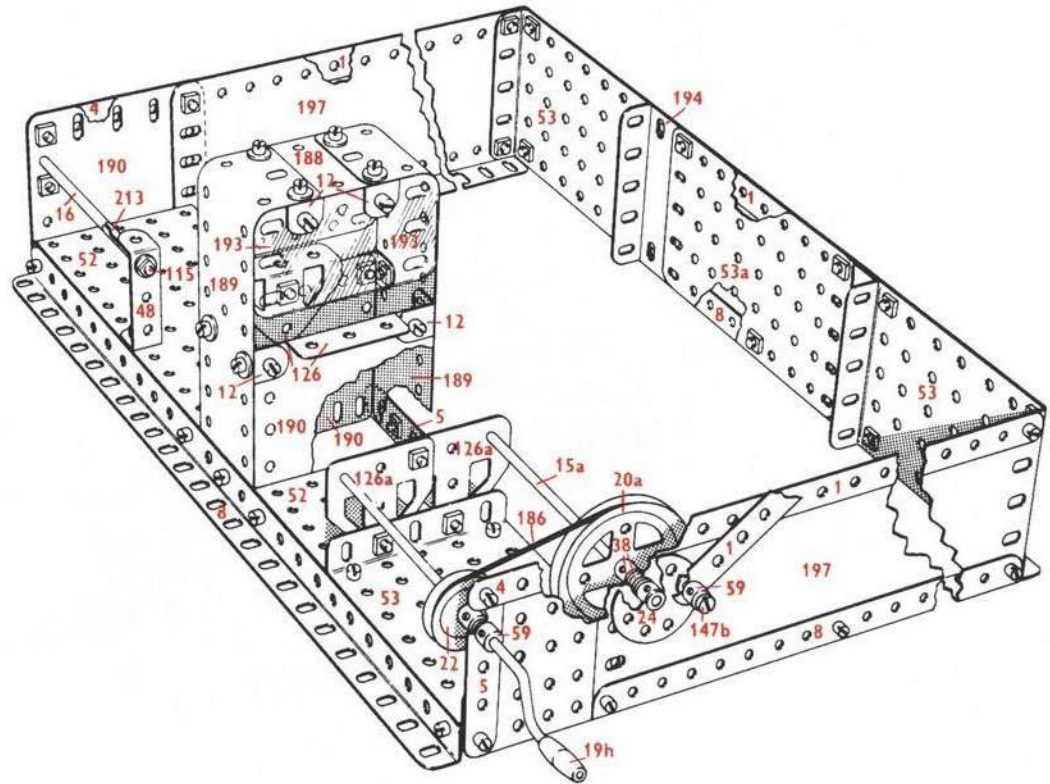
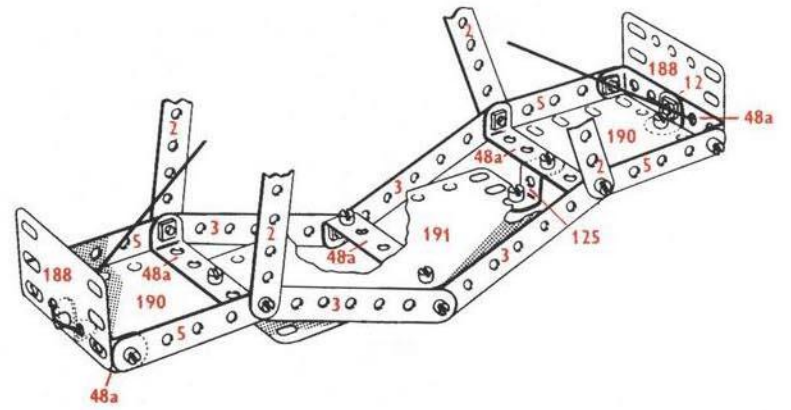
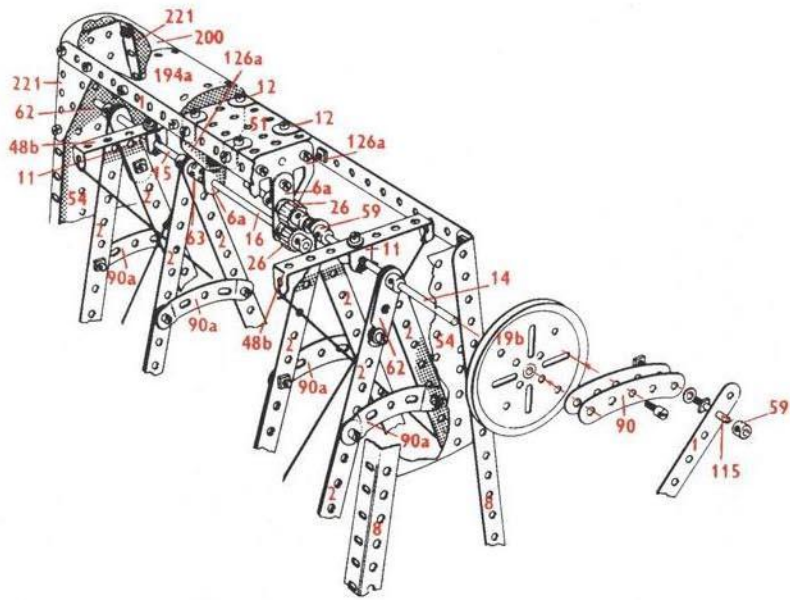

8.14 Presse hydraulique
 Drop forging press
 Hydraulische pers
 Pressa idraulica
 Hydraulische presse
 Prensa hidráulica

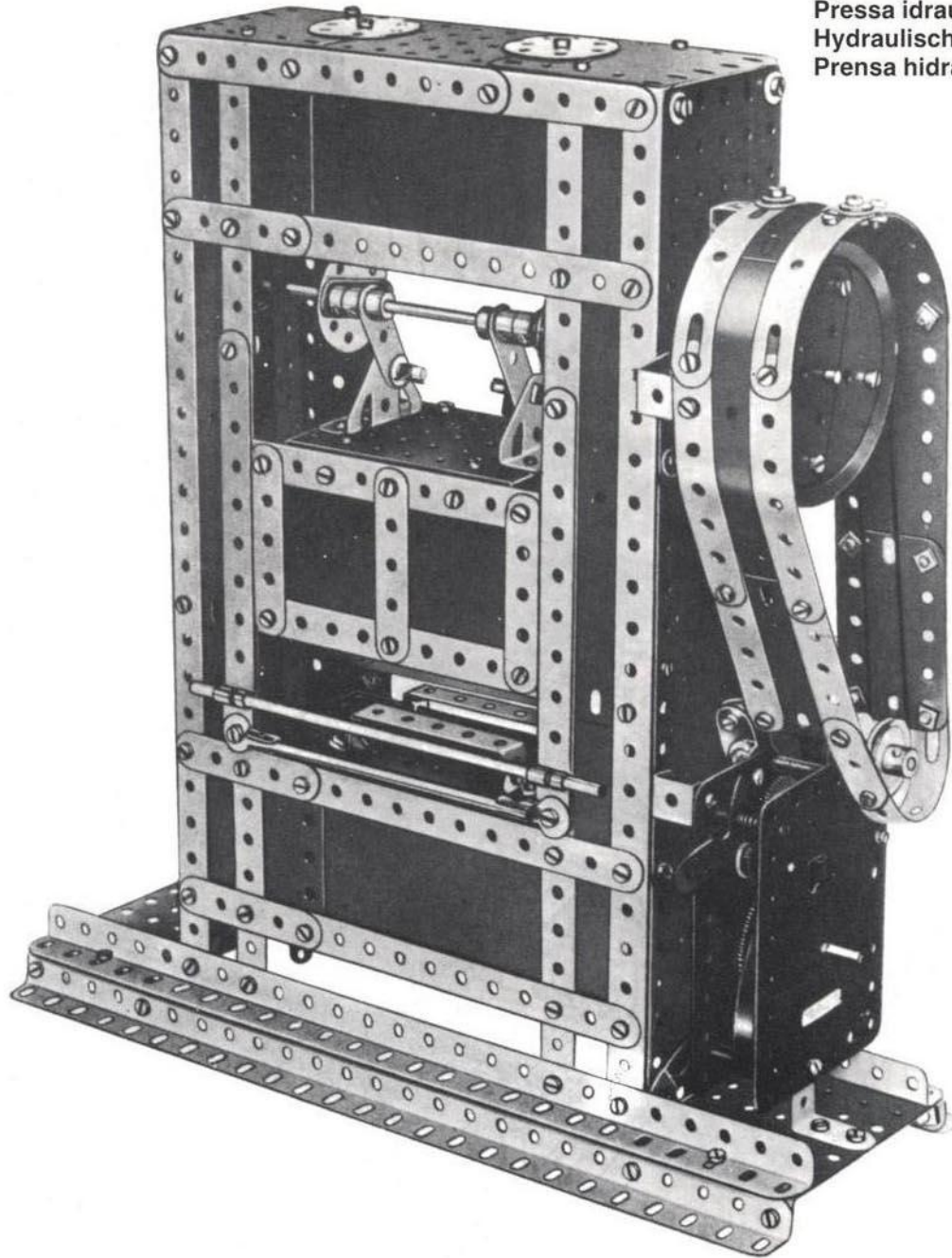

8.14

6	-	1	1	-	45
18	-	2	4	-	48a
6	-	3	1	-	48b
2	-	4	2	-	52
14	-	5	3	-	53
4	-	6a	2	-	53a
8	-	8	5	-	59
2	-	10	2	-	62
3	-	11	2	-	90a
9	-	12	2	-	111a
4	-	12a	4	-	111c
1	-	14	2	-	115
2	-	15a	1	-	125
1	-	15b	2	-	126
1	-	16	2	-	186b
1	-	17	5	-	188
2	-	19b	4	-	189
2	-	20b	8	-	190
2	-	22	2	-	191
2	-	24	6	-	192
2	-	24c	2	-	194
1	-	26	2	-	194a
1	-	27a	2	-	194d
2	-	35	2	-	212
181	-	37a	2	-	212a
175	-	37b	2	-	214
34	-	38	5	-	215
			*1	-	M2

* Non inclus dans la boîte

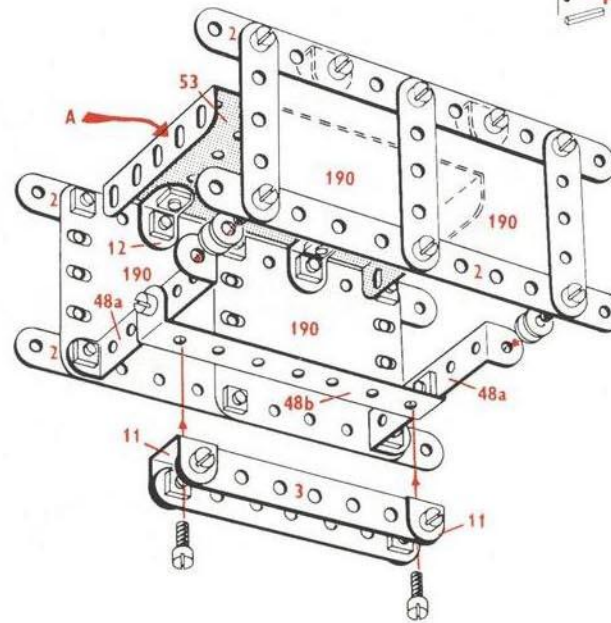
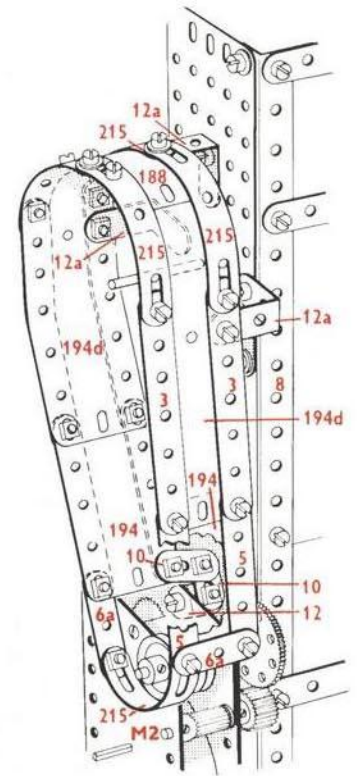
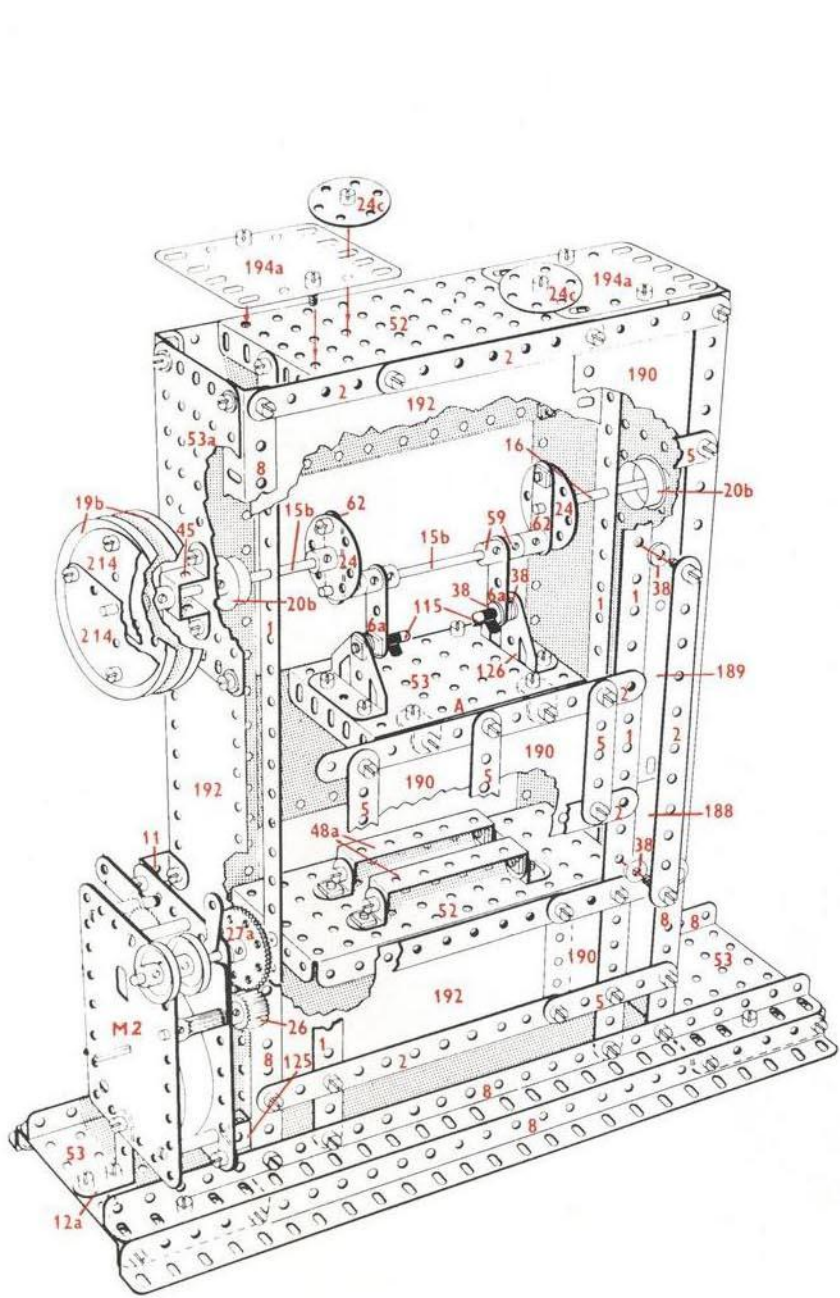

8.15

Etou limeur
 Filer vise
 Vijlschroef
 Morsa limatore
 Shaper
 Cepilladora

8.15

7	-	1	3	-	22	2	-	80c
17	-	2	1	-	23	2	-	111
6	-	3	1	-	24	2	-	111a
2	-	4	2	-	24c	2	-	111c
13	-	5	1	-	26	2	-	115
4	-	6a	1	-	27a	4	-	125
8	-	8	4	-	35	1	-	126
8	-	10	197	-	37a	1	-	126a
3	-	11	175	-	37b	2	-	176
1	-	11a	34	-	38	2	-	186b
17	-	12	1	-	38d	4	-	188
4	-	12a	2	-	48	3	-	189
2	-	15	11	-	48a	6	-	190
1	-	15a	1	-	51	2	-	191
1	-	15b	2	-	52	6	-	192
2	-	17	3	-	53	2	-	194a
2	-	18a	2	-	53a	1	-	199
1	-	18b	6	-	59	1	-	200
2	-	19b	2	-	62	1	-	212
1	-	20a	1	-	63	2	-	214
						1	-	M2

* Non inclus dans la boîte

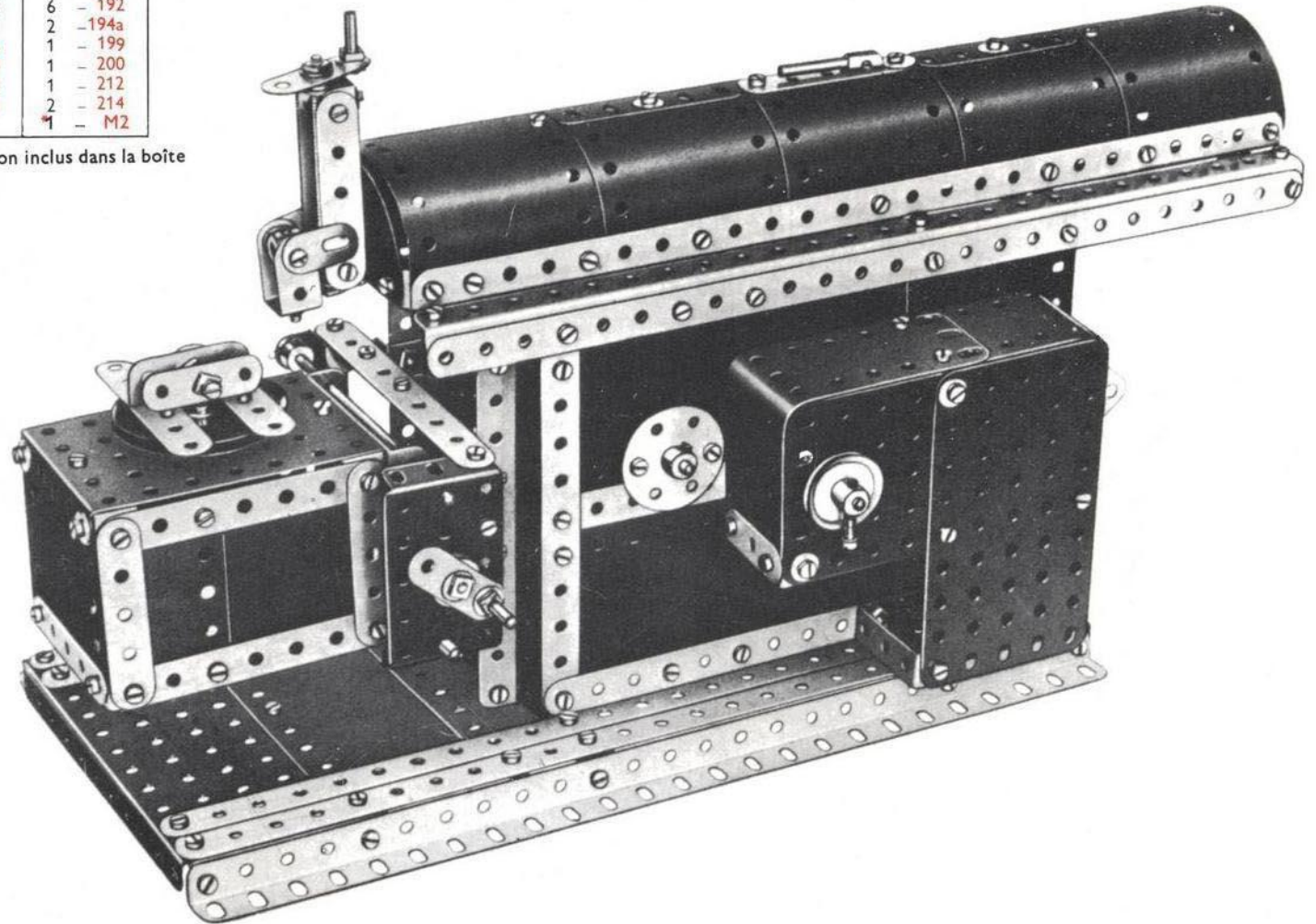

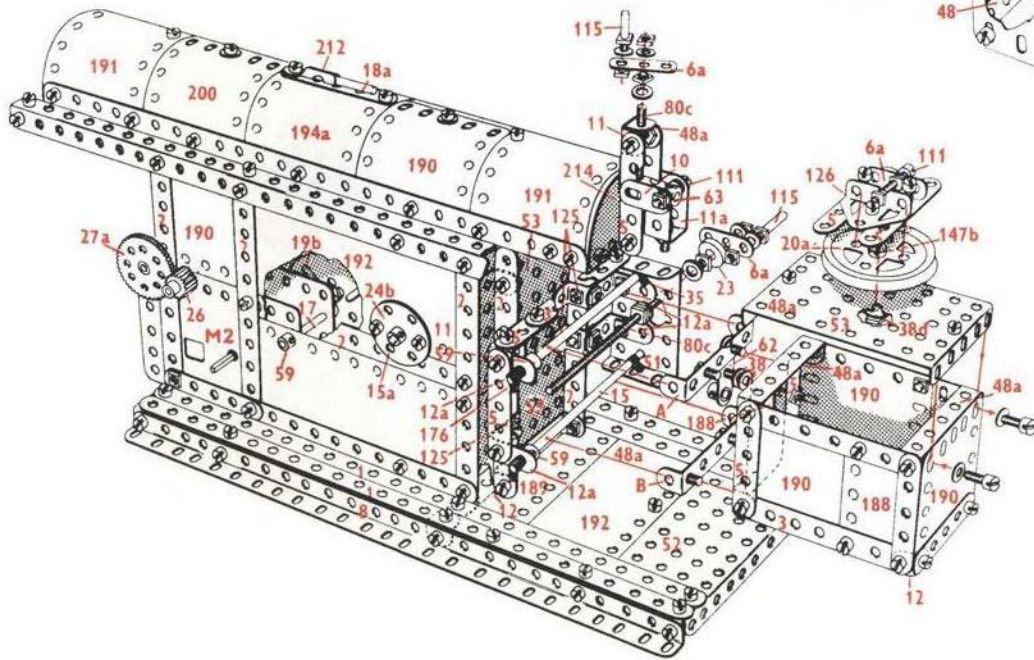
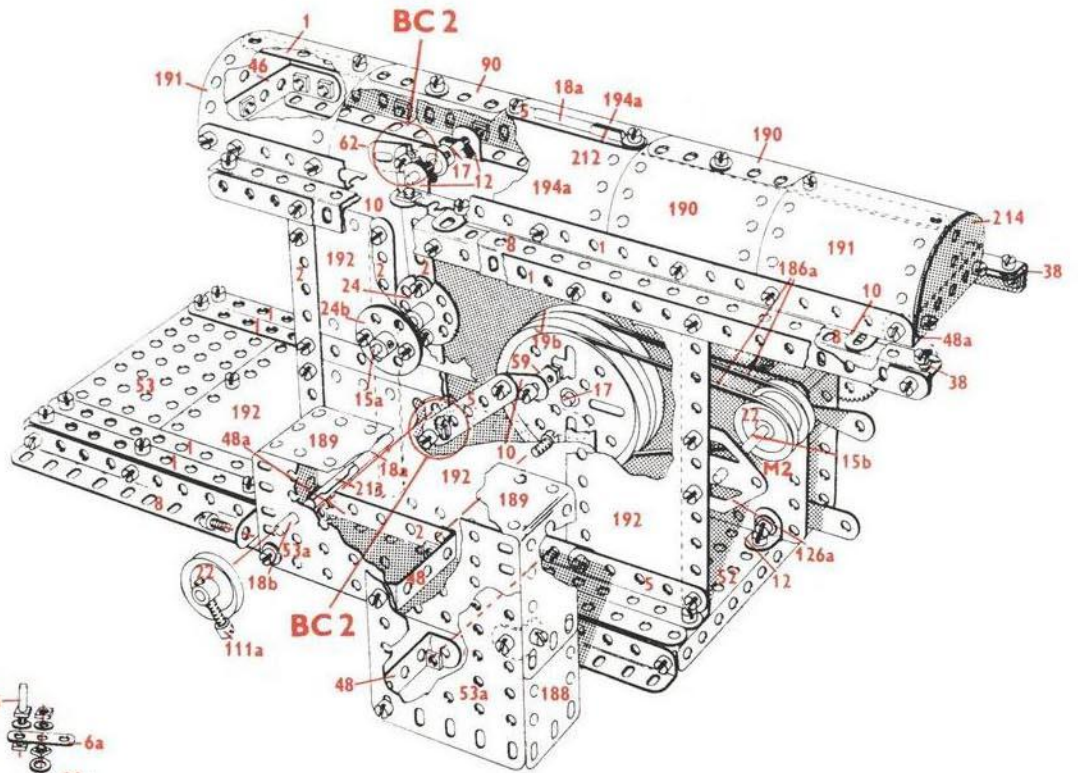
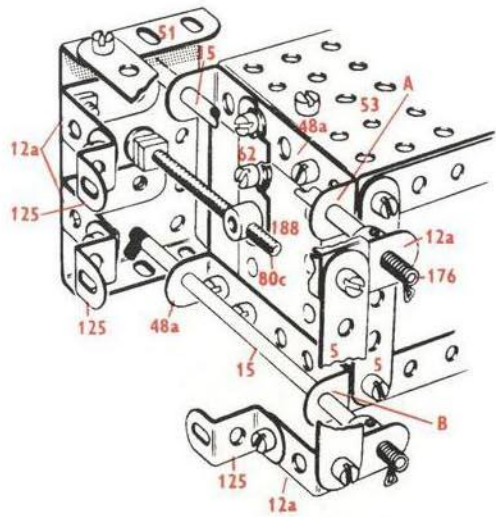

8.16 Avion cargo
 Cargo plane
 Vrachtvliegtuig
 Aero de carico
 Transportflugzeug
 Avion de carga

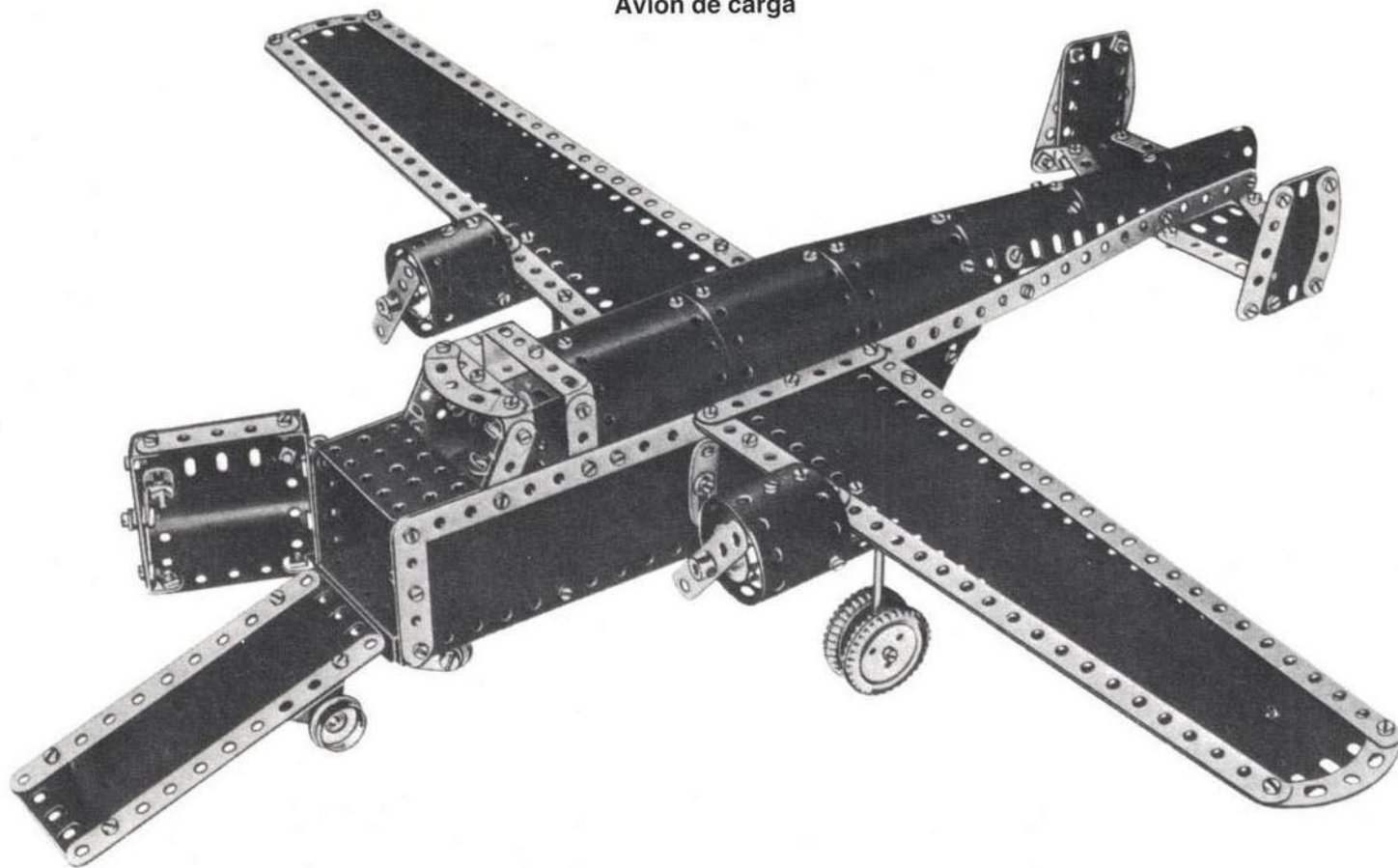

8.16

11 - 1	2 - 53a
2 - 2	4 - 59
2 - 3	2 - 62
2 - 4	1 - 63
12 - 5	2 - 90
4 - 6a	3 - 90a
5 - 10	2 - 111a
1 - 11	1 - 111c
1 - 11a	1 - 115
18 - 12	3 - 125
1 - 12a	2 - 126
1 - 12c	4 - 142c
2 - 16	1 - 147b
1 - 17	6 - 188
3 - 18a	2 - 189
1 - 18b	7 - 190
4 - 20b	1 - 191
2 - 22	6 - 192
2 - 22a	2 - 193
1 - 23	1 - 194a
2 - 24a	2 - 197
155 - 37a	2 - 212a
156 - 37b	2 - 214
20 - 38	4 - 215
2 - 48	4 - 221
6 - 48a	2 - 222
1 - 51	2 - 223
1 - 52	
3 - 53	

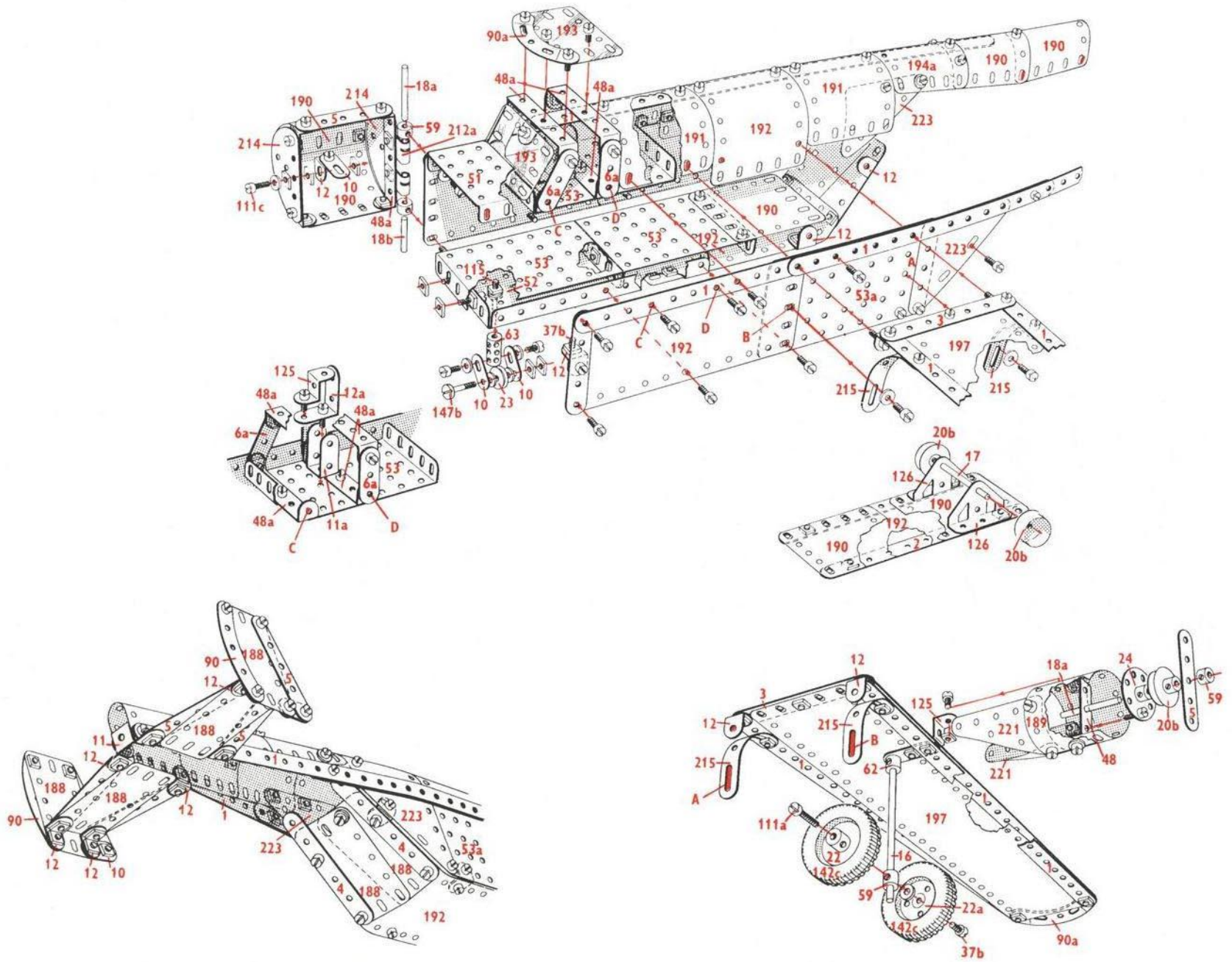

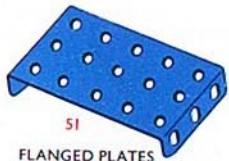

51
FLANGED PLATES
51 - 2½" × 1½"; 60 × 38 mm
52 - 5½" × 2½"; 14 × 6 cm
53 - 3½" × 2½"; 9 × 6 cm

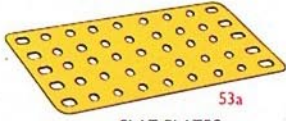

53a
FLAT PLATES
52a - 5½" × 3½"; 14 × 9 cm
53a - 4½" × 2½"; 11½ × 6 cm



54 - 4½"; 115 mm
FLANGED SECTOR PLATE



PERFORATED SLOTTED STRIP
55 - 5½"; 14 cm
55a - 2"; 5 cm



57b
HOOK



57c
HOOK



57d
WIRE HOOK



58 **SPRING CORD** - 40"; 1 metre



59
COLLAR WITH SCREW



58a
COUPLING SCREW FOR 58



58b
HOOK FOR 58



61
WINDMILL SAIL



62
62a **CRANK**
62b **THREADED CRANK**



62b **DOUBLE ARM CRANK**



63
COUPLING



63b **STRIP COUPLING**



63c
THREADED COUPLING



63d **SHORT COUPLING**



64
THREADED BOSS



65
CENTRE FORK



69
SET SCREW
69 3/8"; 4 mm

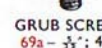

69a - 3/8"; 4 mm
69b - 1/2"; 5 mm
69c - 3/4"; 3 mm

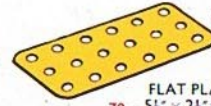

70 - 5½" × 2½"; 14 × 6 cm
72 - 2½" × 2½"; 6 × 6 cm
73 - 3" × 1½"; 75 × 38 mm
74 - 1½" × 1½"; 38 × 38 mm

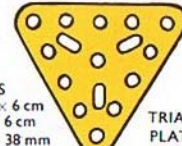

76 - 2½"; 6 cm
77 - 1"; 25 mm
TRIANGULAR PLATES



80a - 3½"; 9 cm
80b - 4½"; 11½ cm
80c - 3"; 7½ cm
80d - 2"; 5 cm
81 - 2"; 5 cm
82 - 1"; 25 mm
SCREWED RODS

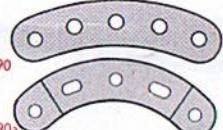

90
90a
CURVED STRIP
89 - 5½"; 14 cm
90 - 2½"; 6 cm



94 - 40";
1 metre
SPROCKET CHAIN



95 - 2"; 5 cm
95a - 1½"; 38 mm
95b - 3"; 75 mm
96 - 1"; 25 mm
96a - ¾"; 19 mm
SPROCKET WHEELS

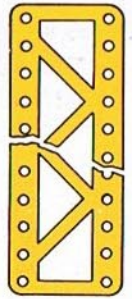

97 - 3½"; 9 cm
99 - 1½"; 32 cm
99a - 9½"; 24 cm
99b - 7½"; 19 cm
100 - 5½"; 14 cm
BRACED GIRDERS



102
SINGLE BENT STRIP

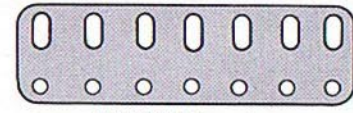

103 - 5½"; 14 cm
103a - 9½"; 24 cm
103b - 12½"; 32 cm
103c - 4½"; 11½ cm
103d - 3½"; 9 cm
103e - 3"; 7½ cm
103f - 2½"; 6 cm
103g - 2"; 5 cm
103h - 1½"; 38 mm
103k - 7½"; 19 cm
FLAT GIRDERS

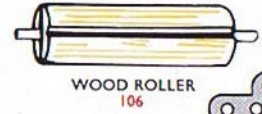

106
WOOD ROLLER

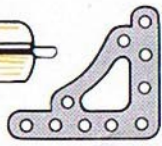

108
CORNER GUSSET



109 - 2½"; 6 cm
FACE PLATE



110 - 3½"; 9 cm
110a - 6½"; 16½ cm
RACK STRIPS

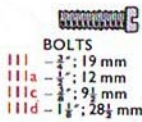

111 - 2"; 19 mm
111a - 1"; 12 mm
111c - ¾"; 9 mm
111d - 1½"; 28½ mm
BOLTS

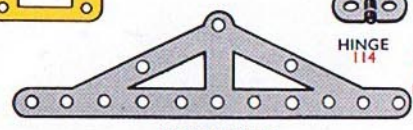

113
GIRDER FRAME



114
HINGE



115 - 1"; 15 mm
115a long. 1½"; 34 mm
THREADED PINS



116
FORK PIECE LARGE



116a
FORK PIECE SMALL



118 - 5½"; 14 cm
HUB DISC



120b - 7/8"; 14 mm
COMPRESSION SPRING



122
LOADED SACK



123 - 1½" × 1" × ¾";
32 × 25 × 19 mm
CONE PULLEY



124
REVERSED ANGLE BRACKETS
1"; 25 mm
¾"; 12 mm



126
TRUNNION



126a
FLAT TRUNNION



128
BELL CRANK



130 - 1" × ¾" × ¾";
6 × 9 × 12 mm
ECCENTRIC TRIPLE THROW



130a - 1"; 6 mm
ECCENTRIC SINGLE THROW



131
CAM

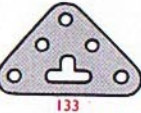

133
CORNER BRACKETS
- 1½"; 38 mm



133a
CORNER BRACKETS
- 1"; 25 mm



134 - 1"; 25 mm
CRANK SHAFT



136
HANDRAIL SUPPORT



136a
HANDRAIL COUPLING



137
WHEEL FLANGE



138
SHIP'S FUNNEL



139 (right)
139a (left)
FLANGED BRACKET



140
UNIVERSAL COUPLING



142a - 2"; 5 cm
142b - 3"; 7½ cm
142c - 1"; 25 mm
142d - 1½"; 38 mm
MOTOR TYRES



143 - 5½"; 14 cm
CIRCULAR GIRDER



144
DOG CLUTCH



145 - 7½"; 19 cm
CIRCULAR STRIP

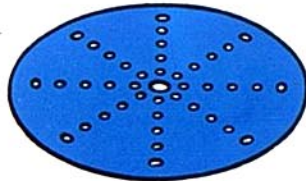

CIRCULAR PLATES
146a - 4"; 10 cm
146 - 6"; 15 cm



PAWL WITH PIVOT BOLT & NUTS
147



PAWL
147a



PIVOT BOLT
147b



147c PAWL WITHOUT BOSS



RATCHET WHEEL
148



PULLEY BLOCKS
153 TRIPLE
151 SINGLE



CORNER ANGLE BRACKET
154a - 1/2"; 12 mm (right)
154b - 1/2"; 12 mm (left)



FLEXIBLE RING
155 - 1"; 25 mm



FAN
157 - 2"; 5 cm



CHANNEL BEARING
160 - 1 1/2" x 1" x 1/2";
38 x 25 x 12 mm



GIRDER BRACKET
161 - 2" x 1" x 1/2";
50 x 25 x 12 mm

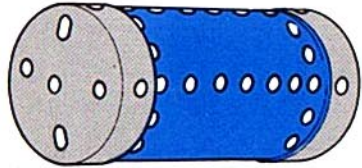

162 BOILER COMPLETE - 5" x 2 1/4"; 12 1/2 x 5 cm
162a BOILER END - 2 1/4" x 2"; 50 x 19 mm



SLEEVE PIECE
163 - 1 1/2" x 1 1/4";
38 x 17 mm



CHIMNEY ADAPTOR
164 - 3/4" x 1/2";
16 x 12 mm



SWIVEL BEARING
165



END BEARING
166



LARGE TOOTHED QUADRANT PINION
167c

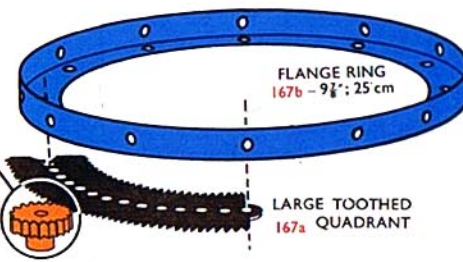

FLANGE RING
167b - 9 1/2"; 25 cm

LARGE TOOTHED QUADRANT
167a



168 BALL THRUST BEARING COMPLETE - 4"; 10 cm
168a AND 168b BALL THRUST RACES
168c BALL CAGE



168d BALL
3/8"; 9 1/2 mm



173a ADAPTOR FOR SCREWED ROD



171 SOCKET COUPLING



176 ANCHORING SPRING



175 FLEXIBLE COUPLING UNIT



179 ROD SOCKET



GEAR RING
180 - 3 1/2"; 9 cm



STEERING WHEELS
185 - 1 1/2"; 4 1/2 cm
185a - 2 1/2"; 60 mm



DRIVING BANDS
light
186 - 2 1/2"; 6 cm
186a - 6"; 15 cm
186b - 10"; 25 cm
heavy
186c - 10"; 25 cm
186d - 15"; 37 1/2 cm
186e - 20"; 50 cm



ROAD WHEELS
187 - 2 1/2"; 60 mm



CONICAL DISC
187a - 1 1/2"; 47 mm

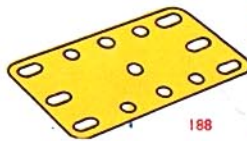

FLEXIBLE PLATES
188 - 2 1/2" x 1 1/2"; 60 x 38 mm
189 - 5 1/2" x 1 1/2"; 140 x 38 mm
190 - 2 1/2" x 2 1/2"; 6 x 6 cm
190a - 3 1/2" x 2 1/2"; 9 x 6 cm
191 - 4 1/2" x 2 1/2"; 11 1/2 x 6 cm
192 - 5 1/2" x 2 1/2"; 14 x 6 cm

TRANSPARENT PLATES
193 - 2 1/2" x 1 1/2"; 60 x 38 mm
193a - 2 1/2" x 2 1/2"; 60 x 60 mm

BLUE PLASTIC PLATES
194 - 2 1/2" x 1 1/2"; 60 x 38 mm
194a - 2 1/2" x 2 1/2"; 60 x 60 mm
194b - 3 1/2" x 2 1/2"; 90 x 60 mm
194c - 4 1/2" x 2 1/2"; 115 x 60 mm
194d - 5 1/2" x 1 1/2"; 140 x 38 mm
194e - 5 1/2" x 2 1/2"; 140 x 60 mm

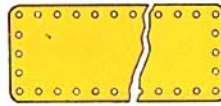

STRIP PLATES
195 - 7 1/2" x 2 1/2"; 19 x 6 cm
196 - 9 1/2" x 2 1/2"; 24 x 6 cm
197 - 12 1/2" x 2 1/2"; 32 x 6 cm

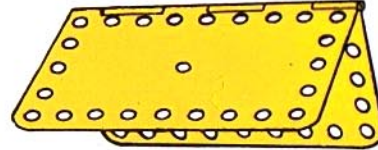

HINGED FLAT PLATE
198 - 4 1/2" x 2 1/2"; 11 1/2 x 6 cm

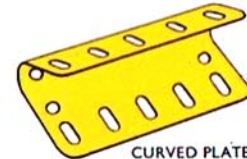

CURVED PLATE U SECTION
199 - 2 1/2" x 2 1/2" x 3/8";
60 x 60 x 7 mm

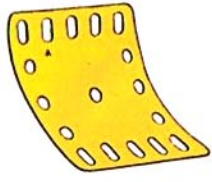

CURVED PLATE
200 - 2 1/2" x 2 1/2" x 1 1/2";
60 x 60 x 43 mm

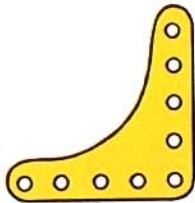

FLEXIBLE GUSSET PLATE
201 - 2 1/2" x 2 1/2";
60 x 60 mm



HELICAL GEARS
211a - 1/2"; 12 mm
211b - 1 1/2"; 38 mm
can only be used together.



212 ROD AND STRIP CONNECTOR

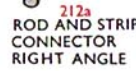

212a ROD AND STRIP CONNECTOR RIGHT ANGLE



213 ROD CONNECTORS



SEMI-CIRCULAR PLATE
214 - 2 1/2"; 6 cm

FORMED SLOTTED STRIP
215 - 3"; 7 1/2 cm

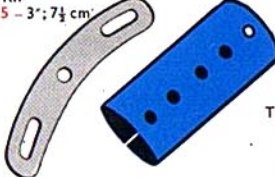

CYLINDER
216 - 2 1/2" x 1 1/2";
60 x 30 mm

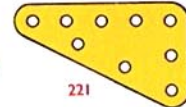

TRIANGULAR FLEXIBLE PLATES
221 - 2 1/2" x 1 1/2"; 60 x 38 mm
222 - 2 1/2" x 2"; 60 x 50 mm
223 - 2 1/2" x 2 1/2"; 60 x 60 mm
224 - 3 1/2" x 1 1/2"; 90 x 38 mm
225 - 3 1/2" x 2"; 90 x 50 mm
226 - 3 1/2" x 2 1/2"; 90 x 60 mm



223 KEY BOLT
231



ROD WITH KEYWAY
230 - 4"; 10 cm



NARROW STRIPS
235 - 2 1/2" x 1 1/2"; 60 mm x 9 mm
235a - 3" x 1 1/2"; 75 mm x 9 mm
235b - 3 1/2" x 1 1/2"; 90 mm x 9 mm
235d - 4 1/2" x 1 1/2"; 115 mm x 9 mm
235f - 5 1/2" x 1 1/2"; 140 mm x 9 mm