

9.1 Fire Escape

This Meccano model of a Fire Escape is typical of those used by fire brigades in most major cities throughout the world. As buildings grow higher the need for equipment of this kind becomes imperative, and it is common to find fire escape vehicles equipped with escapes capable of extending to over 100 ft. Integral with the extending ladder is a hose and adjustable nozzle, from which firemen can direct jets of water into places which would otherwise be inaccessible.

In the Meccano model Fire Escape illustrated here, the ladder extends to a working height of over 3 ft. It is mounted on a ball-bearing turntable which can be swivelled by means of crank-operated worm drive through 360 degrees. The elevation of the escape is similarly crank-operated and the ladder is extended and retracted by means of a pulley system. Steadying jacks are provided at the rear of the chassis to give stability when the escape is in operation.

In the model the spacious cab, which in an actual vehicle houses both the driver and crew, is glazed at both front and sides.

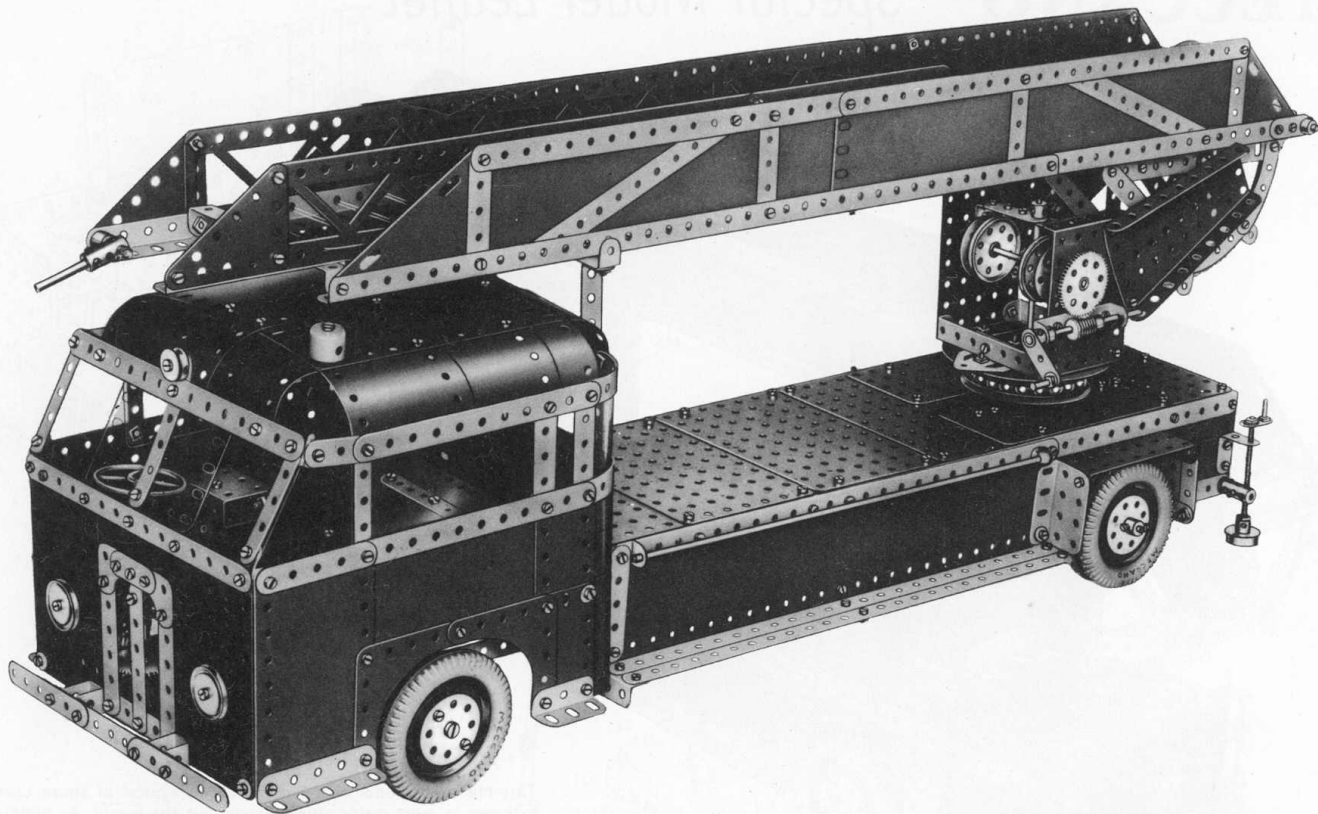

How to use this leaflet

The constructional details of the model shown in this Leaflet are explained entirely by means of half-tone illustrations and line drawings. Once the 'knack' of reading the drawings has been acquired assembly of the model will be found quite straightforward and simple to carry out.

Before starting to build the model it is advisable to study all the illustrations carefully so as to get a good idea of its various sections. Points at which various units of the model are bolted together to form the complete structure are indicated in the drawings by RED DOTS or RED BOLTHEADS whenever possible.

The particular parts used in the assembly of the model can in most cases

be identified simply by looking at the illustrations, but where the identity of a part may not be quite clear, its Part Number is printed on the model illustrations in RED. RED DOTTED pointer lines are used to indicate parts that are hidden behind other parts of the structure.

As a further help a list of the parts required to build the model is given in this Leaflet. In this list the catalogue numbers of the parts are printed in RED and the quantity of each part in BLACK.

In models fitted with a driving Motor the particular type of Motor is indicated by one of the following Code Marks: M1 = Magic Clockwork Motor; M2 = No. 1 Clockwork Motor; M3 = Meccano Electric Motor.

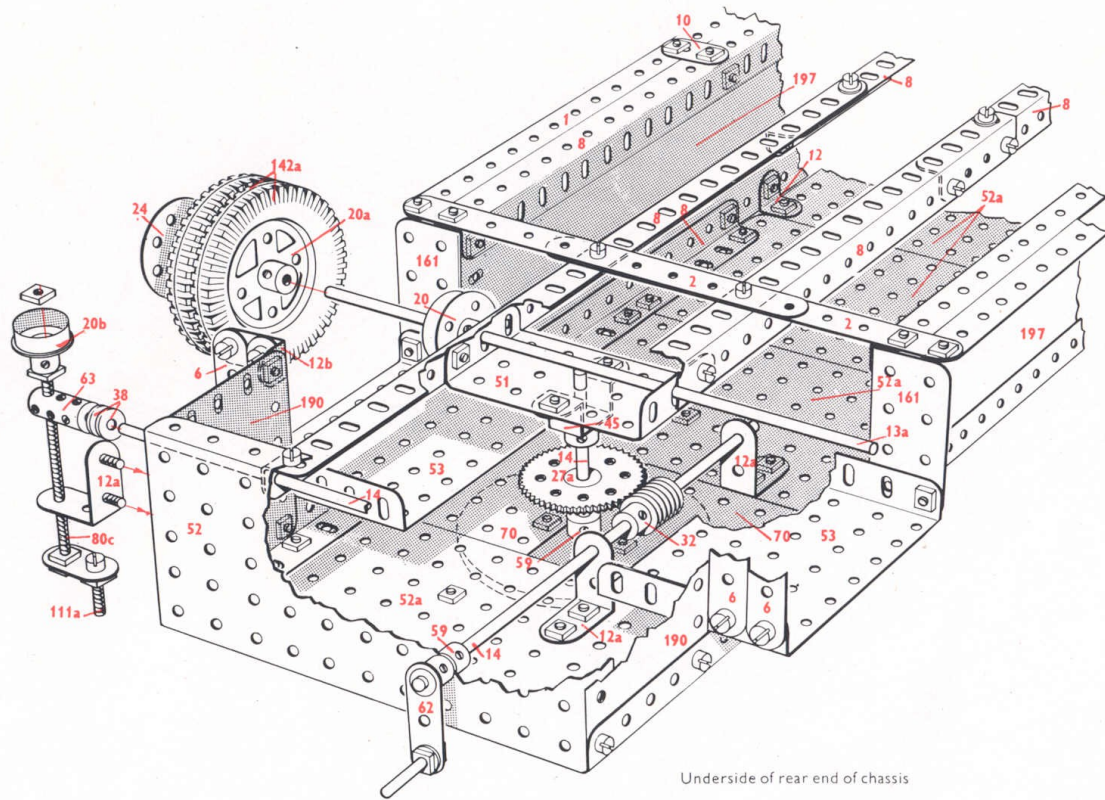

Underside of rear end of chassis

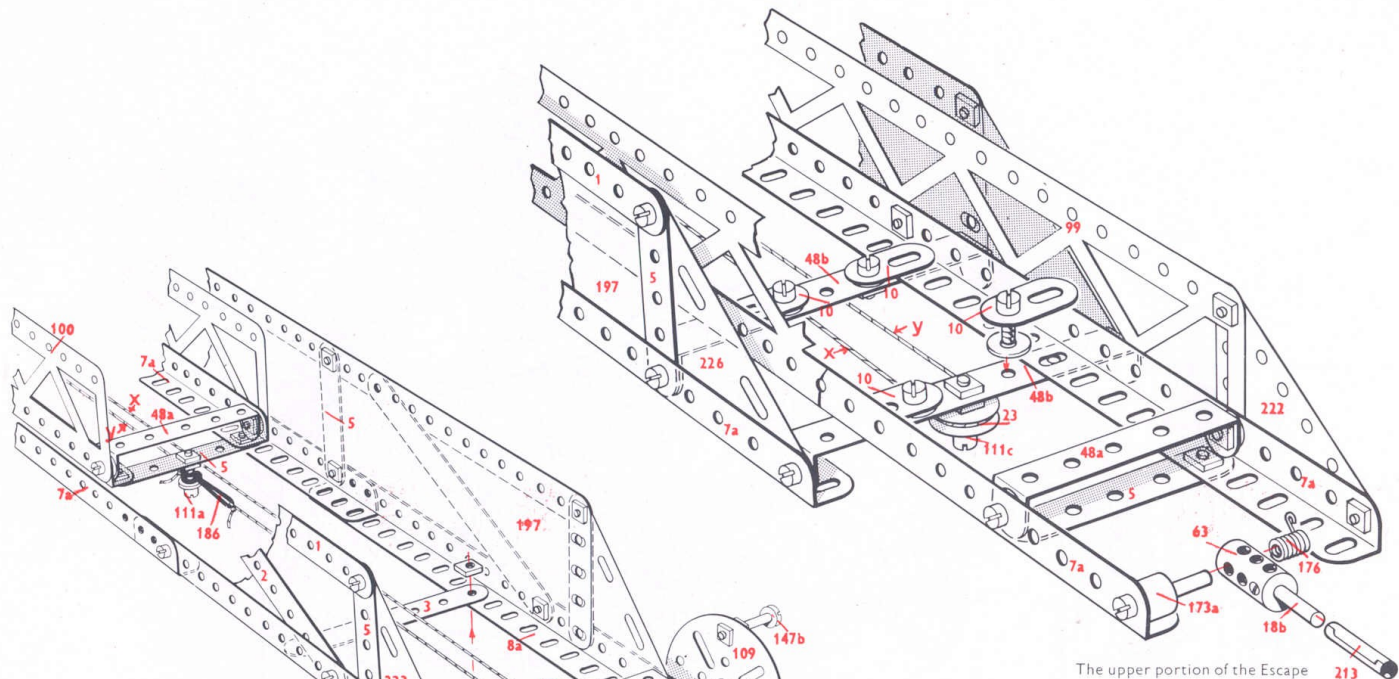

The upper portion of the Escape 213

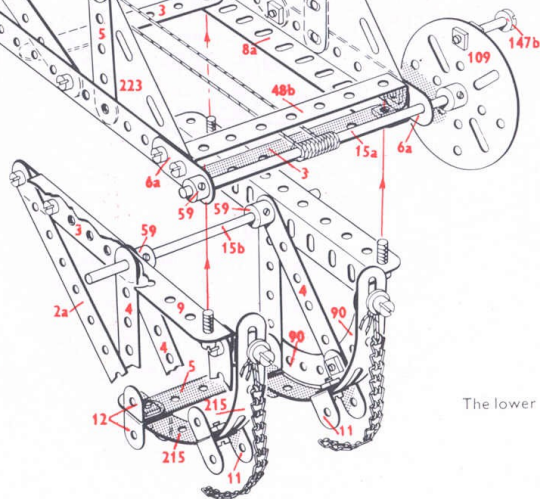

The lower portion of the fixed ladder

9.2 Wharf Crane

Dockland provides many fascinating subjects for the Meccano builder and chief among these are the numerous types of crane, large and small, to be seen in any up-to-date and well-equipped port. One of these cranes forms the prototype of the attractive model illustrated with detail constructional plans in this Leaflet. This is one of several types of Wharf Crane, a feature of which is its long slender jib pivoted to a swivelling superstructure mounted on a tall tower. The radius of operation of this particular type of crane is relatively small but, on the other hand, bulky and heavy loads can be raised and lowered through a considerable vertical distance. This is particularly necessary in loading and unloading large ocean-going vessels at quaysides, where it is necessary to be able to clear the hull and superstructure of the ship, which itself may be rising and falling through as much as 20 ft., according to the state of the tide. Such Wharf Cranes are usually of the travelling type and run on rails laid along the quay or wharf side.

In this Meccano model Wharf Crane the power for operating the load-hoisting mechanism is provided by an Meccano E15R Electric Motor housed with the load-hoisting and jib-elevating mechanism in the operator's cab. The cabin itself is mounted on ball bearings and slewing is carried out manually by a simple system of gearing from a handwheel located at the top of the tower structure.

How to use this leaflet

The constructional details of the model shown in this Leaflet are explained entirely by means of half-tone illustrations and line drawings. Once the 'knack' of reading the drawings has been acquired assembly of the model will be found quite straightforward and simple to carry out.

Before starting to build the model it is advisable to study all the illustrations carefully so as to get a good idea of its various sections. Points at which various units of the model are bolted together to form the complete structure are indicated in the drawings by RED DOTS or RED BOLTHEADS whenever possible.

The particular parts used in the assembly of the model can in most cases be identified simply by looking at the illustrations, but where the identity of a part may not be quite clear, its Part Number is printed on the model illustrations in RED. RED DOTTED pointer lines are used to indicate parts that are hidden behind other parts of the structure.

As a further help a list of the parts required to build the model is given in this Leaflet. In this list the catalogue numbers of the parts are printed in RED and the quantity of each part in BLACK.

In models fitted with a driving Motor the particular type of Motor is indicated by one of the following Code Marks: M1 = Magic Clockwork Motor; M2 = No. 1 Clockwork Motor; M3 = Meccano Electric Motor.



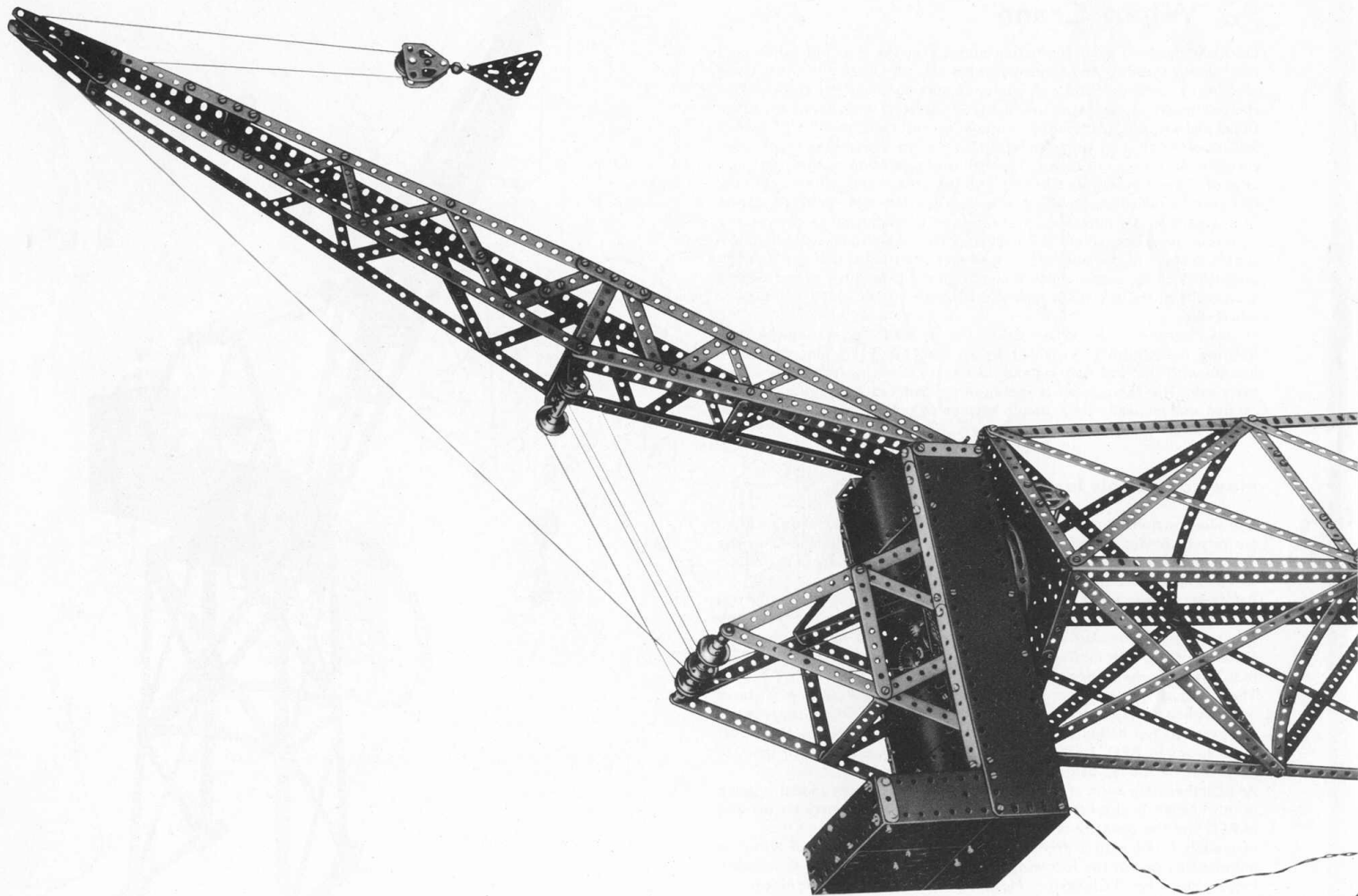

One of the four wheels on which the Crane travels

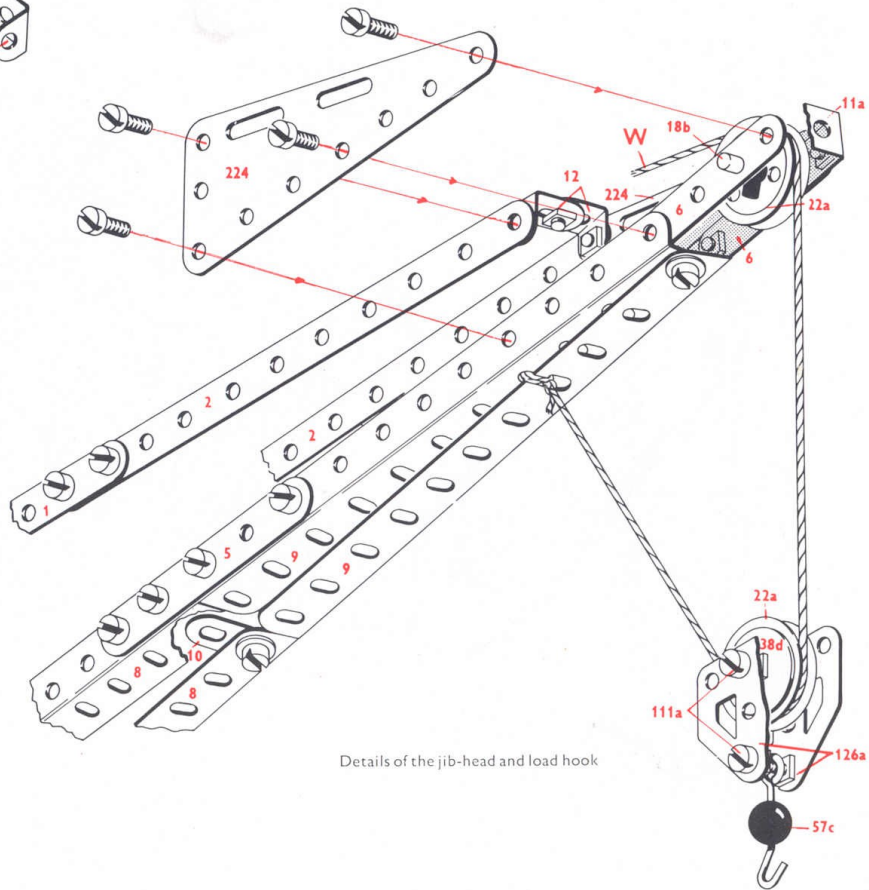
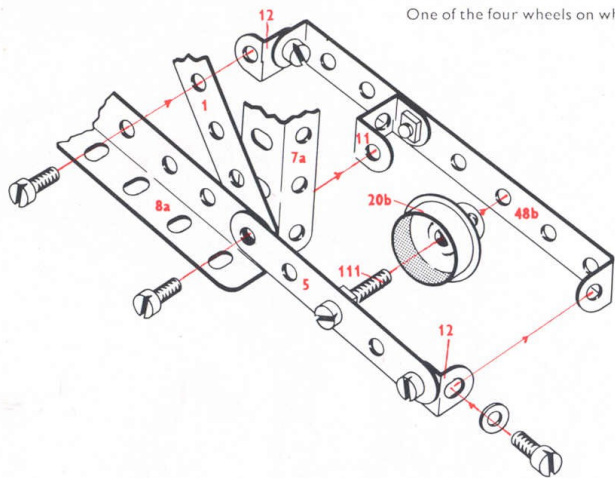

Details of the jib-head and load hook

14	-	1	2	-	51
4	-	1b	2	-	52
23	-	2	4	-	52a
6	-	2a	4	-	53
6	-	3	2	-	53a
7	-	4	2	-	54
23	-	5	1	-	57c
4	-	6	9	-	59
5	-	6a	2	-	62
4	-	7a	6	-	63
8	-	8	2	-	70
2	-	8a	4	-	89
4	-	9	1	-	94
2	-	9d	1	-	95
3	-	10	1	-	96
4	-	11	1	-	109
1	-	11a	5	-	111
29	-	12	6	-	111a
2	-	12a	3	-	111c
1	-	13a	2	-	120b
1	-	15a	2	-	126
2	-	15b	4	-	126a
4	-	16	2	-	133a
2	-	17	2	-	136
4	-	18a	1	-	137
2	-	18b	1	-	143
2	-	19b	1	-	146a
2	-	20	1	-	147b
4	-	20b	2	-	155
5	-	22	2	-	161
4	-	22a	1	-	163
1	-	23a	2	-	164
2	-	24	1	-	165
1	-	25	21	-	168d
2	-	26	2	-	179
2	-	27a	2	-	186
1	-	28	6	-	188
1	-	32	3	-	189
2	-	35	3	-	190
297	-	37a	4	-	191
288	-	37b	2	-	192
28	-	38	1	-	197
2	-	40	2	-	212
2	-	45	4	-	214
1	-	46	4	-	215
2	-	48	6	-	235
4	-	48b	2	-	235a
2	-	48c			

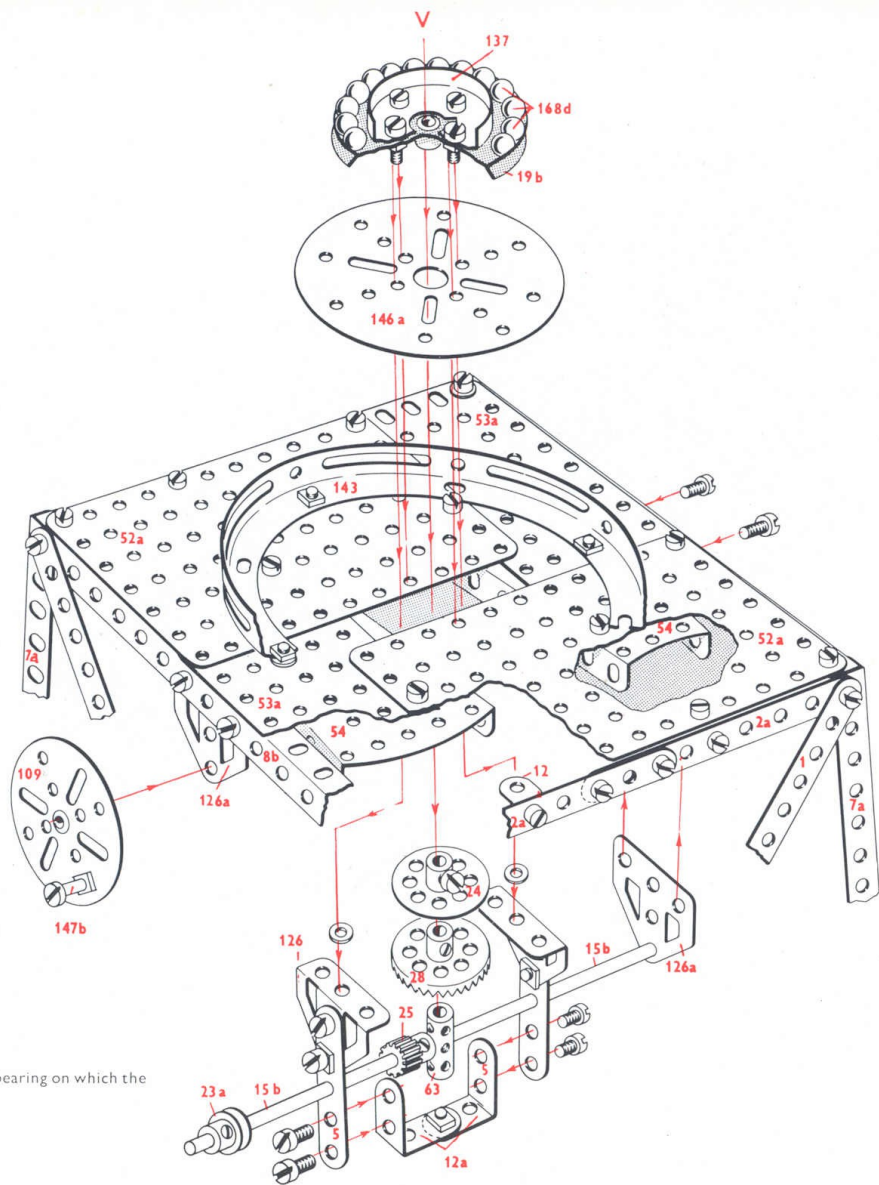

The top of the tower showing the ball bearing on which the superstructure swivels

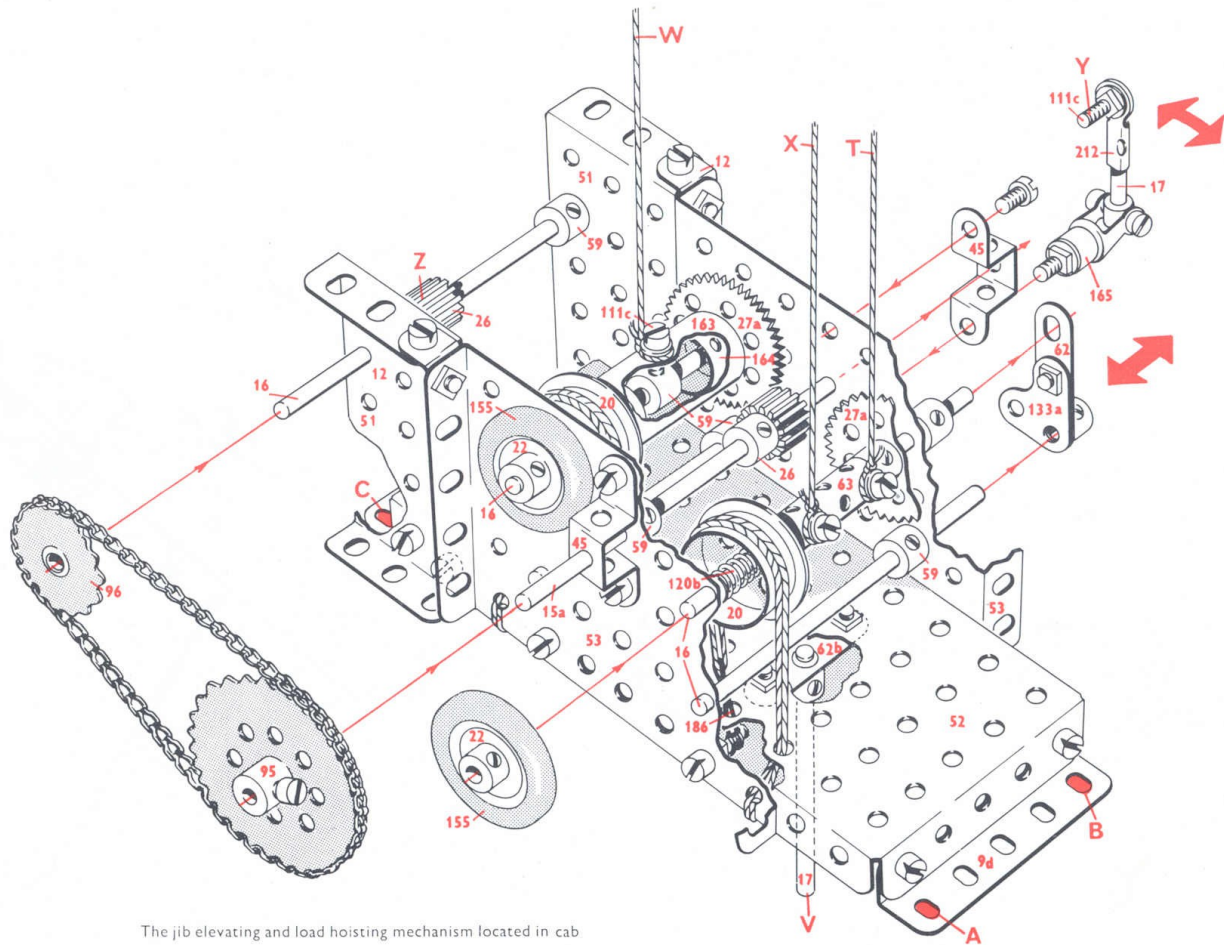

The jib elevating and load hoisting mechanism located in cab

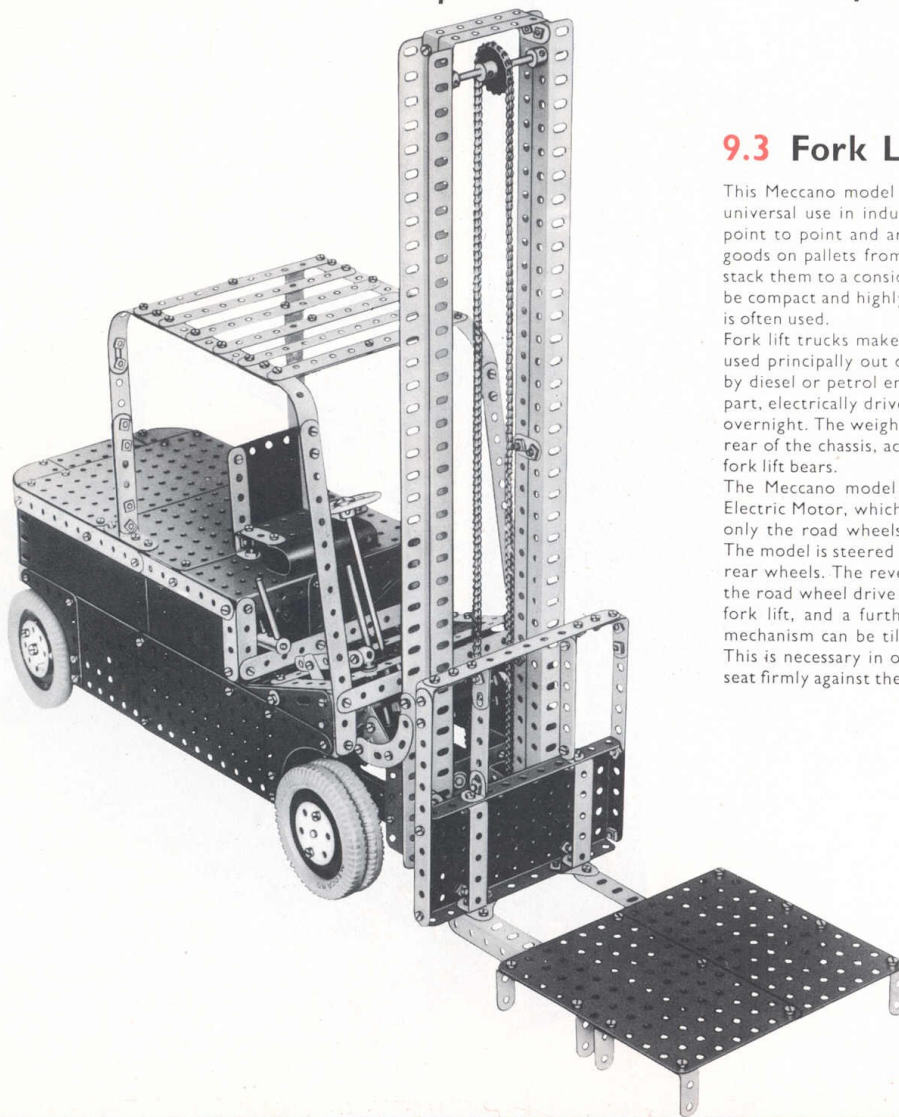

9.3 Fork Lift Truck

This Meccano model of a Fork Lift Truck typifies vehicles which are in universal use in industry. They are designed to move bulky loads from point to point and are particularly useful because of their ability to lift goods on pallets from the ground, carry them to store and then lift and stack them to a considerable height in the warehouse. Such vehicles must be compact and highly manoeuvrable, and to aid this, rear wheel steering is often used.

Fork lift trucks make use of a number of different power sources. Those used principally out of doors or in unconfined spaces are often powered by diesel or petrol engines. Those used inside factories are, for the most part, electrically driven from high-capacity batteries, which are recharged overnight. The weight of such batteries, which are usually disposed at the rear of the chassis, acts as a counterbalance to the heavy loads which the fork lift bears.

The Meccano model Fork Lift Truck is powered by a Meccano E15R Electric Motor, which drives through a system of clutches and gearing not only the road wheels but also the elevating mechanism of the fork lift. The model is steered by a mechanical linkage from steering column to the rear wheels. The reversing mechanism for the Motor is common both to the road wheel drive and to the elevating and lowering mechanism of the fork lift, and a further mechanical linkage is arranged so that the lift mechanism can be tilted backwards through an arc of some 15 degrees. This is necessary in order that loads once positioned on the fork should seat firmly against the back plate when in transit.

2	-	1b	2	-	53
17	-	2	2	-	53a
5	-	2a	1	-	55a
2	-	3	11	-	59
8	-	4	2	-	62
31	-	5	1	-	62b
4	-	6	6	-	63
6	-	6a	2	-	70
4	-	7a	2	-	77
6	-	8	1	-	79a
4	-	9	4	-	90
2	-	9d	4	-	90a
2	-	9f	1	-	94
15	-	10	2	-	96
3	-	11	6	-	111
29	-	12	6	-	111c
4	-	12a	2	-	115
2	-	12b	1	-	115a
1	-	13a	1	-	116a
3	-	14	1	-	126
2	-	15	4	-	126a
4	-	15a	1	-	128
3	-	16	2	-	133a
3	-	16a	2	-	136
1	-	17	6	-	142a
3	-	18a	2	-	147b
2	-	18b	1	-	154a
6	-	20a	2	-	161
2	-	20b	2	-	165
1	-	23	1	-	166
1	-	23a	2	-	179
2	-	24	1	-	185
2	-	24a	2	-	188
2	-	24c	1	-	189
1	-	25	2	-	190
5	-	26	3	-	191
1	-	27	2	-	192
2	-	27a	1	-	193d
1	-	28	2	-	193e
2	-	32	1	-	199
286	-	37a	2	-	200
262	-	37b	4	-	201
26	-	38	2	-	212
2	-	38d	2	-	214
1	-	45	6	-	215
1	-	46	2	-	222
6	-	48a	2	-	224
2	-	52	2	-	225
2	-	52a	3	-	235

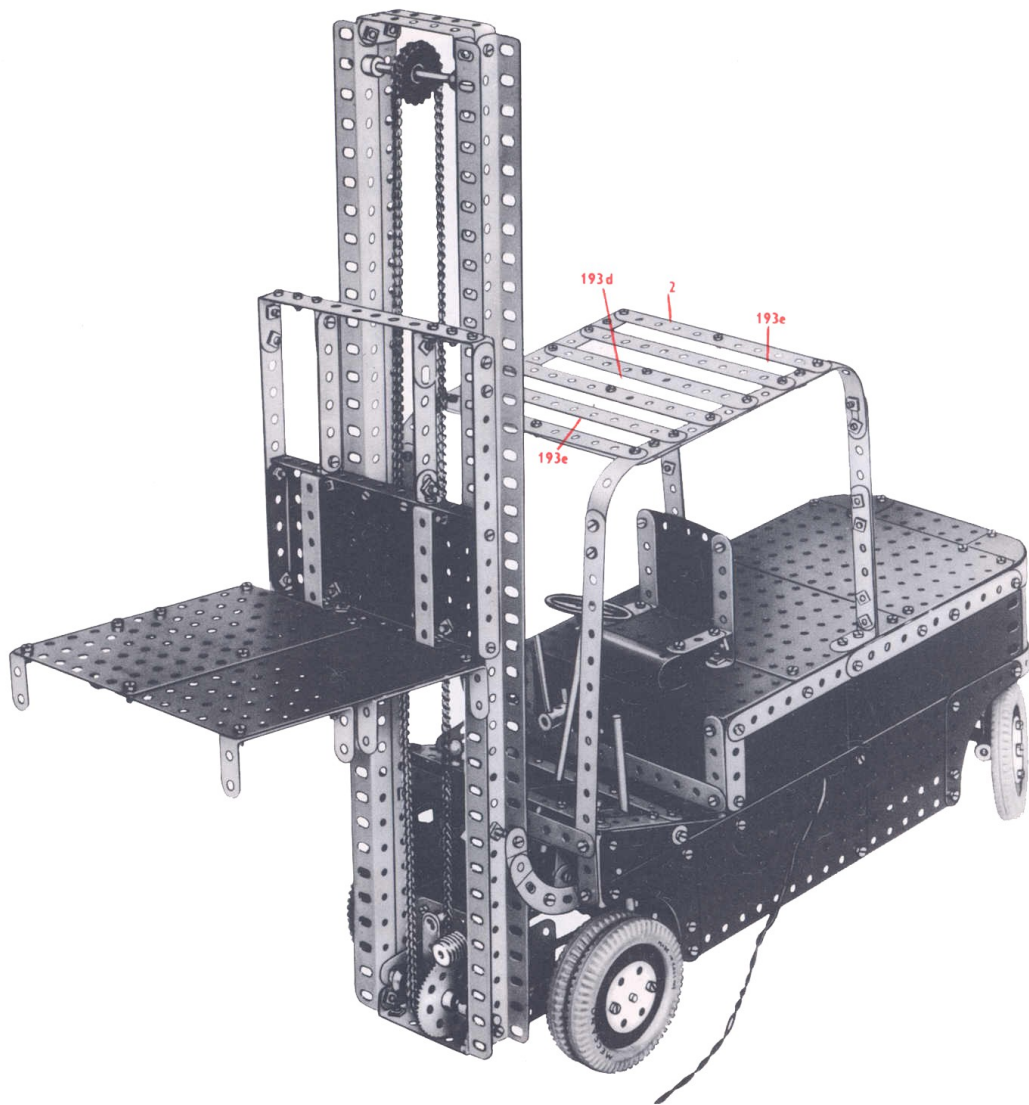

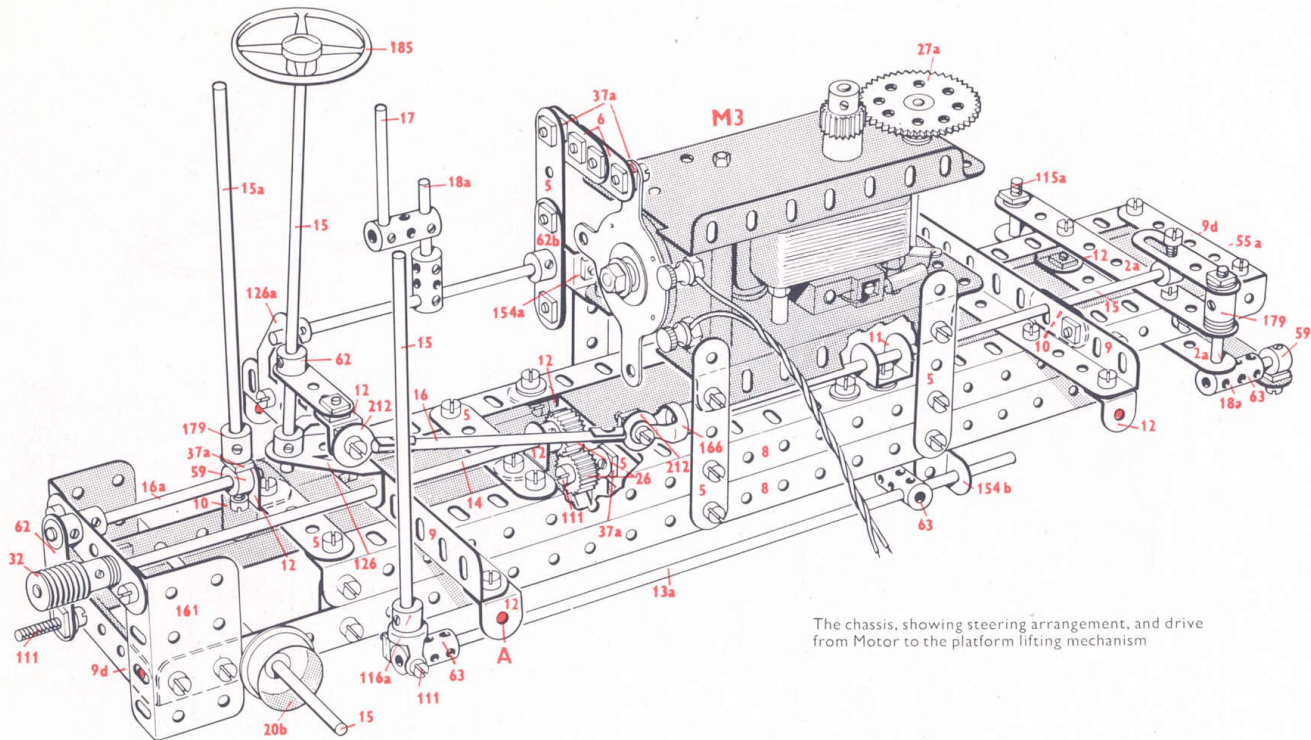

Underside of the chassis, showing the Motor drive to the travelling wheels

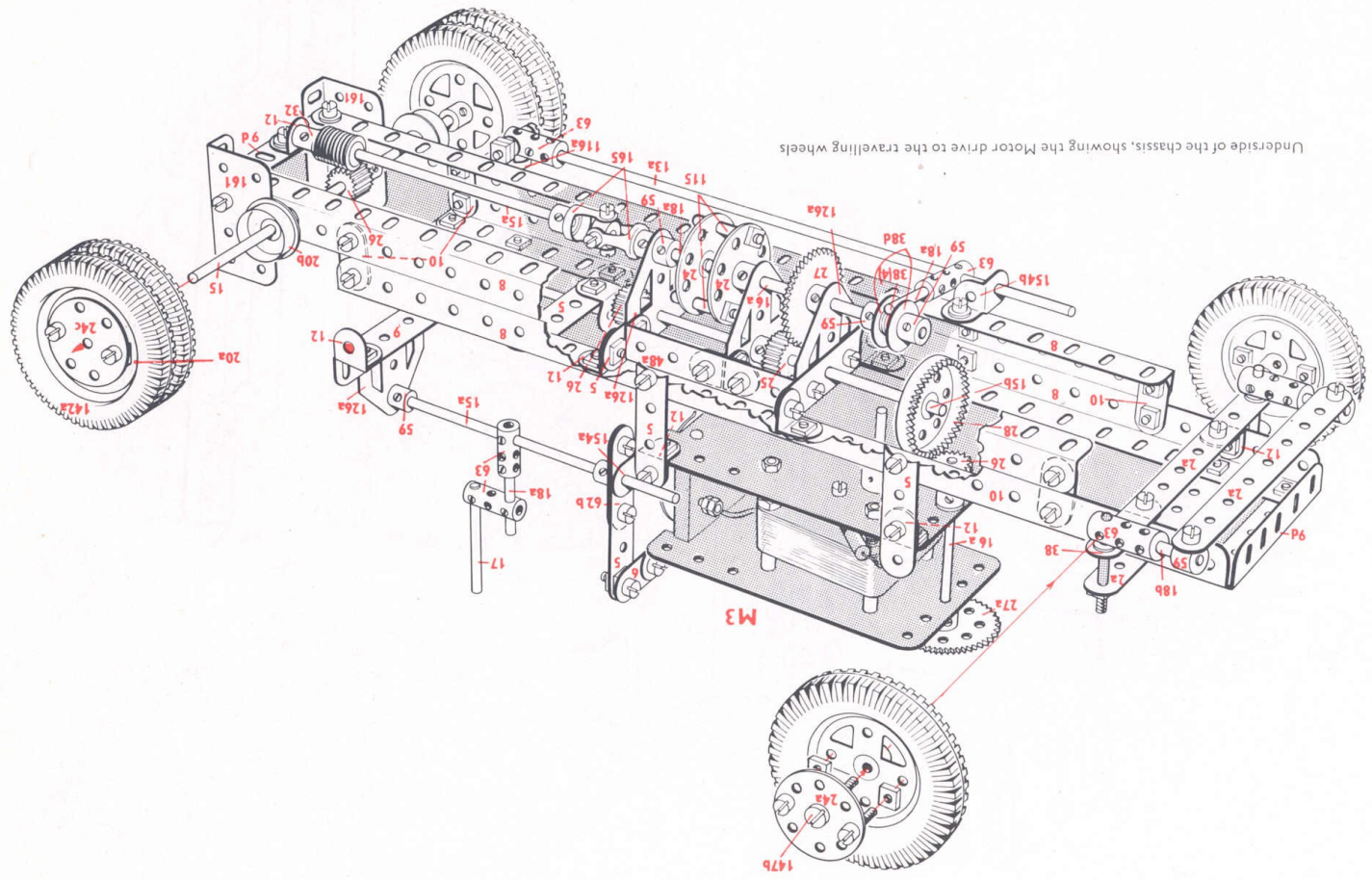

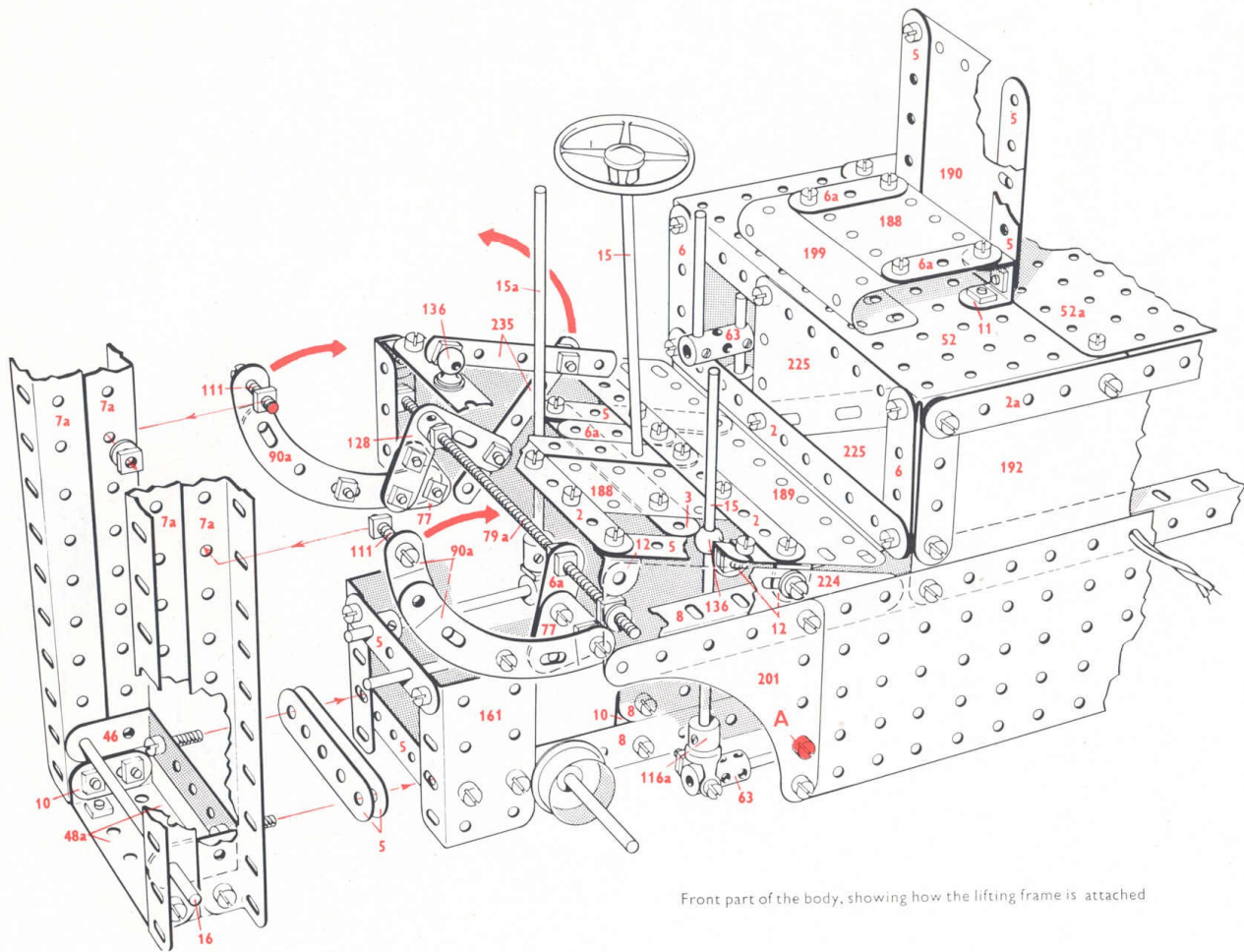

Front part of the body, showing how the lifting frame is attached

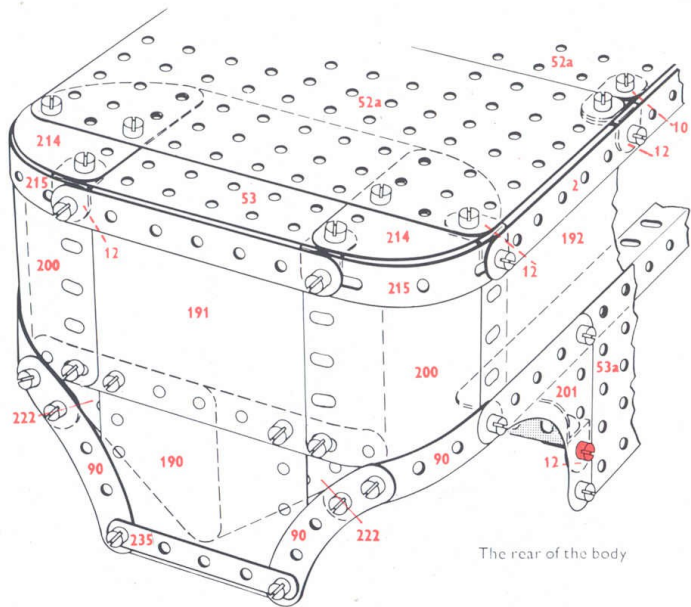
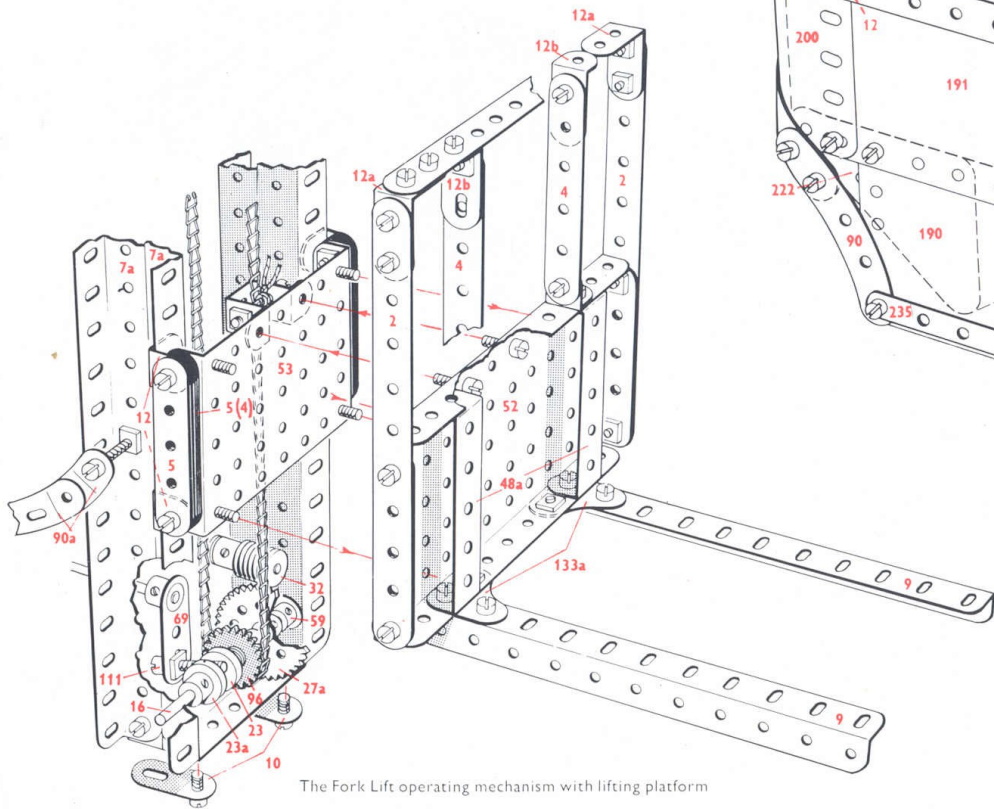

9.4 Giant Walking Dragline Excavator

The Giant Dragline Excavator illustrated with constructional plans in this Leaflet, is based on actual machines used for massive excavation operations such as are required in the making of canals and railway cuttings, and for work in clay pits and clearing overburden in open-cast mining. The name 'dragline' is derived from the fact that the digging bucket is dragged towards the machine on a flexible rope, instead of being mounted on a pivoted arm fixed to a jib as in the case of mechanical shovels. Owing to this action it is possible to place a dragline some distance away from the scene of the actual operations, and due to this feature a dragline is of exceptional value in locations where the ground is too soft to allow an ordinary mechanical shovel with short jib to stand.

Some draglines are mounted with creeper tracks while others move from place to place on giant feet that are operated by powerful machinery to give a 'walking' motion.

The model illustrated here is based on a machine of this kind and is powered by an E15R Electric Motor.



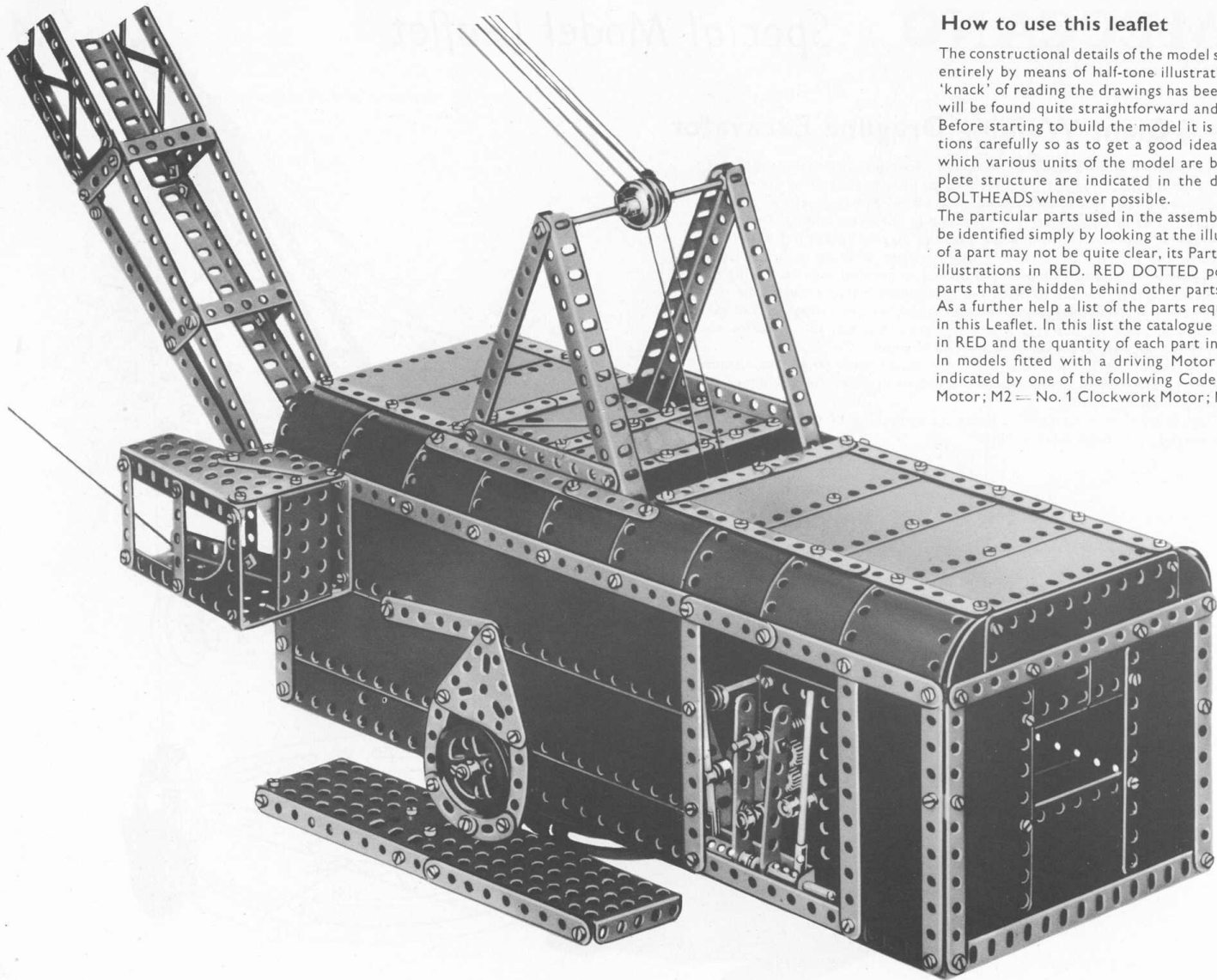

How to use this leaflet

The constructional details of the model shown in this leaflet are explained entirely by means of half-tone illustrations and line drawings. The 'knack' of reading the drawings has been acquired by practice and will be found quite straightforward and simple to learn. Before starting to build the model it is advisable to read the instructions carefully so as to get a good idea of its various parts. The parts which various units of the model are bolted together are indicated in the drawings by BOLT HEADS whenever possible.

The particular parts used in the assembly of the model are identified simply by looking at the illustrations. If the number of a part may not be quite clear, its Part Number is indicated in the illustrations in RED. RED DOTTED pointer lines indicate parts that are hidden behind other parts of the structure. As a further help a list of the parts required to build the model is given in this Leaflet. In this list the catalogue numbers of the parts are in RED and the quantity of each part in BLACK. In models fitted with a driving Motor the particular Motor is indicated by one of the following Code Marks: M1 = No. 1 Motor; M2 = No. 1 Clockwork Motor; M3 = Meccano Motor.

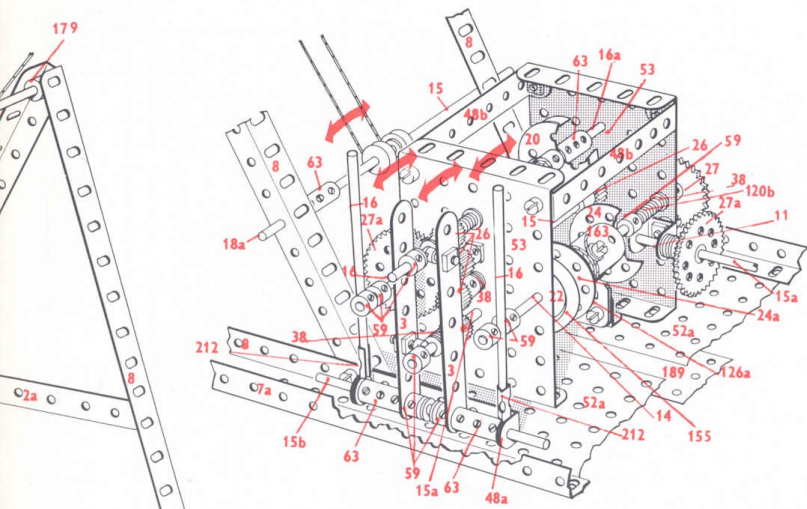

The winding mechanism assembled, with control levers

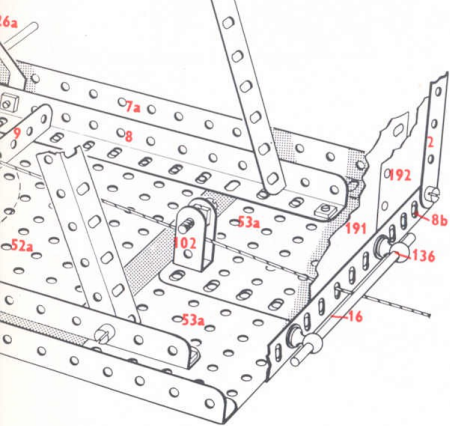

Diagrammatic layout of the winding mechanism for the boom and digging bucket

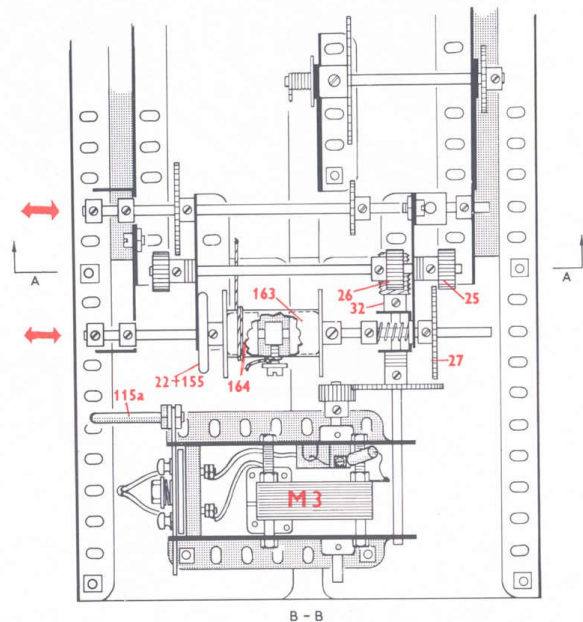

B - B

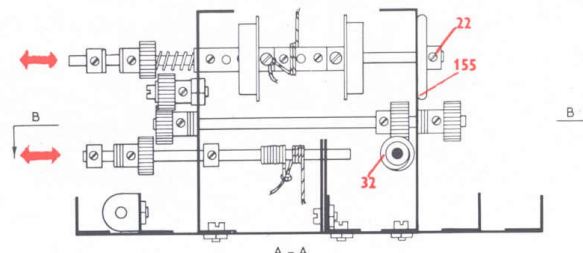

A - A

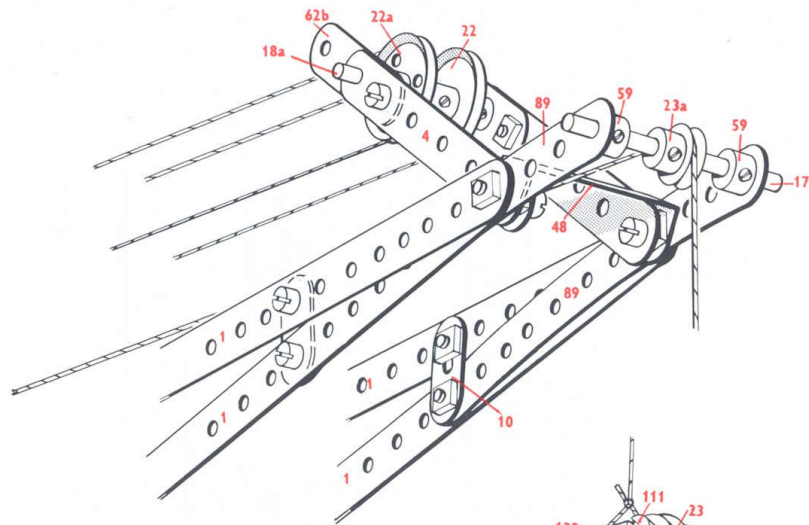

The jib-head and pulley assembly

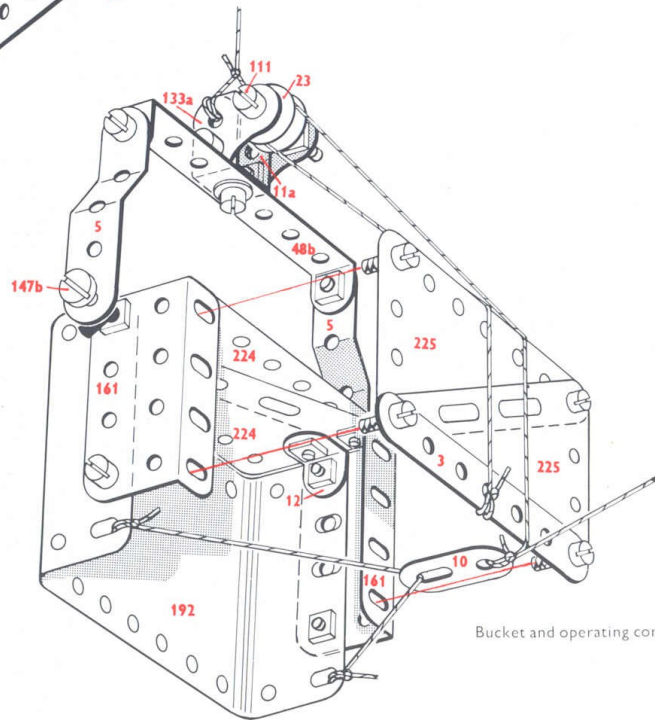

Bucket and operating cords

9.4

14	-	1	2	-	27a	3	-	111a
2	-	1b	1	-	32	10	-	111c
24	-	2	4	-	35	1	-	115a
6	-	2a	329	-	37a	2	-	120b
5	-	3	299	-	37b	6	-	126a
8	-	4	31	-	38	2	-	133a
13	-	5	1	-	38d	2	-	136
4	-	6	2	-	40	4	-	142a
5	-	6a	1	-	45	1	-	143
4	-	7a	1	-	48	1	-	146a
6	-	8	9	-	48a	2	-	147b
2	-	8a	3	-	48b	2	-	155
4	-	9	2	-	48c	2	-	161
1	-	9d	1	-	51	1	-	163
1	-	9f	2	-	52	2	-	164
4	-	10	4	-	52a	1	-	165
5	-	11	4	-	53	2	-	176
1	-	11a	2	-	53a	2	-	179
12	-	12	2	-	54	5	-	188
2	-	12b	12	-	59	6	-	189
3	-	14	2	-	62	12	-	190
3	-	15	2	-	62b	3	-	191
2	-	15a	6	-	63	12	-	192
1	-	15b	2	-	70	1	-	193a
5	-	16	2	-	76	2	-	193c
2	-	16a	1	-	80c	2	-	193e
4	-	17	2	-	89	2	-	194
4	-	18a	4	-	90	3	-	194d
2	-	20	4	-	90a	6	-	197
2	-	20a	1	-	94	6	-	200
4	-	20b	1	-	95	1	-	201
5	-	22	1	-	95b	2	-	212
4	-	22a	1	-	96	4	-	214
3	-	23	1	-	96a	2	-	221
1	-	23a	2	-	99	2	-	224
1	-	24	2	-	100	2	-	225
1	-	24a	1	-	102	2	-	226
1	-	25	2	-	108	4	-	235
5	-	26	2	-	109			
1	-	27	2	-	111			

The base and roller bearing on which the Dragline body is mounted

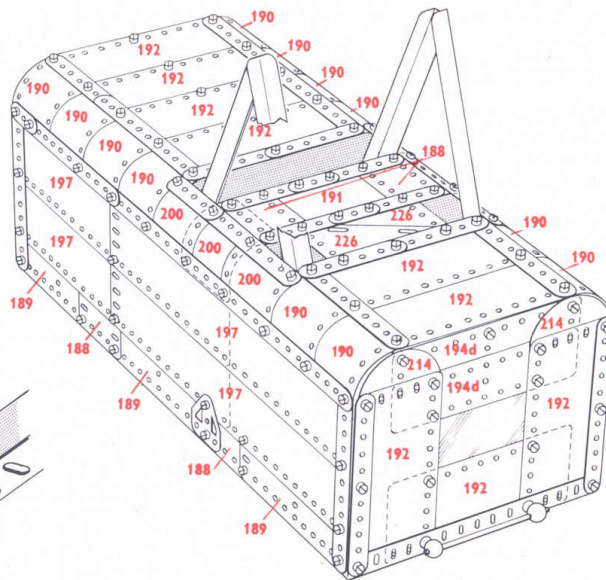
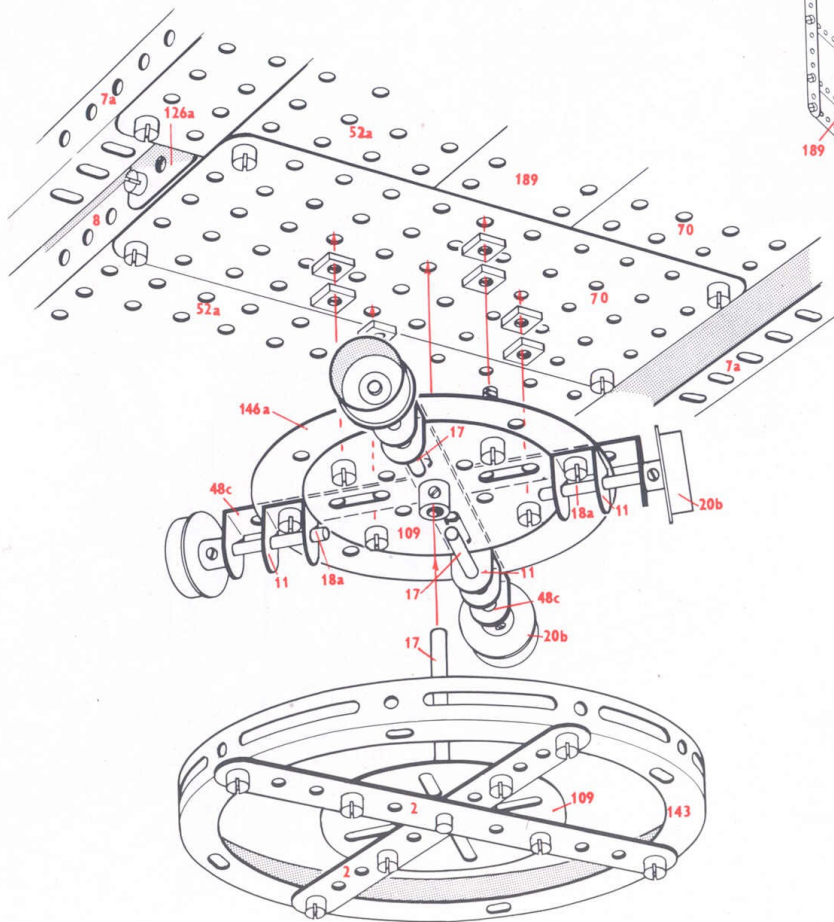

The body, seen from the front end

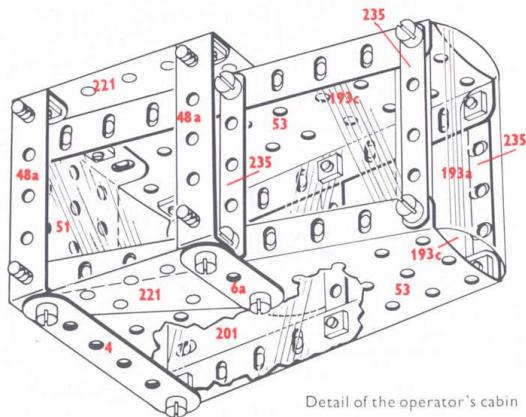

Detail of the operator's cabin

9.5 High-Speed Press

This Meccano model of a High-Speed Press is based on equipment in common use in industry where it is employed to stamp repetition components from strip steel or tinplate. The metal strip is fed into the press from a reel and passes over two rollers. These are power driven, and by turning intermittently, carry the strip through the press. In the model, the punching device consists of three rods which rise and fall vertically and mate with holes in the work table. The punching motion is actuated by means of an eccentric drive from the main shaft. This shaft, on one end of which is a heavy flywheel, is driven by a Meccano E15R Electric Motor. At the other end of the main shaft a crank mechanism converts the rotary motion of the shaft into the reciprocal motion required to actuate the intermittent motion of the feed rollers.

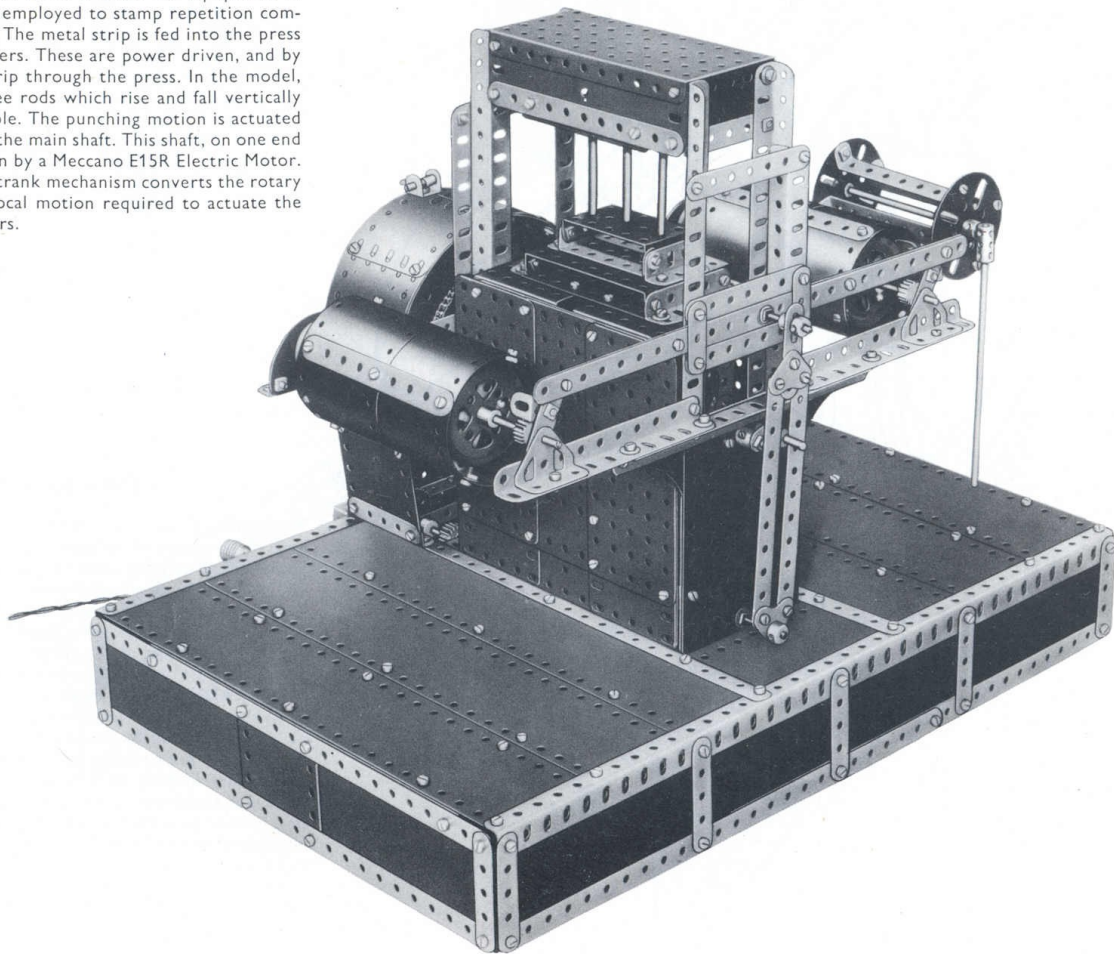

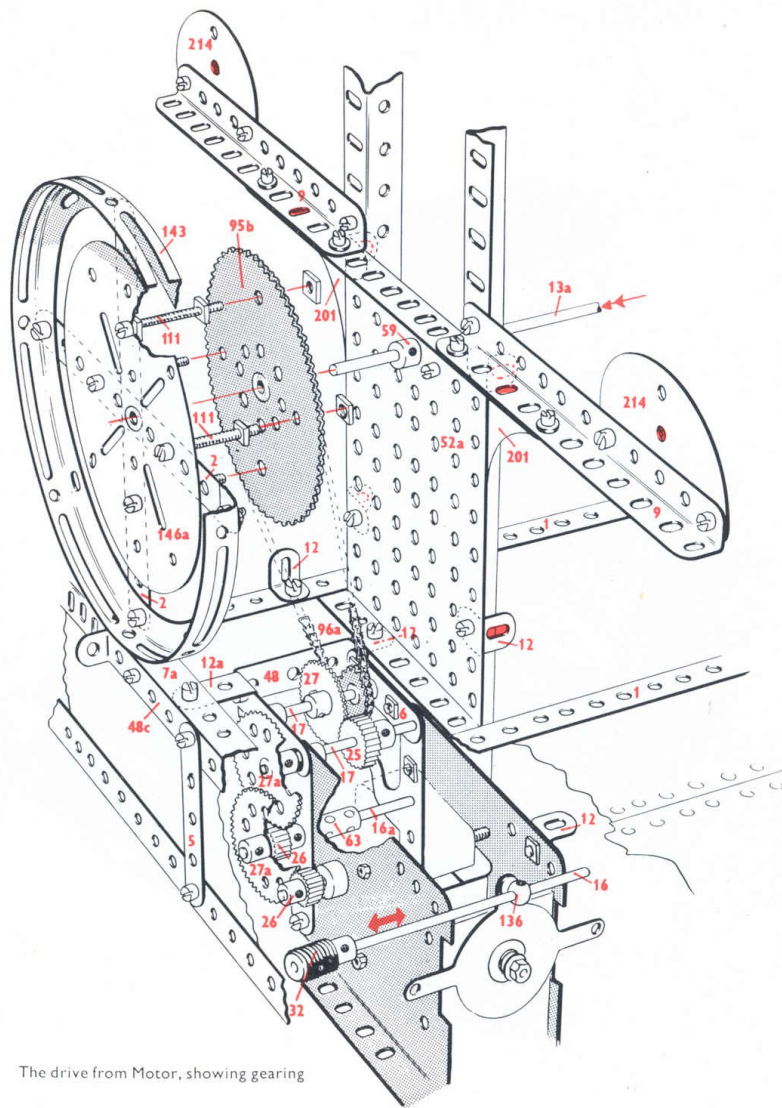

The drive from Motor, showing gearing

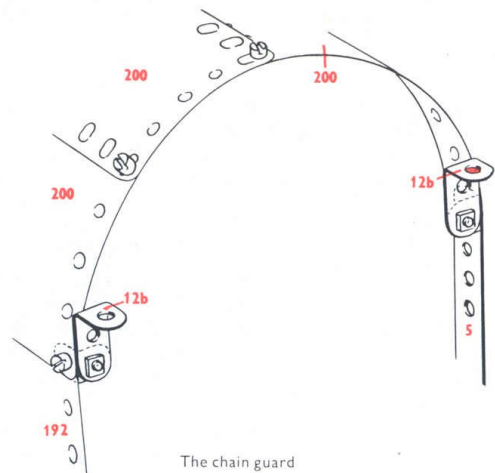

The chain guard

How to use this leaflet

The constructional details of the model shown in this Leaflet are explained entirely by means of half-tone illustrations and line drawings. Once the 'knack' of reading the drawings has been acquired assembly of the model will be found quite straightforward and simple to carry out.

Before starting to build the model it is advisable to study all the illustrations carefully so as to get a good idea of its various sections. Points at which various units of the model are bolted together to form the complete structure are indicated in the drawings by RED DOTS or RED BOLTHEADS whenever possible.

The particular parts used in the assembly of the model can in most cases be identified simply by looking at the illustrations, but where the identity of a part may not be quite clear, its Part Number is printed on the model illustrations in RED. RED DOTTED pointer lines are used to indicate parts that are hidden behind other parts of the structure.

As a further help a list of the parts required to build the model is given in this Leaflet. In this list the catalogue numbers of the parts are printed in RED and the quantity of each part in BLACK.

In models fitted with a driving Motor the particular type of Motor is indicated by one of the following Code Marks: M1 = Magic Clockwork Motor; M2 = No. 1 Clockwork Motor; M3 = Meccano Electric Motor.

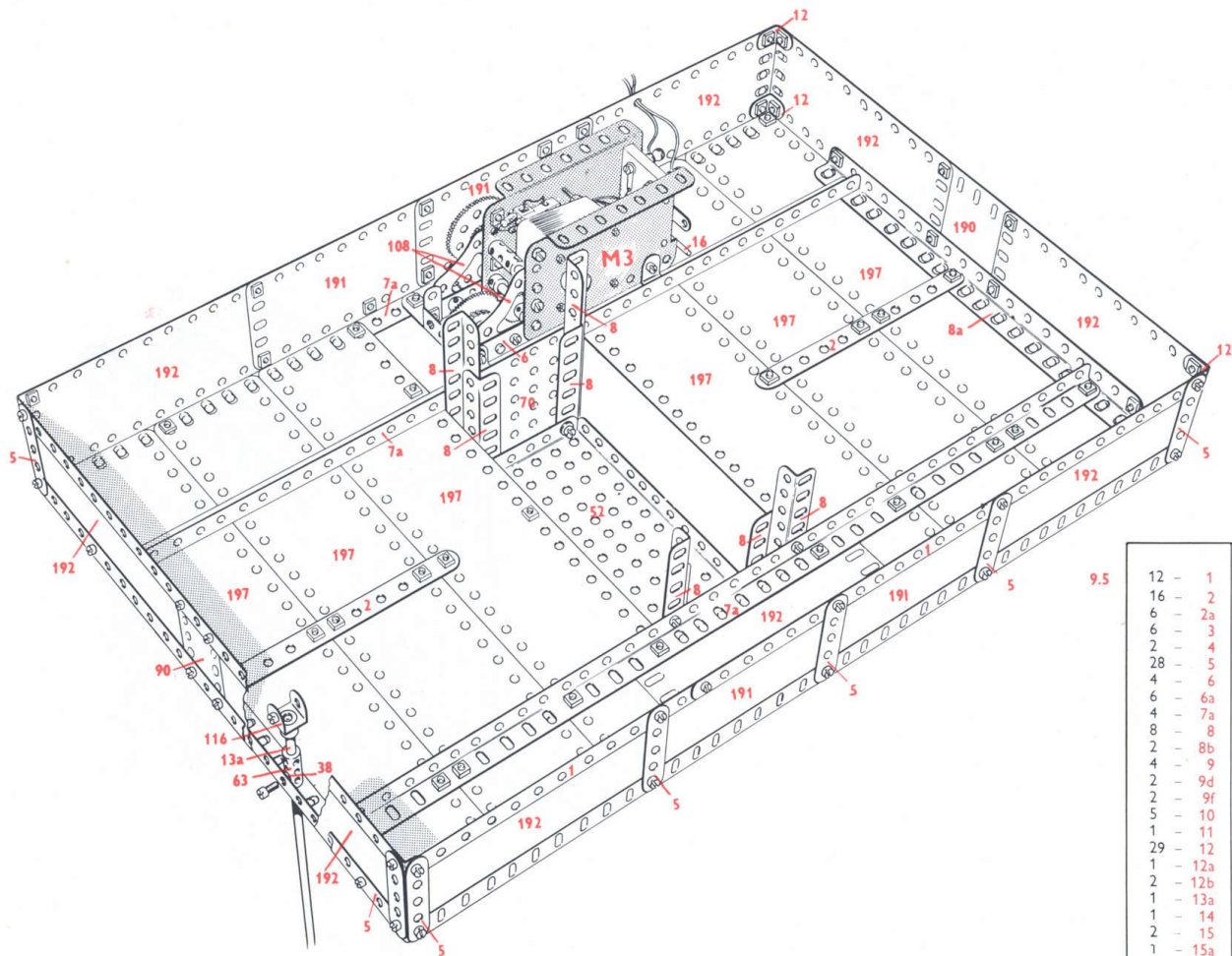

Underneath view of the base of the Press showing location of the driving Motor

12	-	1	2	-	22	4	-	111
16	-	2	1	-	25	8	-	111c
6	-	2a	4	-	26	2	-	115a
6	-	3	1	-	27	1	-	116
2	-	4	2	-	27a	2	-	126
28	-	5	1	-	32	2	-	133a
4	-	6	316	-	37a	1	-	136
6	-	6a	294	-	37b	1	-	143
4	-	7a	24	-	38	1	-	146a
8	-	8	2	-	45	1	-	154a
2	-	8b	2	-	46	1	-	154b
4	-	9	10	-	48a	2	-	155
2	-	9d	5	-	48b	1	-	173a
2	-	9f	2	-	48c	1	-	179
5	-	10	1	-	51	6	-	188
1	-	11	2	-	52	6	-	189
29	-	12	4	-	53	4	-	190
1	-	12a	2	-	53a	4	-	191
2	-	12b	1	-	55a	11	-	192
1	-	13a	12	-	59	4	-	194c
1	-	14	2	-	62	4	-	194e
2	-	15	2	-	62b	6	-	197
1	-	15a	4	-	63	6	-	200
2	-	15b	2	-	70	2	-	201
3	-	16	4	-	90	1	-	212a
3	-	16a	4	-	90a	2	-	214
3	-	17	1	-	94	8	-	215
1	-	18a	1	-	95b	2	-	221
1	-	18b	1	-	96a	2	-	222
4	-	20a	2	-	108			
2	-	21	2	-	109			

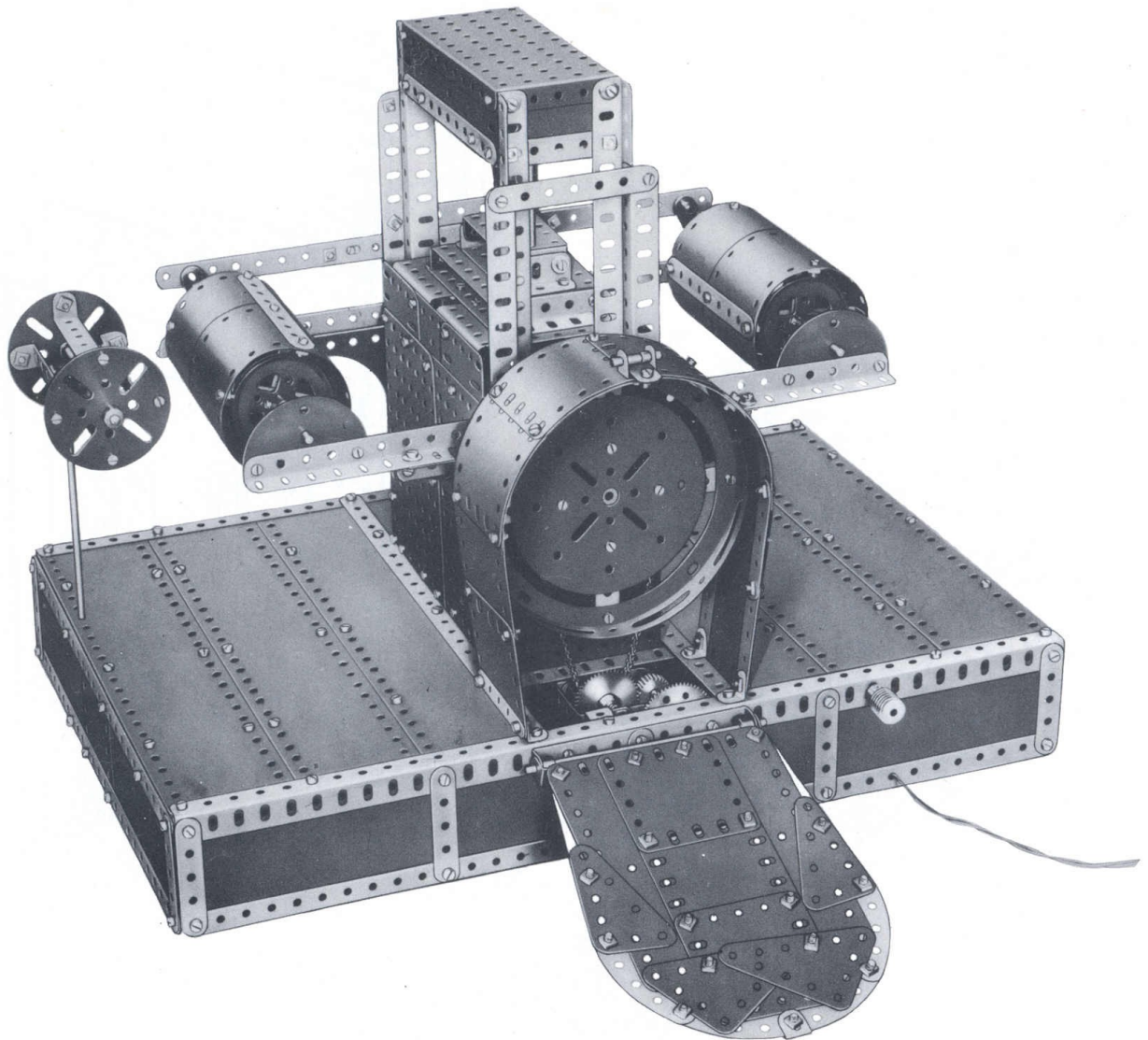

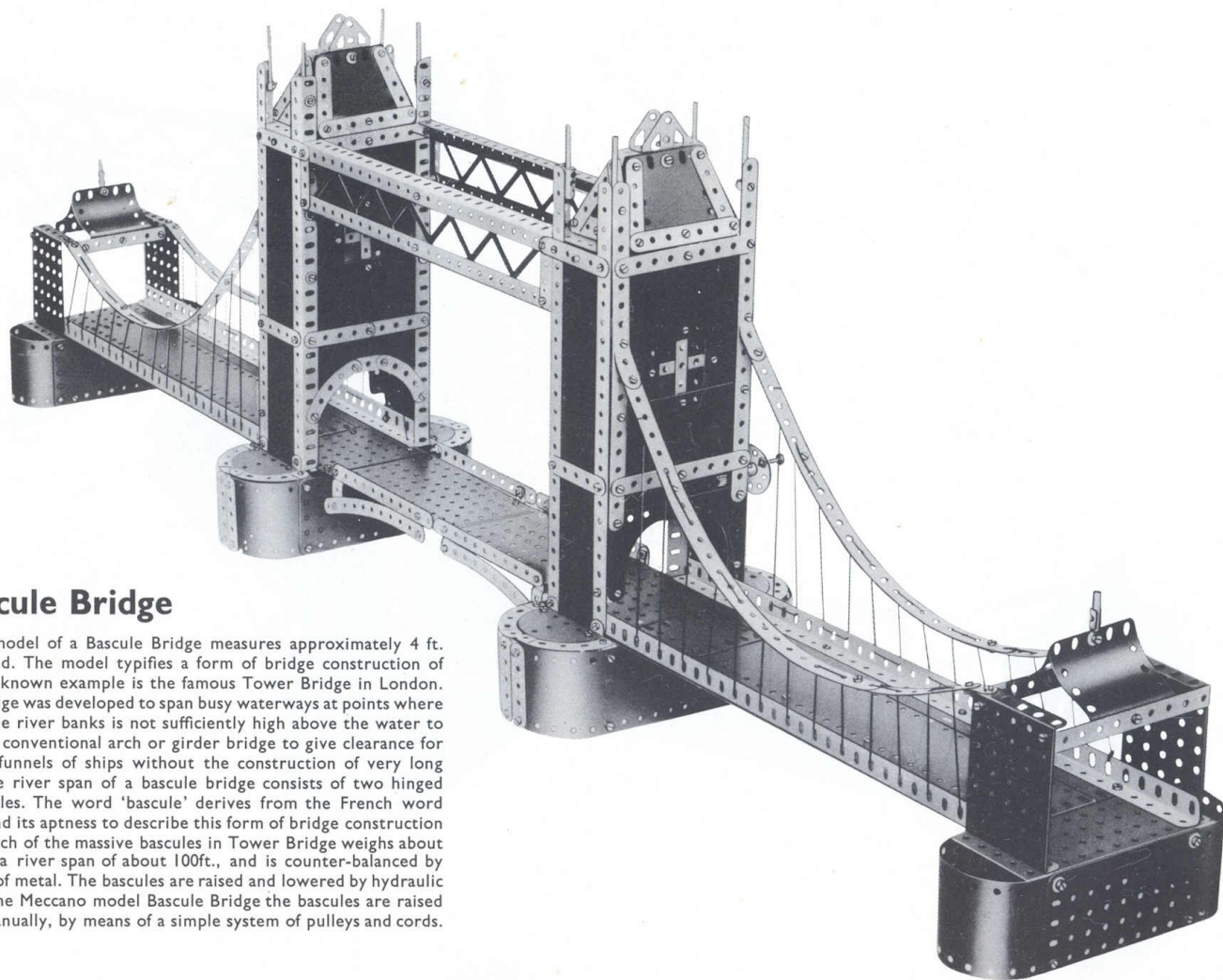

9.6 Bascule Bridge

This Meccano model of a Bascule Bridge measures approximately 4 ft. from end to end. The model typifies a form of bridge construction of which the best known example is the famous Tower Bridge in London. This type of bridge was developed to span busy waterways at points where the height of the river banks is not sufficiently high above the water to allow the more conventional arch or girder bridge to give clearance for the masts and funnels of ships without the construction of very long approaches. The river span of a bascule bridge consists of two hinged leaves or bascules. The word 'bascule' derives from the French word for 'see-saw', and its aptness to describe this form of bridge construction will be plain. Each of the massive bascules in Tower Bridge weighs about 1,200 tons, has a river span of about 100ft., and is counter-balanced by about 350 tons of metal. The bascules are raised and lowered by hydraulic machinery. In the Meccano model Bascule Bridge the bascules are raised and lowered manually, by means of a simple system of pulleys and cords.

Special Model Leaflet

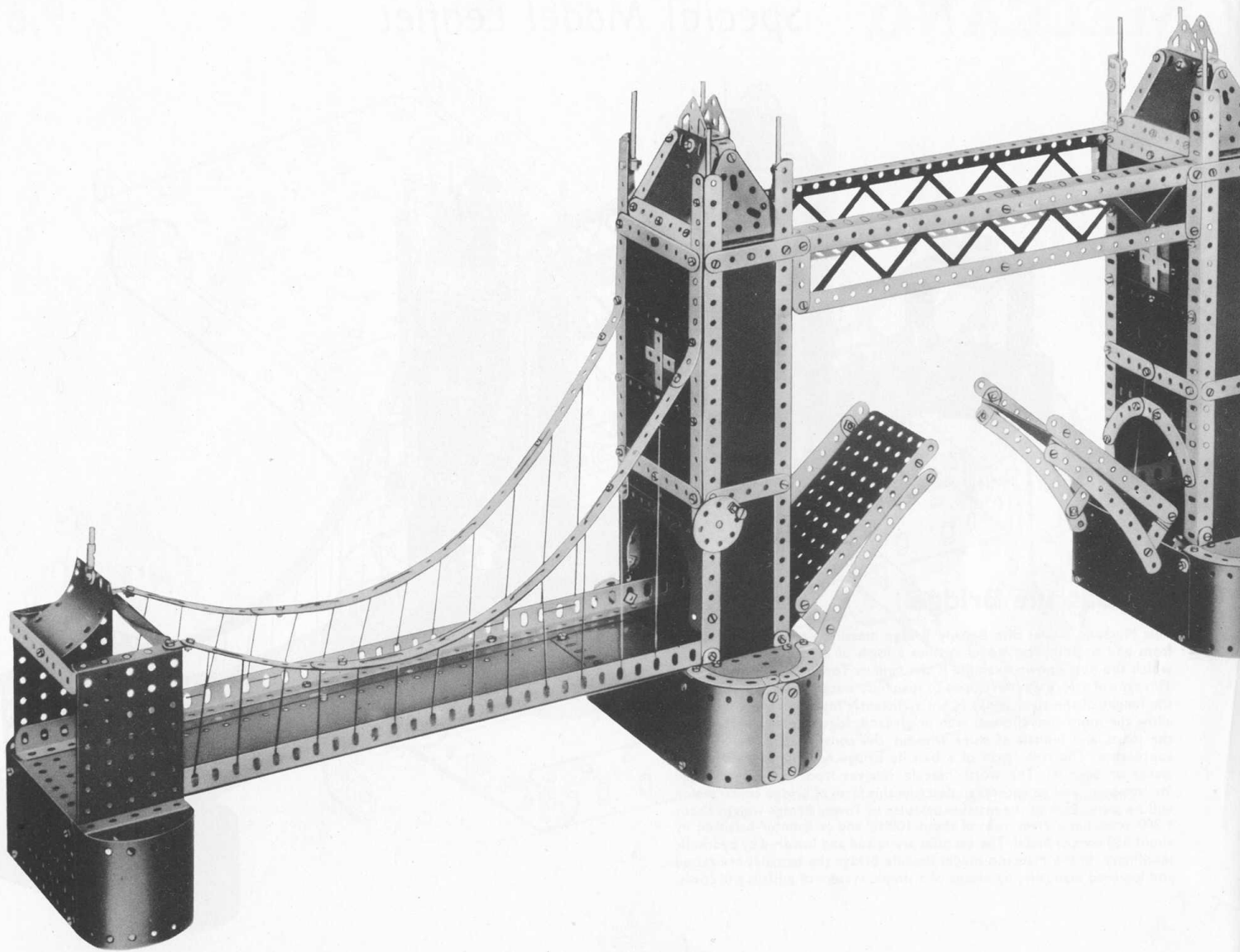

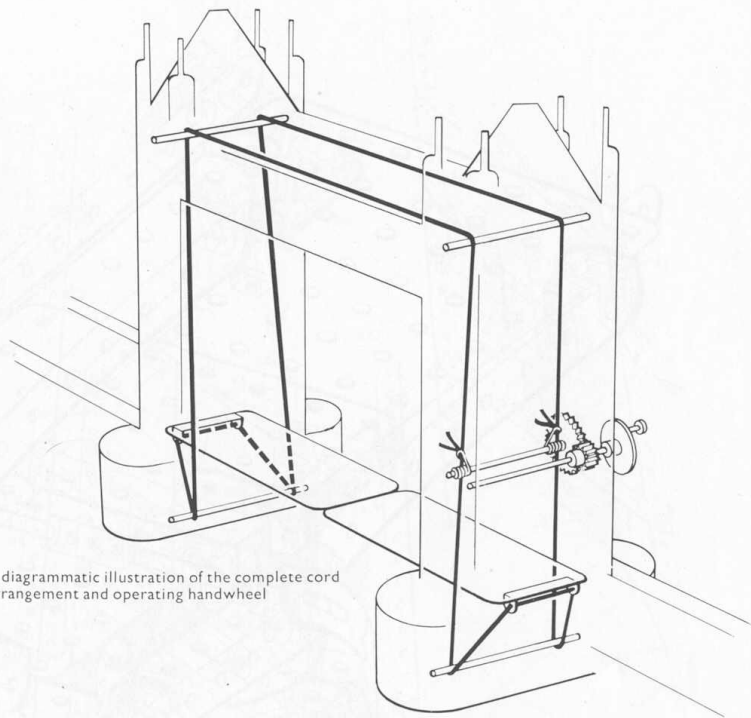
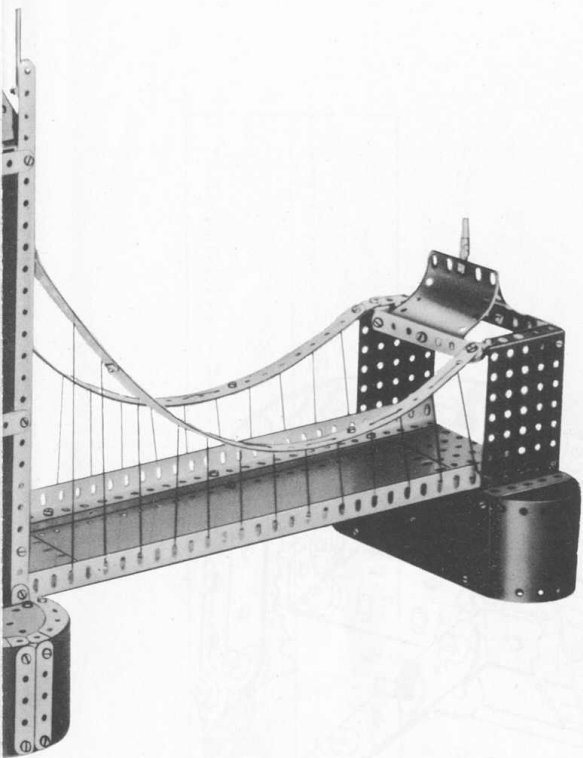

A diagrammatic illustration of the complete cord arrangement and operating handwheel

How to use this leaflet

The constructional details of the model shown in this Leaflet are explained entirely by means of half-tone illustrations and line drawings. Once the 'knack' of reading the drawings has been acquired assembly of the model will be found quite straightforward and simple to carry out.

Before starting to build the model it is advisable to study all the illustrations carefully so as to get a good idea of its various sections. Points at which various units of the model are bolted together to form the complete structure are indicated in the drawings by RED DOTS or RED BOLTHEADS whenever possible.

The particular parts used in the assembly of the model can in most cases

be identified simply by looking at the illustrations, but where the identity of a part may not be quite clear, its Part Number is printed on the model illustrations in RED. RED DOTTED pointer lines are used to indicate parts that are hidden behind other parts of the structure.

As a further help a list of the parts required to build the model is given in this Leaflet. In this list the catalogue numbers of the parts are printed in RED and the quantity of each part in BLACK.

In models fitted with a driving Motor the particular type of Motor is indicated by one of the following Code Marks: M1 = Magic Clockwork Motor; M2 = No. 1 Clockwork Motor; M3 = Meccano Electric Motor.

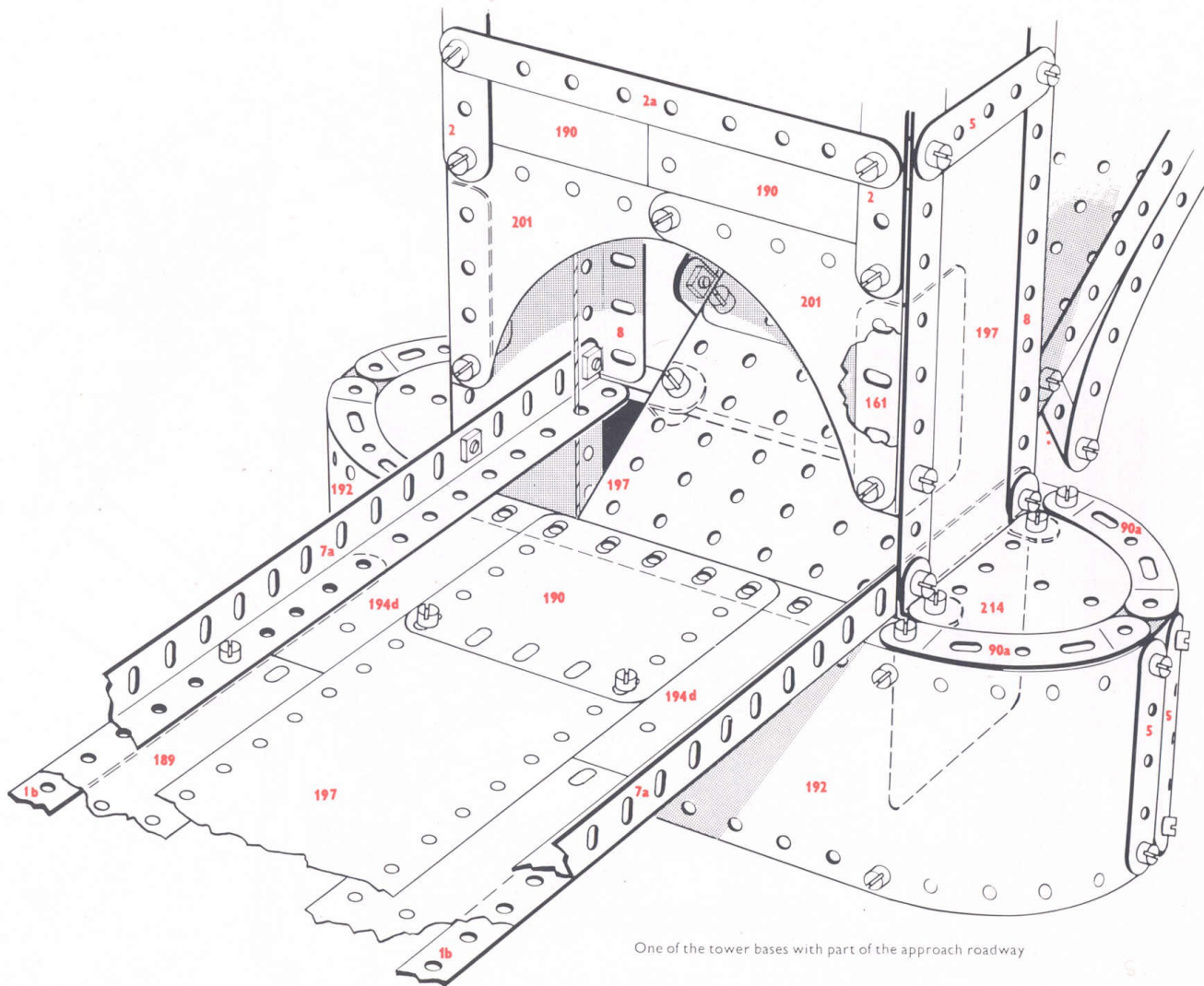

One of the tower bases with part of the approach roadway

9.6

14	-	1	2	-	52
2	-	1b	4	-	52d
14	-	2	4	-	53
6	-	2a	2	-	53a
6	-	3	11	-	59
8	-	4	6	-	63
32	-	5	2	-	70
4	-	6	2	-	76
2	-	6a	4	-	89
4	-	7a	4	-	90
8	-	8	8	-	90a
4	-	9	2	-	99
2	-	9f	6	-	111c
12	-	10	4	-	125
2	-	11	4	-	126
30	-	12	2	-	126a
4	-	12a	1	-	147b
2	-	12b	1	-	154a
8	-	12c	1	-	154b
2	-	14	2	-	161
2	-	15	2	-	165
1	-	15a	2	-	176
1	-	15b	8	-	188
2	-	16	6	-	189
2	-	16a	9	-	190
4	-	17	4	-	191
4	-	18a	8	-	192
2	-	18b	2	-	193
1	-	24	2	-	193a
1	-	26	1	-	194
1	-	27a	2	-	194a
9	-	35	4	-	194c
331	-	37a	4	-	194d
321	-	37b	4	-	194e
25	-	38	6	-	197
2	-	40	4	-	200
4	-	46	4	-	201
2	-	48	2	-	212
8	-	48a	4	-	214
6	-	48b	8	-	215
2	-	48c	4	-	221
2	-	48d	6	-	235
2	-	51	2	-	235a

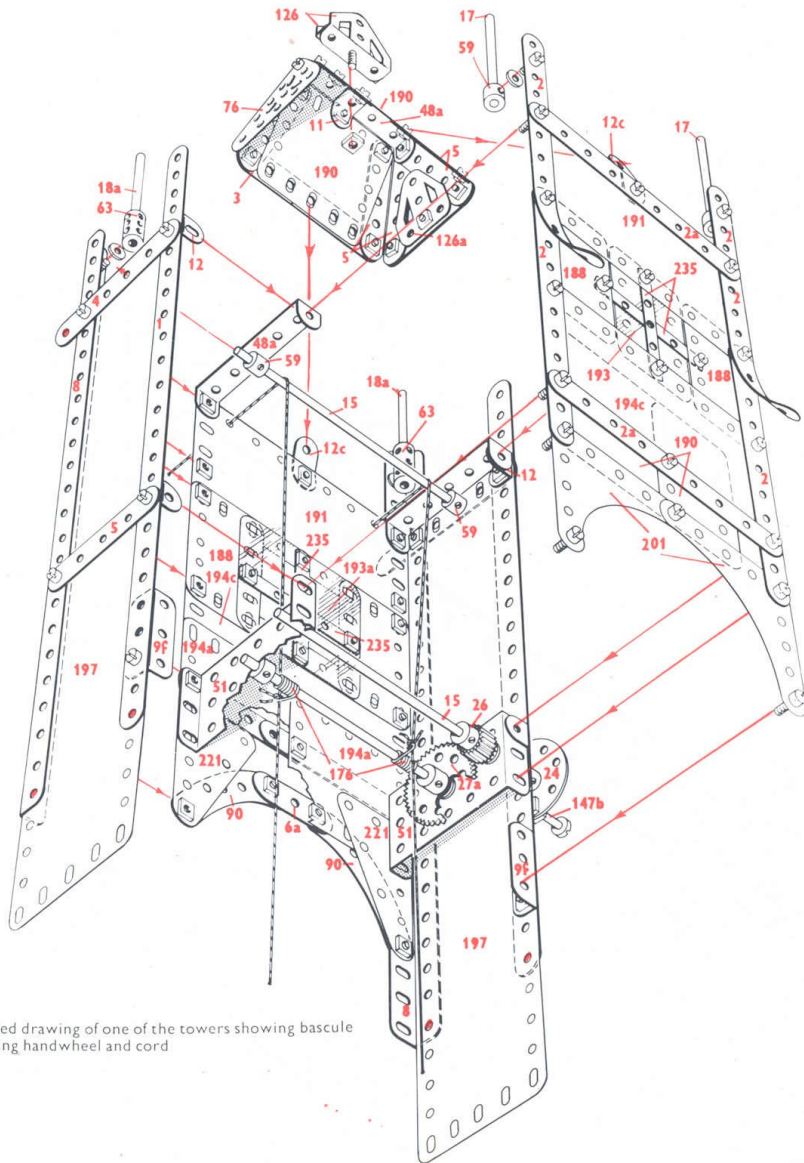

Exploded drawing of one of the towers showing bascule operating handwheel and cord

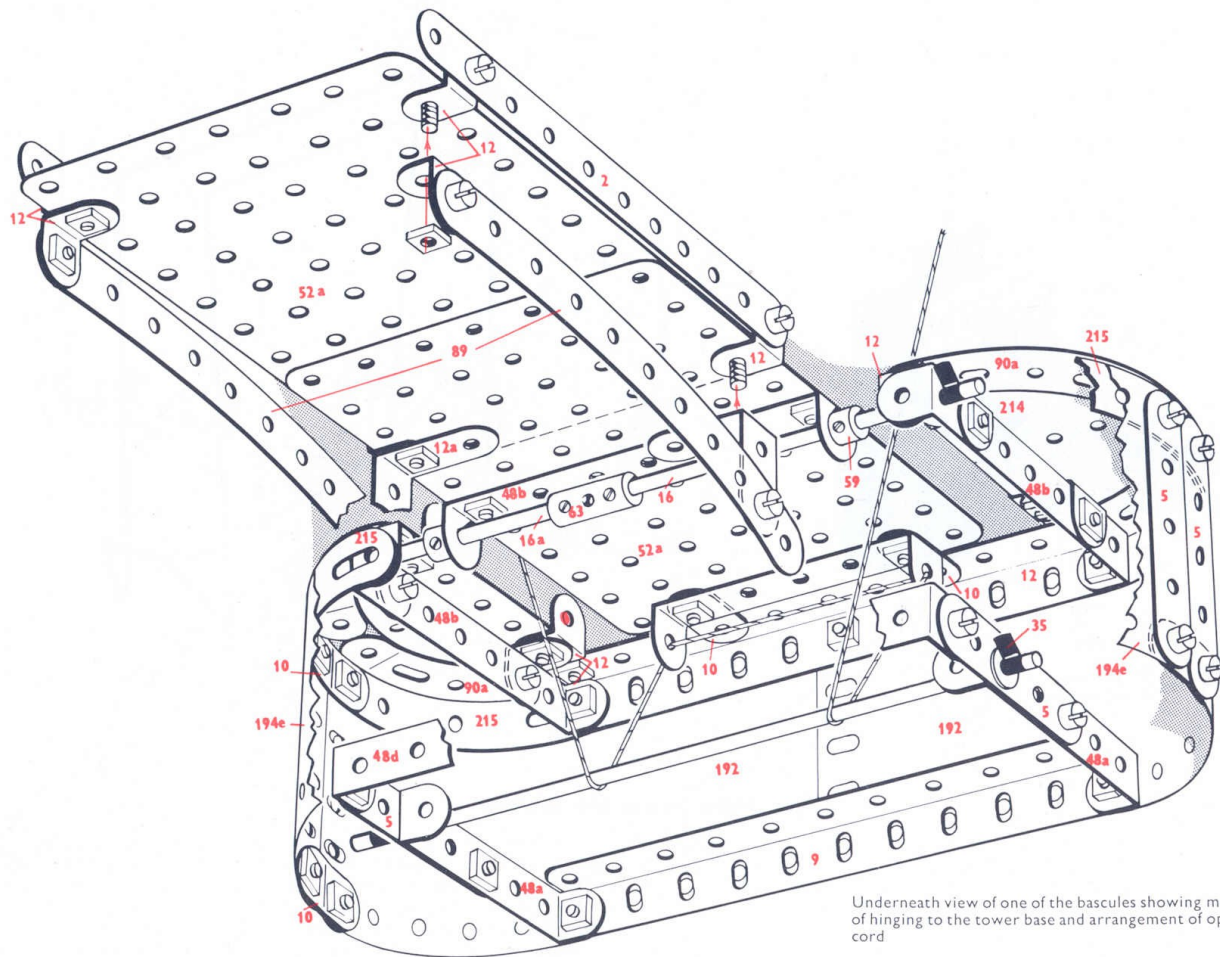

Underneath view of one of the bascules showing method of hinging to the tower base and arrangement of operating cord

9.7 Robot Man

This Meccano model of a Robot or Mechanical Man stands over 3 ft. high. It is powered by a Meccano E15R Electric Motor, which by an ingenious series of linkages, causes the Robot to walk slowly along, swinging his arms and turning his head from side to side.

From a mechanical point of view the model is of particular interest in that it provides an excellent illustration of how a single power source can be harnessed by means of gear and chain drives and the use of cranks and levers, to operate no less than five separate but synchronized reciprocal motions.

How to use this leaflet

The constructional details of the model shown in this Leaflet are explained entirely by means of half-tone illustrations and line drawings. Once the knack of 'reading' the drawings has been acquired assembly of the model will be found quite straightforward and simple to carry out.

Before starting to build the model it is advisable to study all the illustrations carefully so as to get a good idea of its various sections. Points at which various units of the model are bolted together to form the complete structure are indicated in the drawings by RED DOTS or RED BOLTHEADS whenever possible.

The particular parts used in the assembly of the model can in most cases be identified simply by looking at the illustrations, but where the identity of a part may not be quite clear, its Part Number is printed on the model illustrations in RED. RED DOTTED pointer lines are used to indicate parts that are hidden behind other parts of the structure.

As a further help a list of the parts required to build the model is given in this Leaflet. In this list the catalogue numbers of the parts are printed in RED and the quantity of each part in BLACK.

In models fitted with a driving Motor the particular type of Motor is indicated by one of the following Code Marks: M1 = Magic Clockwork Motor; M2 = No. 1 Clockwork Motor; M3 = Meccano Electric Motor.

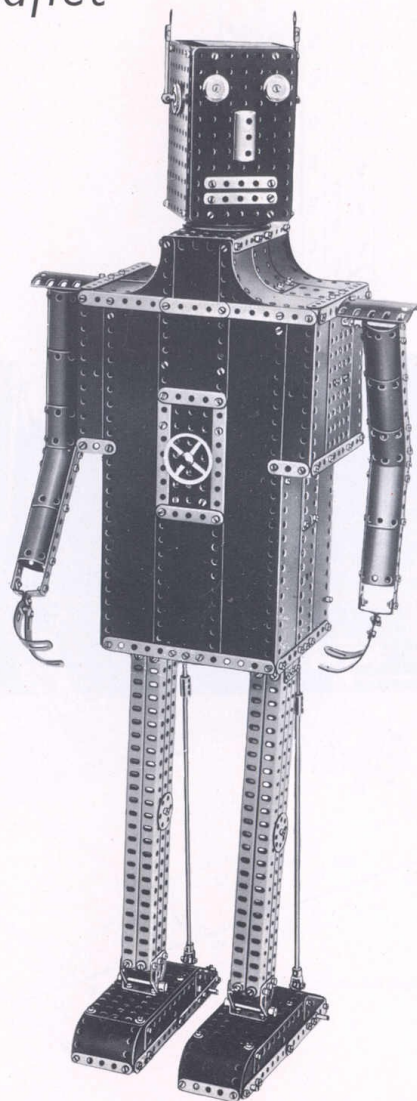

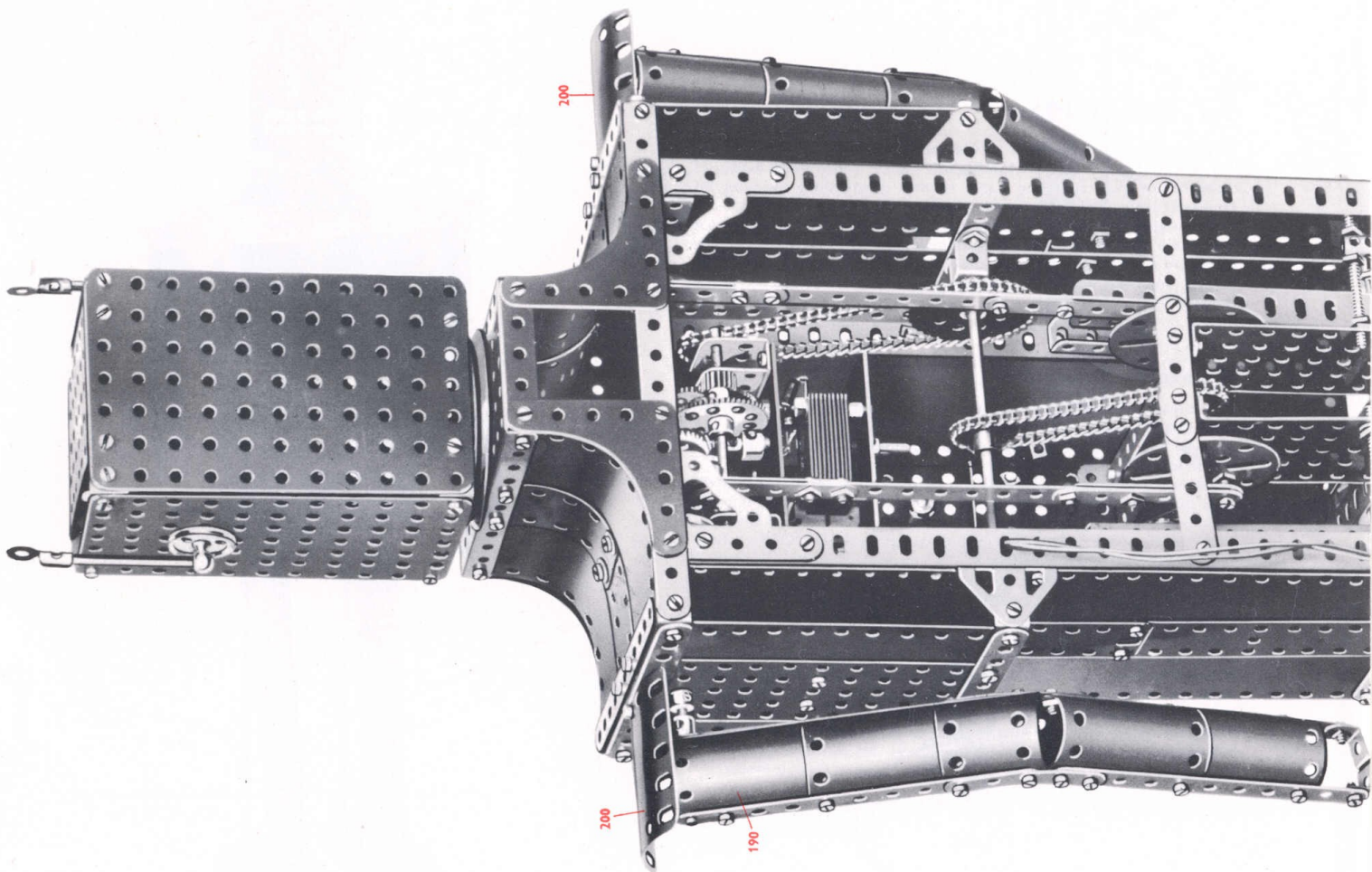

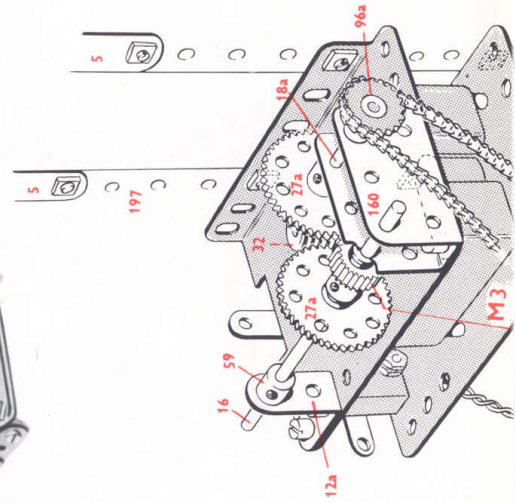
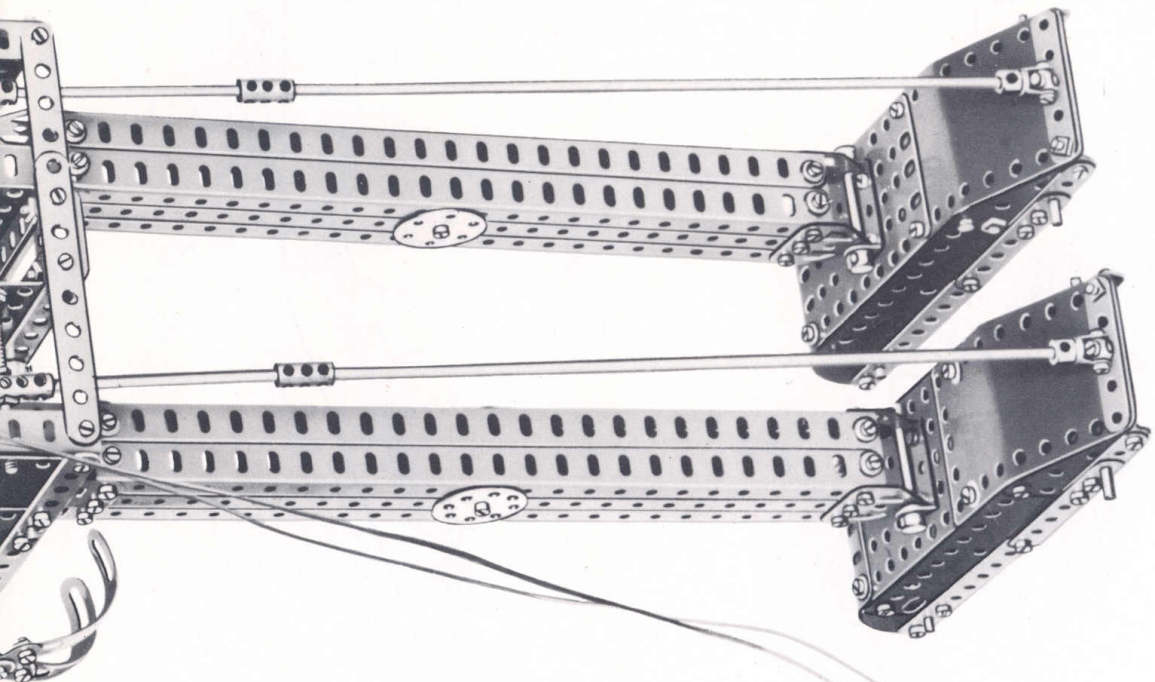

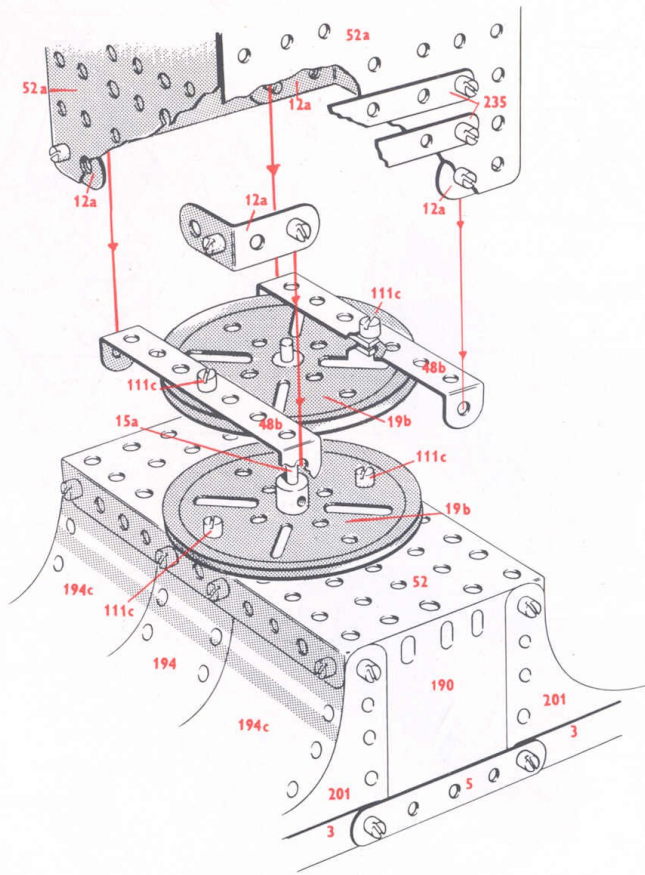

Shoulders of the Robot showing bearing on which the head swivels

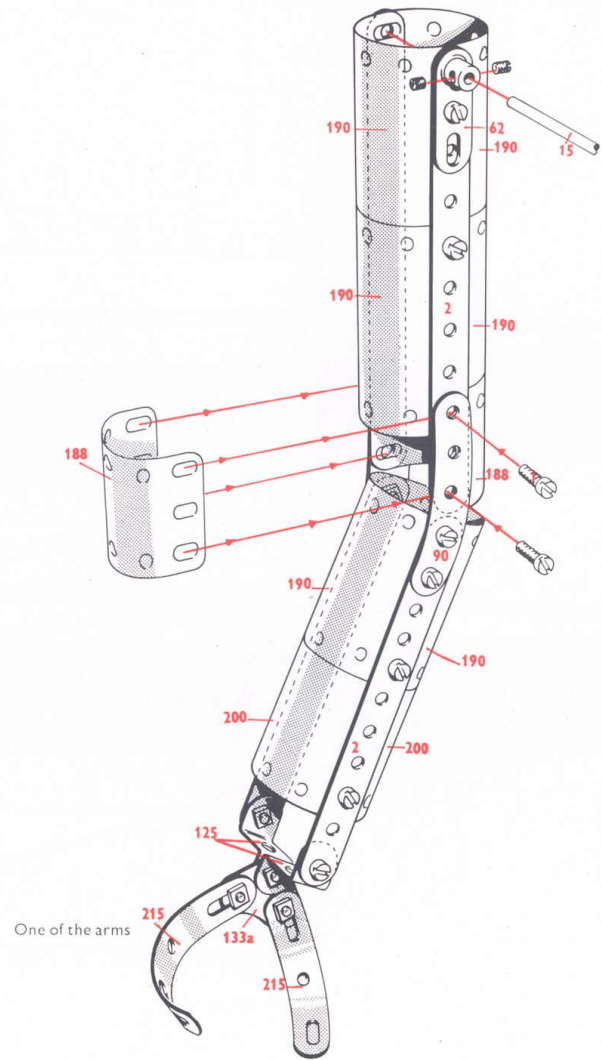

One of the arms

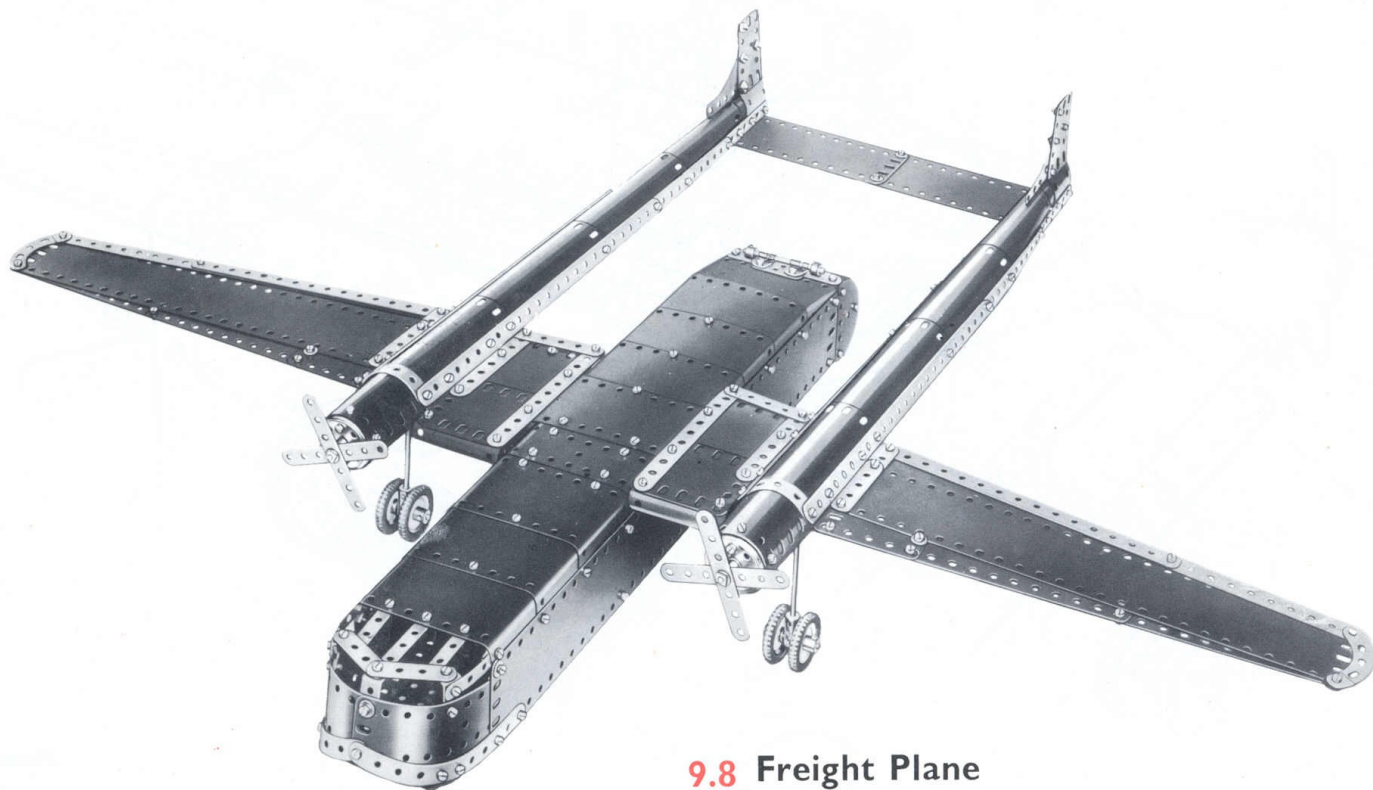

9.8 Freight Plane

This Meccano model is based on a type of aircraft of somewhat unusual design. Powered by two engines housed in long nacelles, which extend backwards to support the tail structure, the aircraft is essentially a box-like structure designed to accommodate bulky and weighty freight. This type of aircraft was first developed for military use and the hinged door and extending ramp at the rear of the fuselage allow such items as field guns and military vehicles to be easily hoisted aboard.

In recent years airlines throughout the world have become aware of the commercial application of aircraft of this type and to meet the growing demand for airfreight services, a number of aircraft manufacturers in Britain have developed aircraft for the specific purpose of carrying freight.

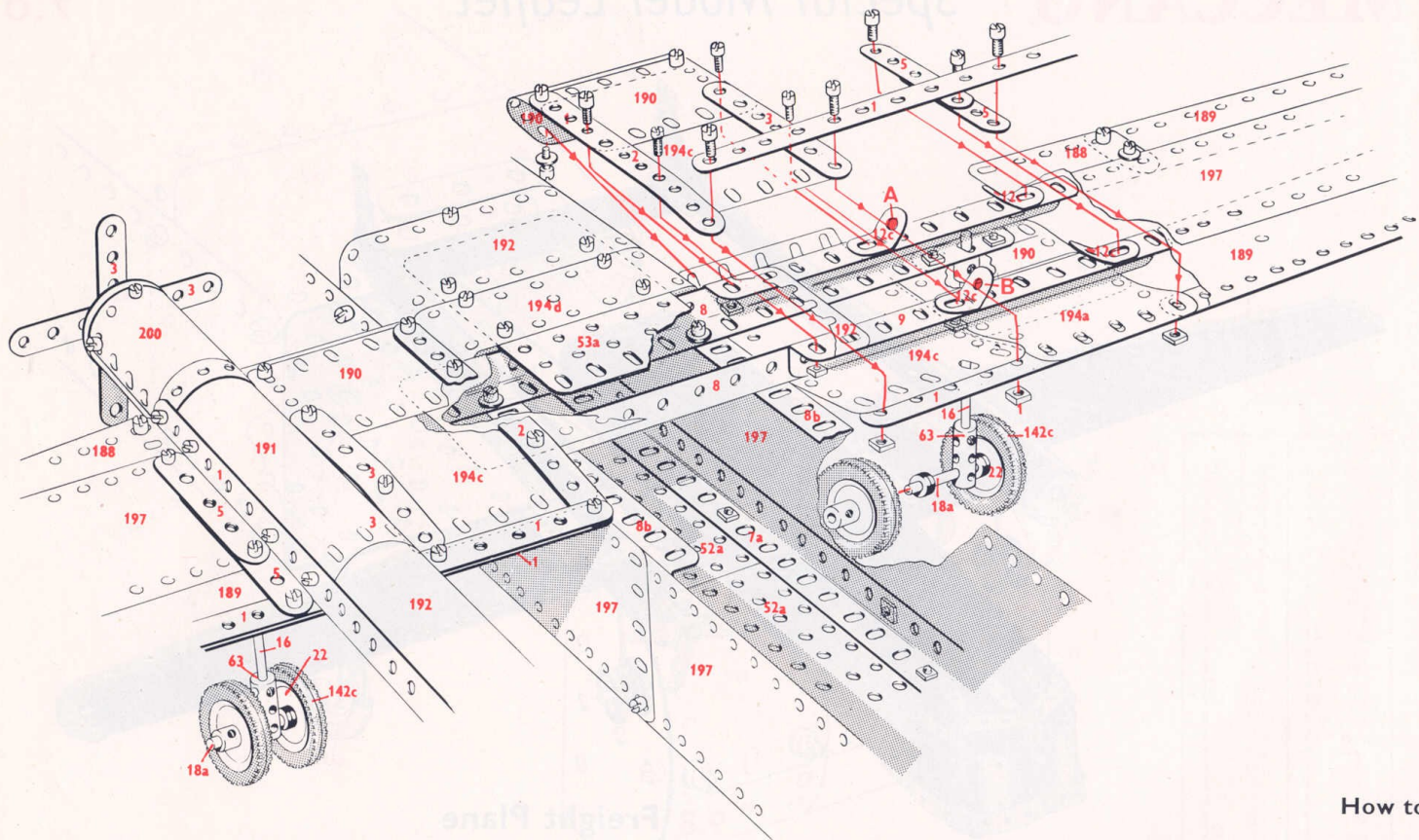

Exploded section of the fore part of fuselage, with part of wing

How to use

The constructional details of the model shown in this Leaflet are explained entirely by means of half-tone illustrations and line drawings. Once the 'knack' of reading the drawings has been acquired assembly of the model will be found quite straightforward and simple to carry out. Before starting to build the model it is advisable to study all the illustrations carefully so as to get a good idea of its various sections. Points at which various units of the model are bolted together to form the complete structure are indicated in the drawings by RED DOTS or RED BOLTHEADS whenever possible. The particular parts used in the assembly of the model can in most cases

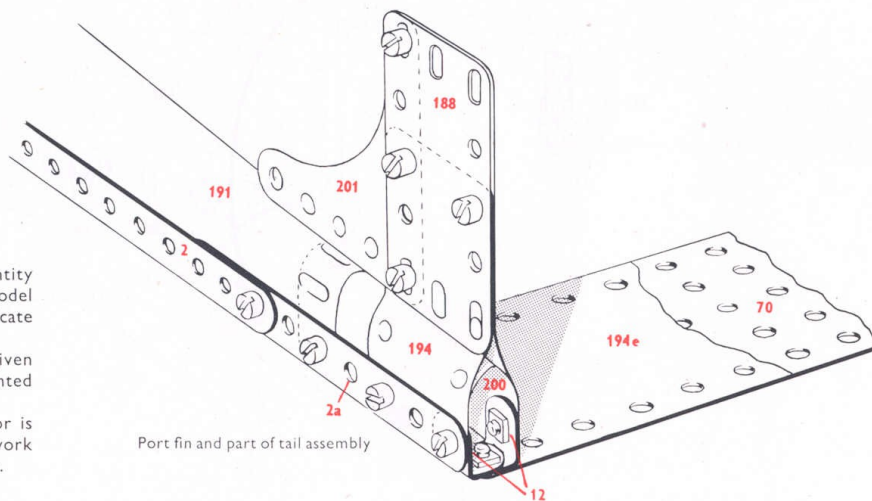
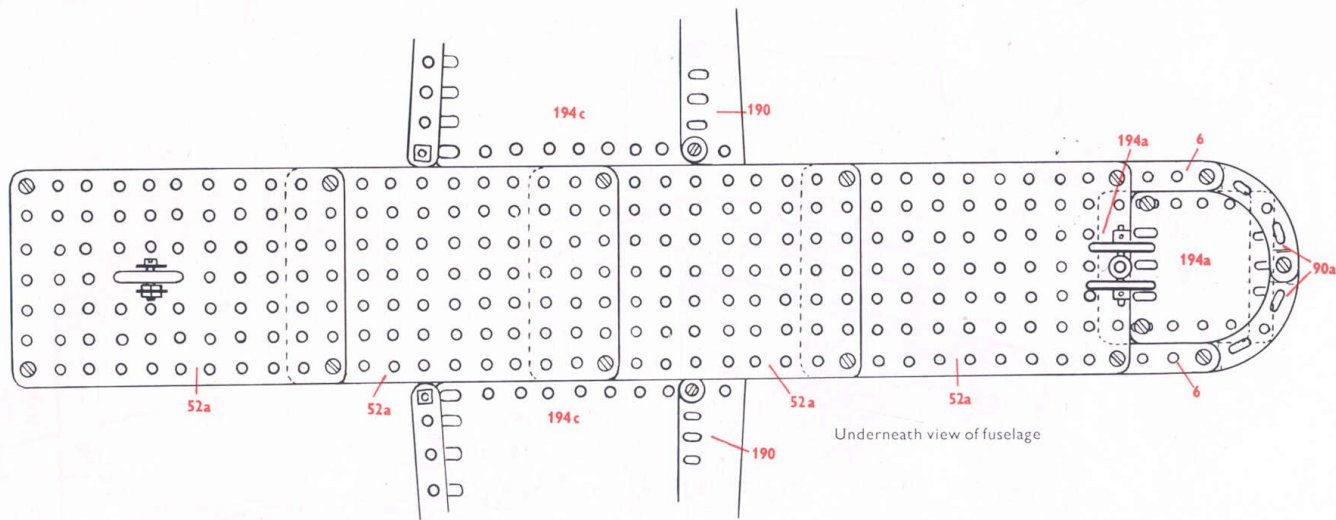

this leaflet

be identified simply by looking at the illustrations, but where the identity of a part may not be quite clear, its Part Number is printed on the model illustrations in RED. RED DOTTED pointer lines are used to indicate parts that are hidden behind other parts of the structure.

As a further help a list of the parts required to build the model is given in this Leaflet. In this list the catalogue numbers of the parts are printed in RED and the quantity of each part in BLACK.

In models fitted with a driving Motor the particular type of Motor is indicated by one of the following Code Marks: M1 = *Magic* Clockwork Motor; M2 = No. 1 Clockwork Motor; M3 = Meccano Electric Motor.

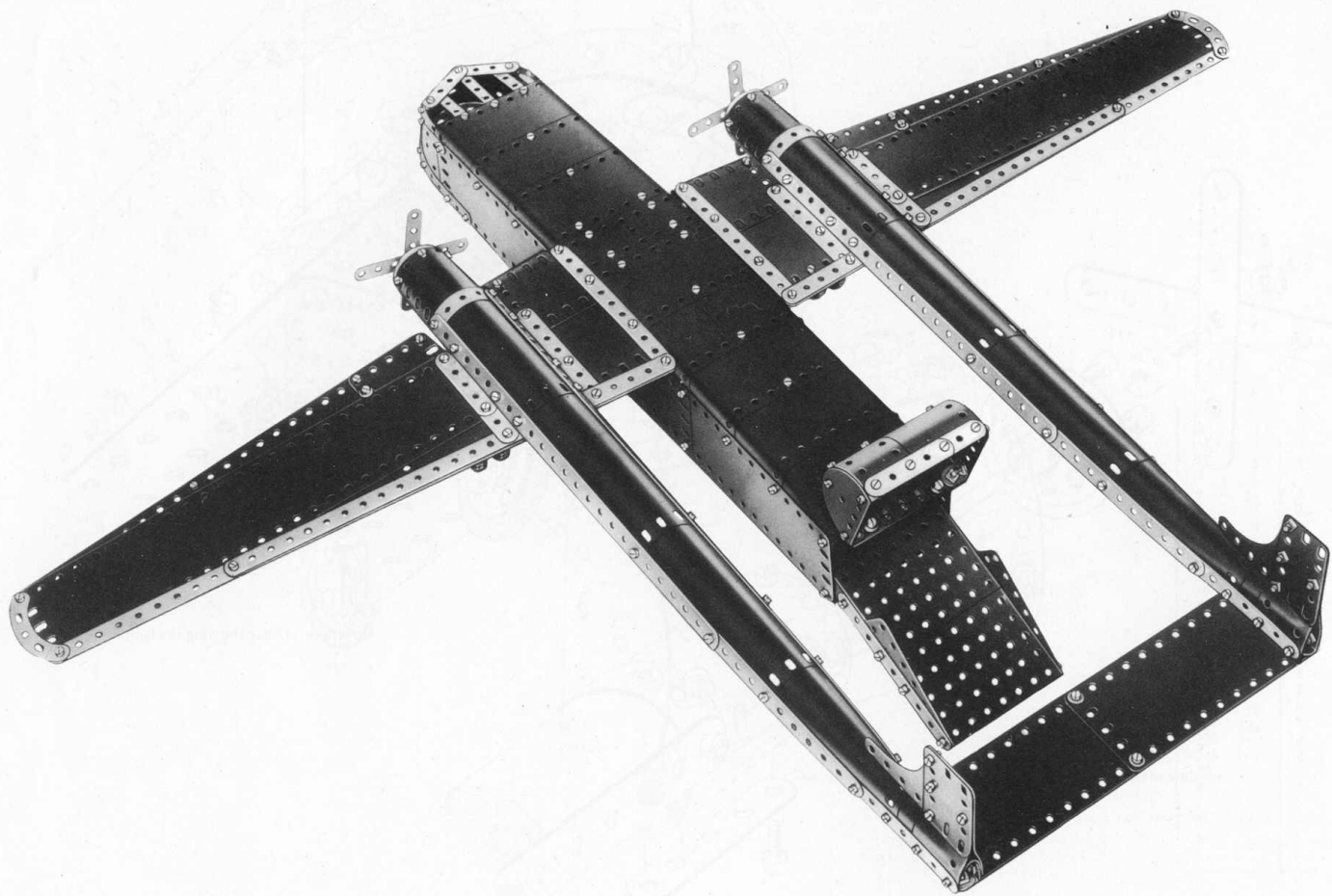

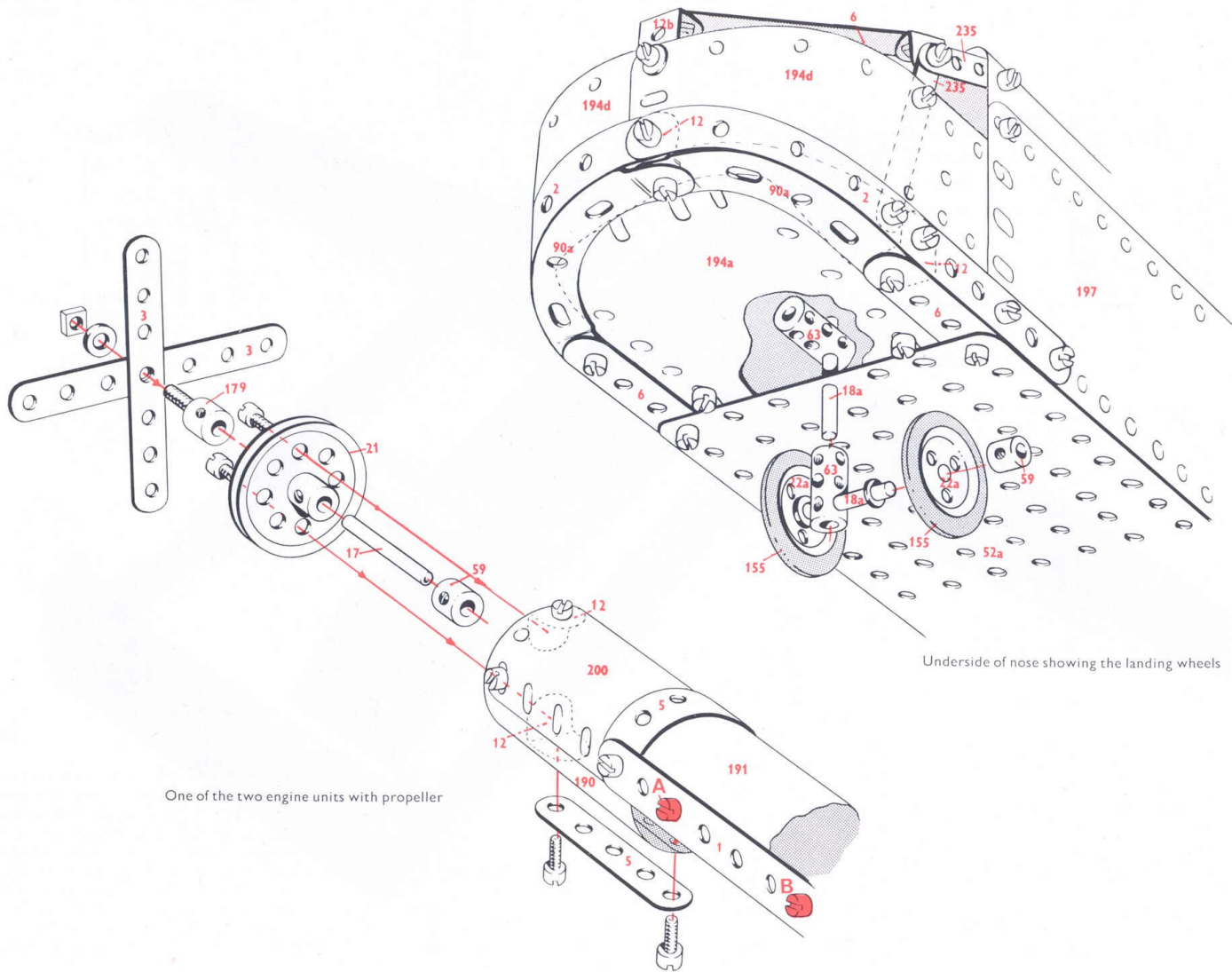

Underside of nose showing the landing wheels

One of the two engine units with propeller

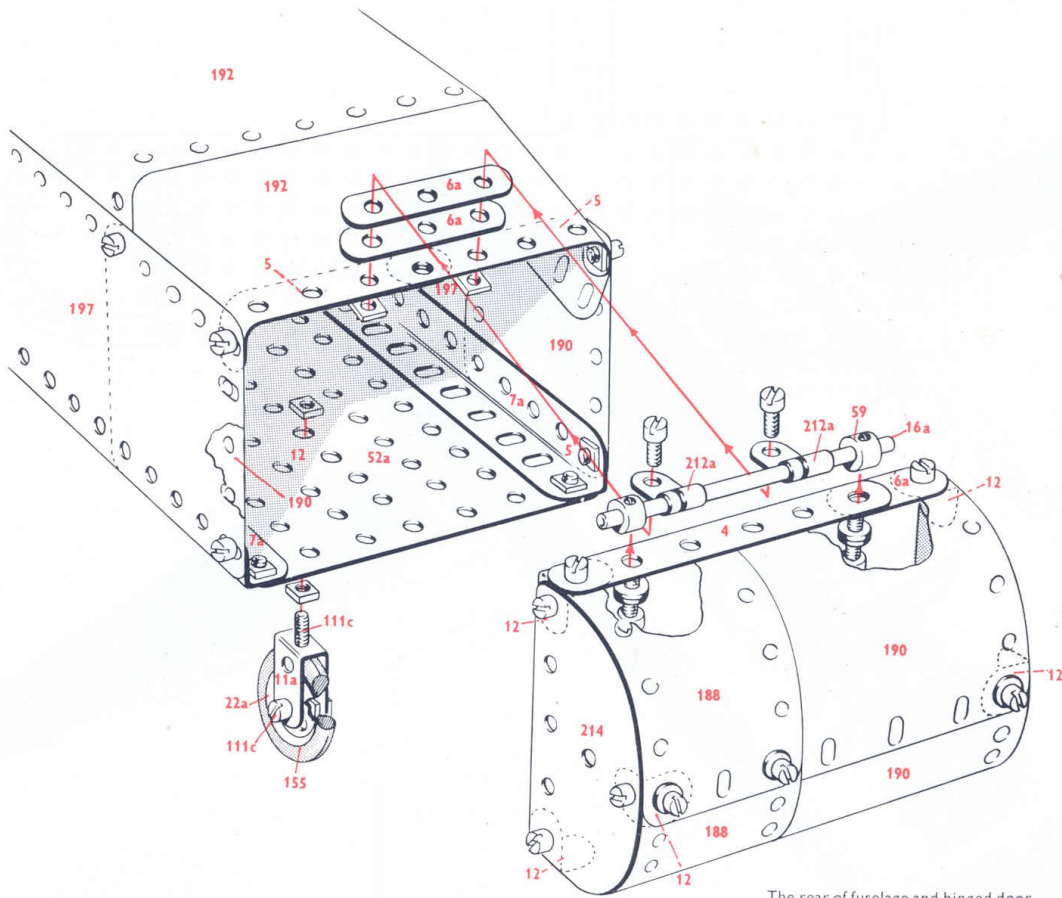

The rear of fuselage and hinged door

9.8

12	-	1	2	-	62b
7	-	2	3	-	63
5	-	2a	2	-	89
6	-	3	4	-	90a
1	-	4	1	-	102
12	-	5	1	-	111a
4	-	6	1	-	111c
4	-	6a	4	-	142c
2	-	7a	3	-	155
2	-	8	2	-	179
2	-	8b	10	-	188
4	-	9	6	-	189
2	-	11	12	-	190
19	-	12	4	-	191
1	-	12b	12	-	192
8	-	12c	4	-	194
2	-	16	2	-	194a
3	-	16a	4	-	194c
4	-	18a	3	-	194d
2	-	21	2	-	194e
4	-	22	6	-	197
3	-	22a	1	-	199
220	-	37a	3	-	200
215	-	37b	2	-	201
28	-	38	2	-	212a
4	-	52a	2	-	214
2	-	53	2	-	224
1	-	53a	4	-	235
6	-	59	1	-	235a

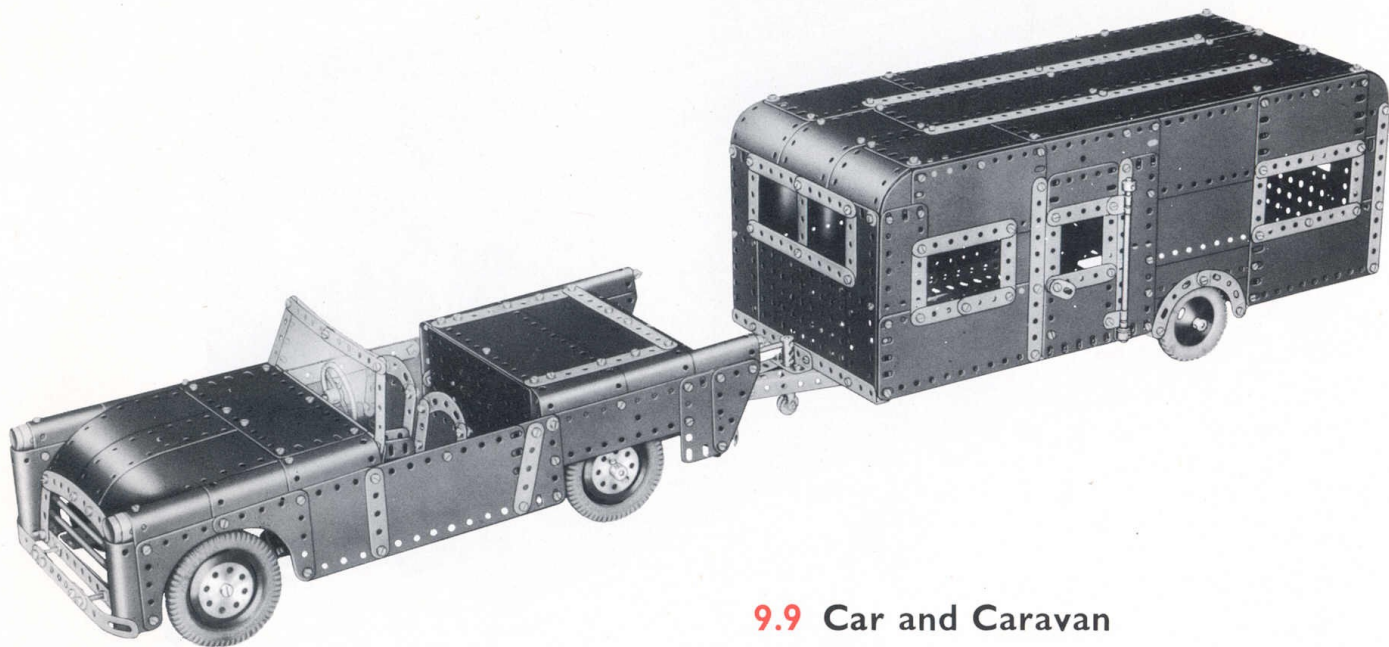

9.9 Car and Caravan

This Meccano model of a Sports Car and Caravan is driven by a Meccano No. 1 Clockwork Motor. The Motor is mounted at the rear of the car and drives through a contra wheel and pinion reduction gearing on to the rear wheels of the car. Steering is effected through a system of gears and levers controlled from the steering wheel. There is also a reversing control, which is located conveniently in the dash board, and a glazed windscreen.

The Caravan, which incorporates glazed windows and an opening door, is attached to the car by means of a towing bar and swivelling linkage gear. A small third pilot wheel on a swivel mounting is built into the chassis of the caravan so that when detached from the towing vehicle, the caravan can be manœuvred by hand.

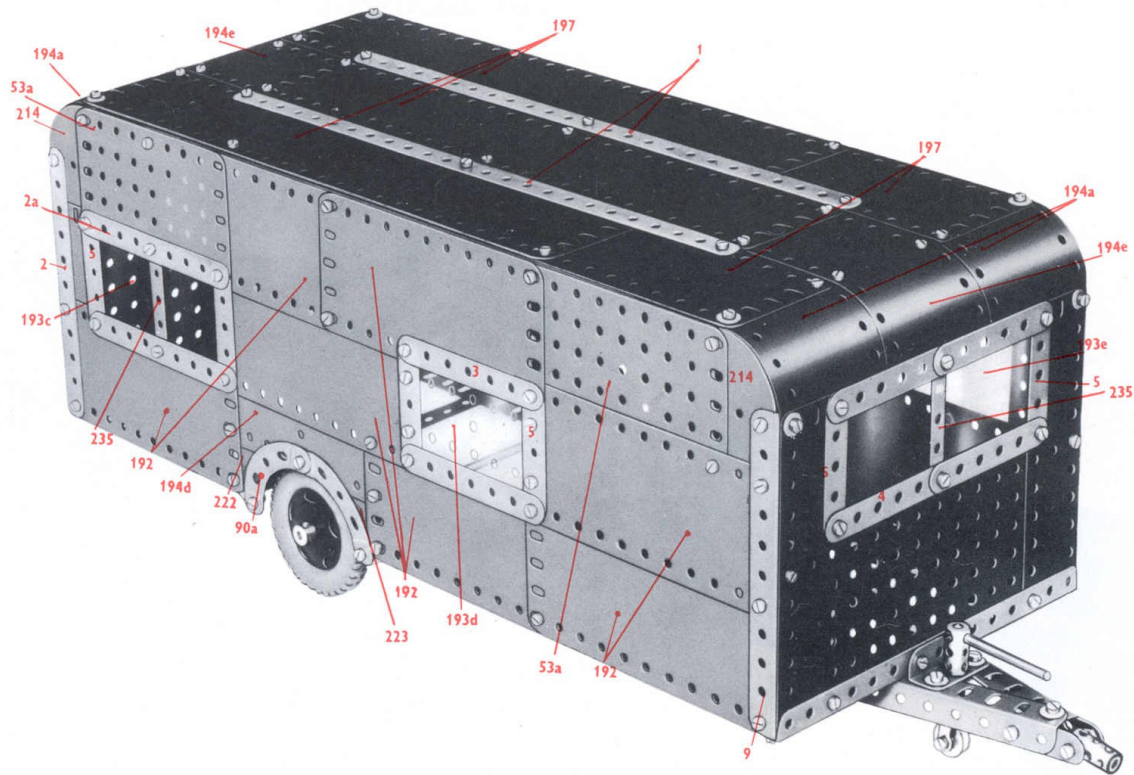

How to use this leaflet

The constructional details of the model shown in this Leaflet are explained entirely by means of half-tone illustrations and line drawings. Once the knack of 'reading' the drawings has been acquired assembly of the model will be found quite straightforward and simple to carry out.

Before starting to build the model it is advisable to study all the illustrations carefully so as to get a good idea of its various sections. Points at which various units of the model are bolted together to form the complete structure are indicated in the drawings by RED DOTS or RED BOLTHEADS whenever possible.

The particular parts used in the assembly of the model can in most cases

be identified simply by looking at the illustrations, but where the identity of a part may not be quite clear, its Part Number is printed on the model illustrations in RED. RED DOTTED pointer lines are used to indicate parts that are hidden behind other parts of the structure.

As a further help a list of the parts required to build the model is given in this Leaflet. In this list the catalogue numbers of the parts are printed in RED and the quantity of each part in BLACK.

In models fitted with a driving Motor the particular type of Motor is indicated by one of the following Code Marks: M1 = *Magic* Clockwork Motor; M2 = No. 1 Clockwork Motor; M3 = *Mecano* Electric Motor.

9.9

4	-	1	2	-	18b	2	-	70	4	-	191
2	-	1b	2	-	20	1	-	89	12	-	192
23	-	2	4	-	20a	3	-	90	2	-	193
6	-	2a	1	-	23	8	-	90a	2	-	193a
5	-	3	2	-	24	2	-	108	2	-	193c
8	-	4	2	-	24a	3	-	111	2	-	193d
27	-	5	3	-	26	2	-	111a	2	-	193e
2	-	6	1	-	27a	5	-	111c	1	-	194
5	-	6a	2	-	28	1	-	115a	4	-	194a
2	-	7a	9	-	35	1	-	116a	4	-	194c
6	-	8	337	-	37a	1	-	124	4	-	194d
2	-	8a	314	-	37b	2	-	125	4	-	194e
2	-	8b	35	-	38	1	-	128	5	-	197
2	-	9	1	-	40	4	-	142a	1	-	199
2	-	9d	2	-	48a	2	-	147b	6	-	200
2	-	9f	2	-	48b	1	-	147c	4	-	201
16	-	10	2	-	48c	1	-	154a	2	-	212a
8	-	11	2	-	48d	1	-	154b	4	-	214
1	-	11a	2	-	51	2	-	163	6	-	215
18	-	12	2	-	52	2	-	164	4	-	221
1	-	13a	4	-	52a	1	-	166	2	-	222
3	-	14	3	-	53	2	-	179	2	-	223
1	-	15	2	-	53a	1	-	185	2	-	224
2	-	15a	12	-	59	2	-	187	6	-	235
2	-	15b	2	-	62	8	-	188	2	-	235a
3	-	17	2	-	62b	8	-	189			
4	-	18a	6	-	63	10	-	190			

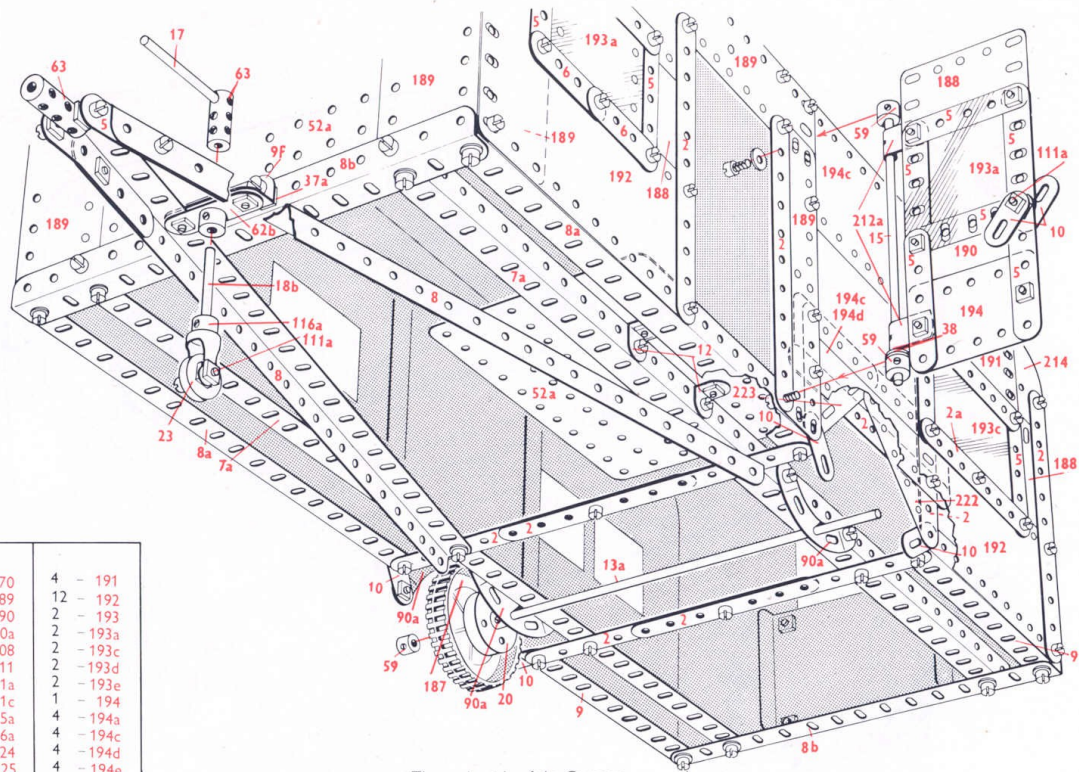

The underside of the Caravan

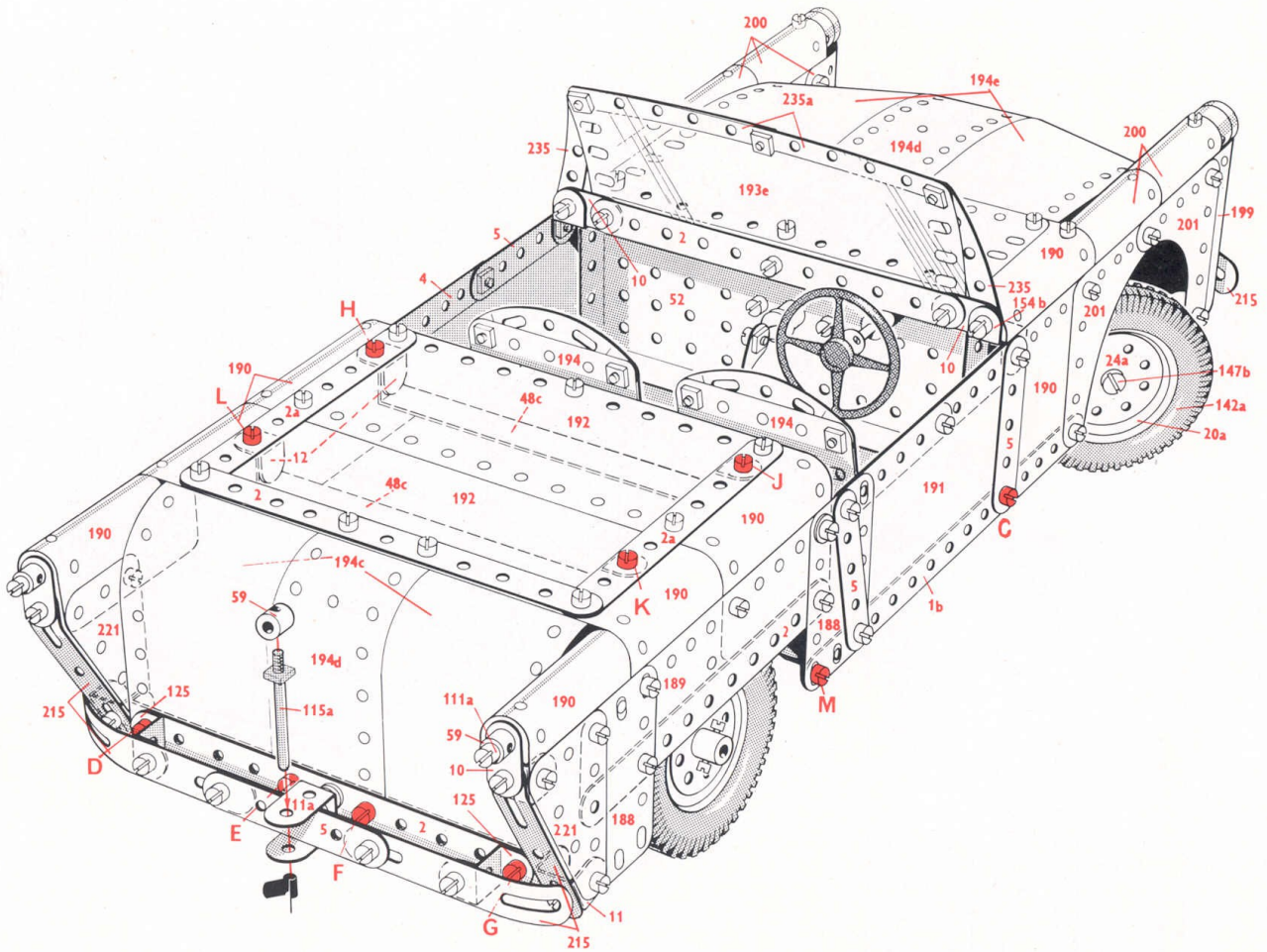

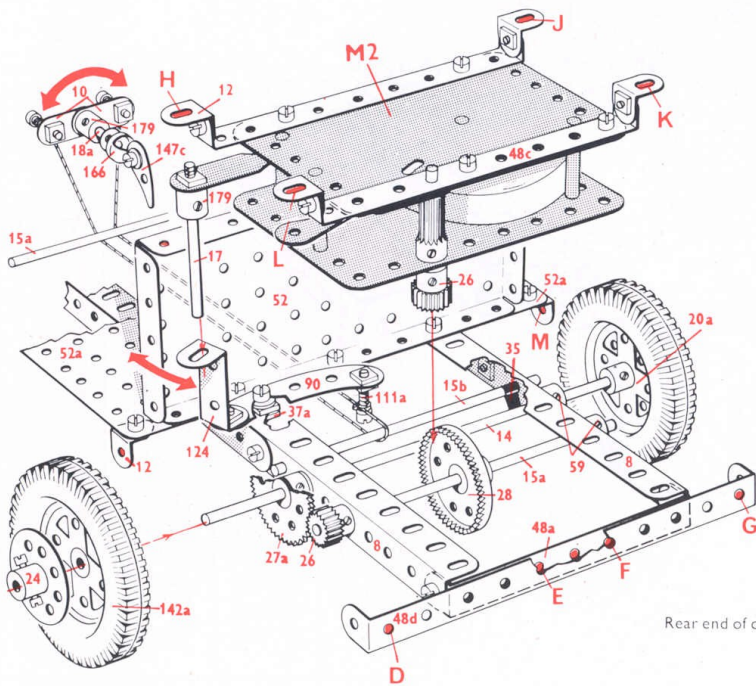

Rear end of chassis showing Motor drive

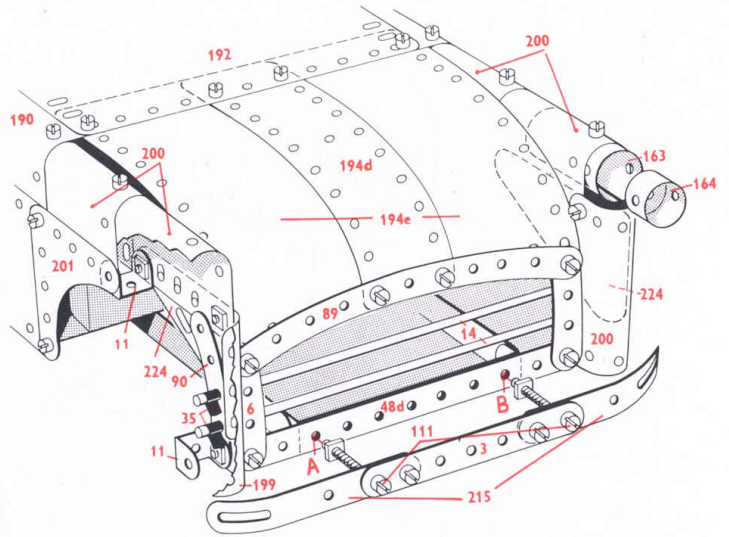

Details of the bonnet and radiator assembly

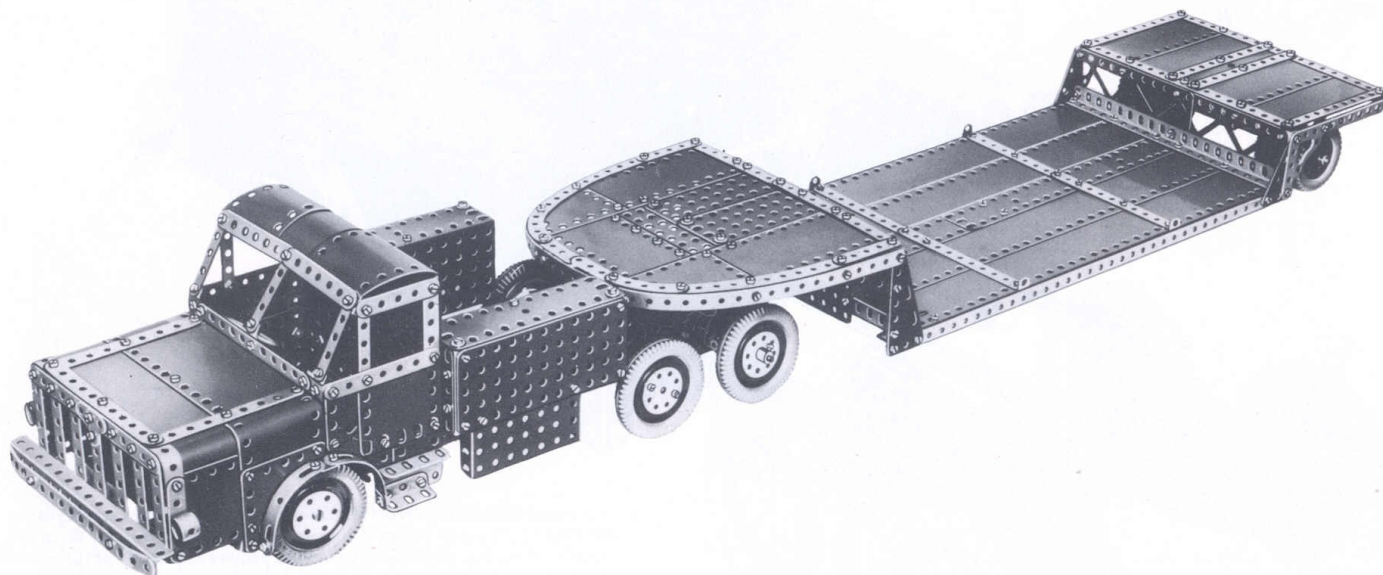

9.10 Articulated Lorry

This Meccano model of an Articulated Lorry is based on vehicles which have been designed to move exceptionally heavy and bulky loads. Such vehicles are frequently to be seen on the roads carrying large electrical transformers, ship components, boilers, earth-moving equipment and similar heavy loads. The loads may weigh anything up to 100 tons and the routes the vehicles follow have to be carefully planned in order to ensure that the roads are wide enough, and any bridges that have to be crossed strong enough, to accommodate them.

The Meccano Model is powered by a Meccano No. 1 Clockwork Motor that drives the leading pair of rear wheels of the tractor through a two-speed gear-box.

The rear wheels of the tractor are independently suspended. The rear end of the load platform is supported by four load-bearing tyred wheels, and its front end is pivotally attached to the tractor at a point centrally above the rear tractor wheels.

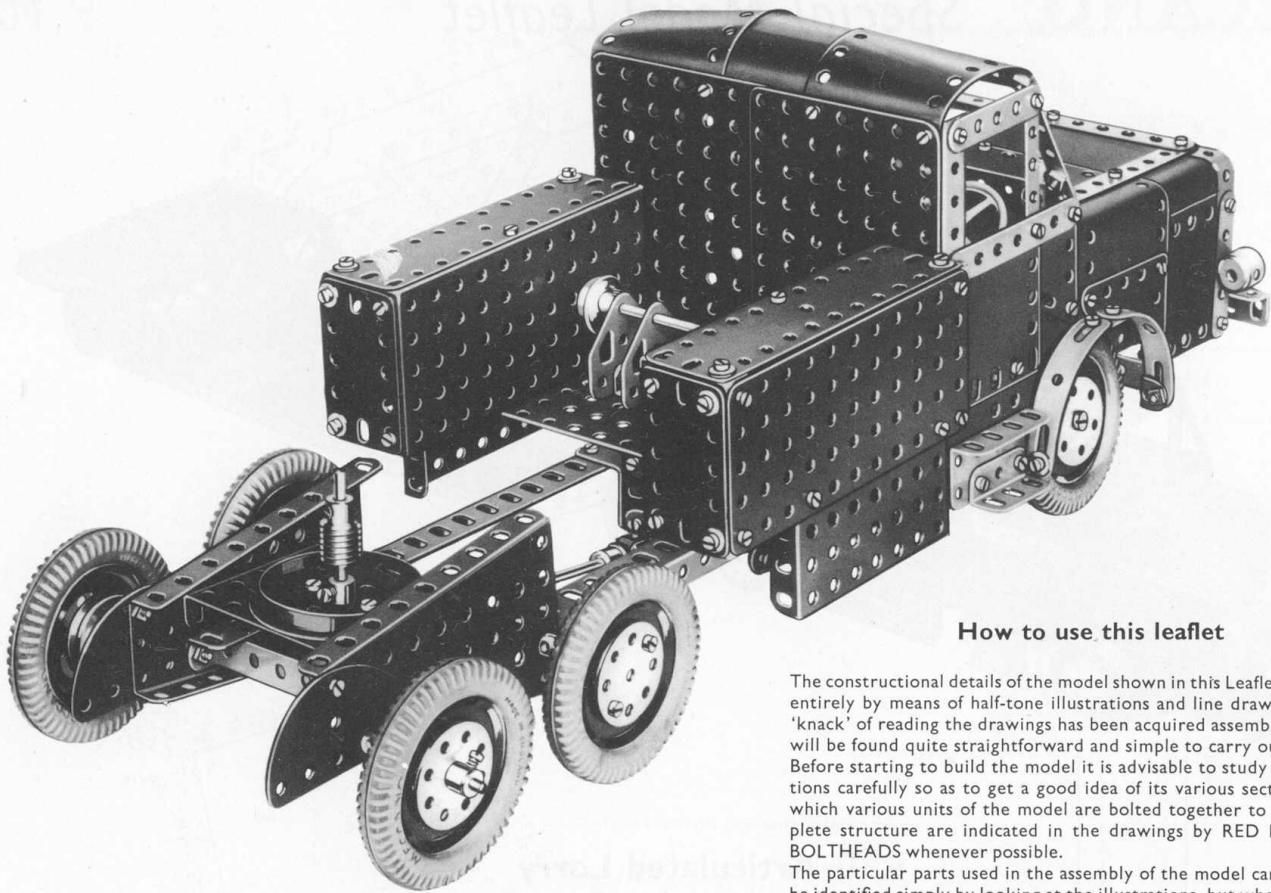

How to use this leaflet

The constructional details of the model shown in this Leaflet are explained entirely by means of half-tone illustrations and line drawings. Once the 'knack' of reading the drawings has been acquired assembly of the model will be found quite straightforward and simple to carry out.

Before starting to build the model it is advisable to study all the illustrations carefully so as to get a good idea of its various sections. Points at which various units of the model are bolted together to form the complete structure are indicated in the drawings by RED DOTS or RED BOLTHEADS whenever possible.

The particular parts used in the assembly of the model can in most cases be identified simply by looking at the illustrations, but where the identity of a part may not be quite clear, its Part Number is printed on the model illustrations in RED. RED DOTTED pointer lines are used to indicate parts that are hidden behind other parts of the structure.

As a further help a list of the parts required to build the model is given in this Leaflet. In this list the catalogue numbers of the parts are printed in RED and the quantity of each part in BLACK.

In models fitted with a driving Motor the particular type of Motor is indicated by one of the following Code Marks: M1 = *Magic* Clockwork Motor; M2 = No. 1 Clockwork Motor; M3 = Meccano Electric Motor.

Arrangement of the gear control lever

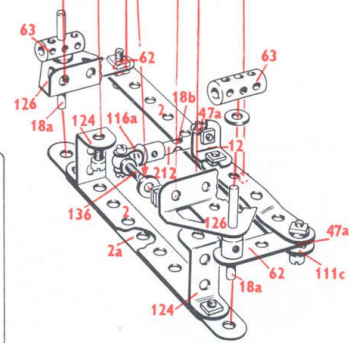
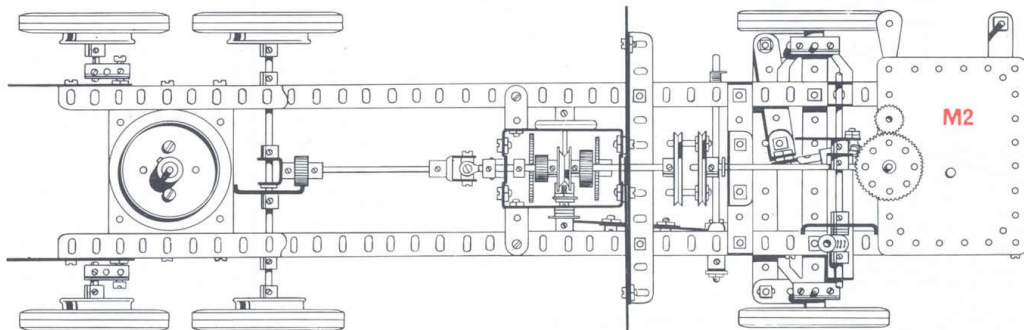
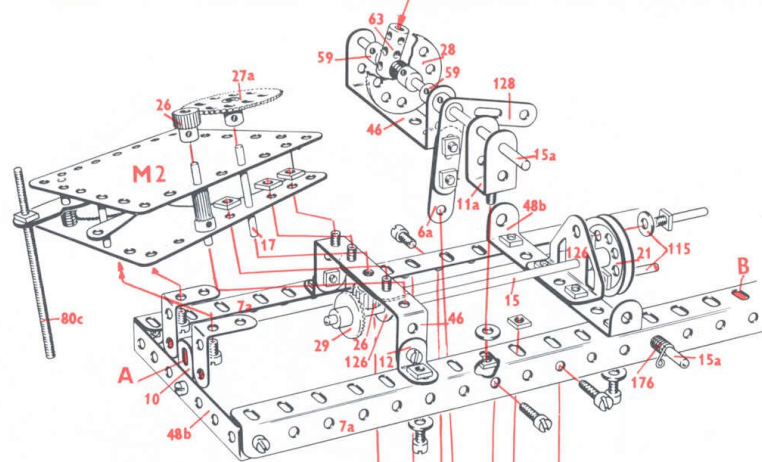
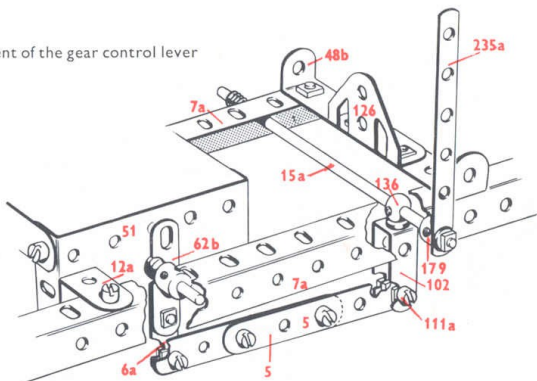

Exploded view of the front end of the Tractor unit chassis

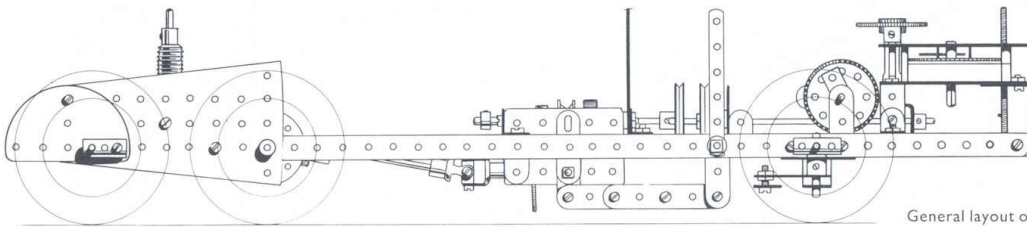

General layout of the Tractor unit chassis

Rear portion of the Tractor unit body

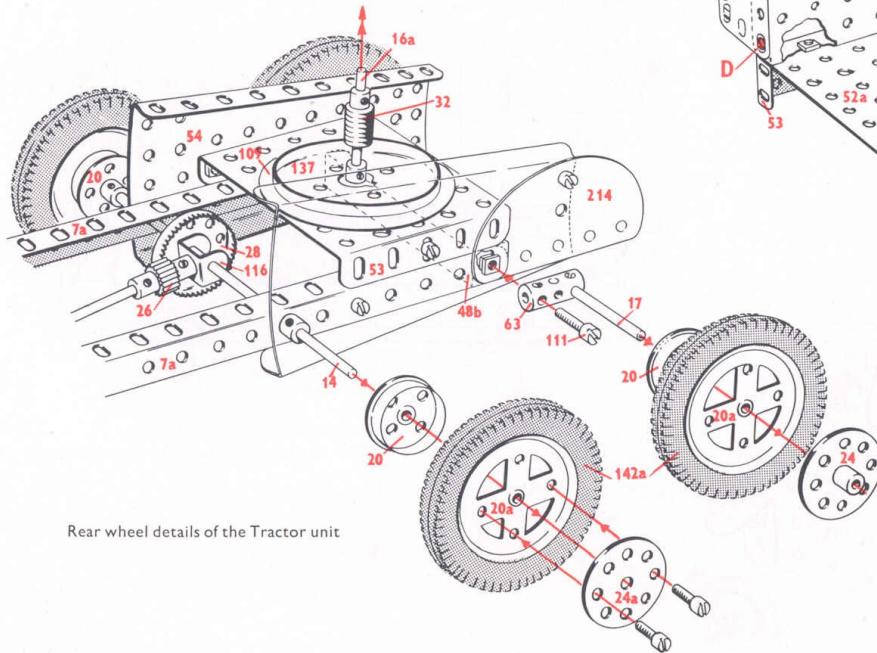
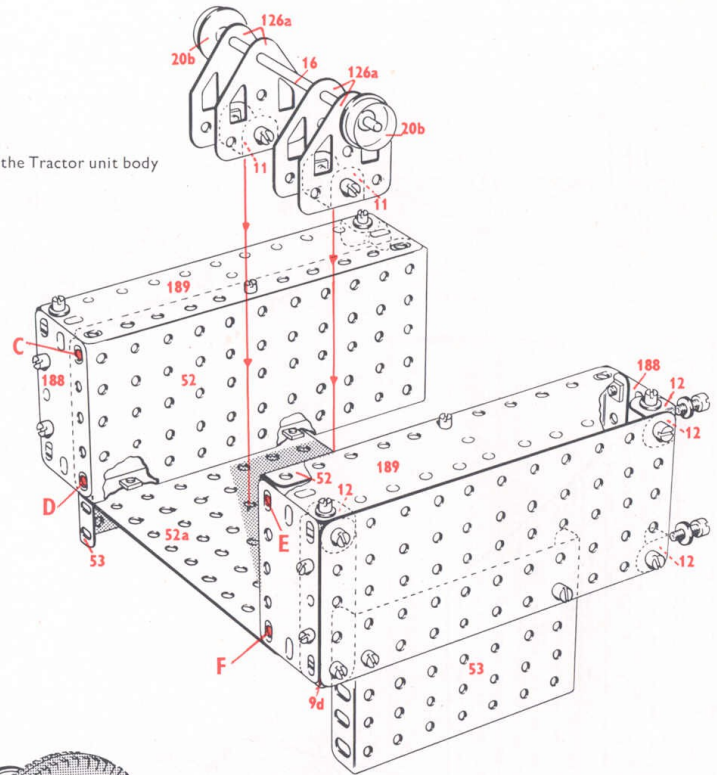

Rear wheel details of the Tractor unit

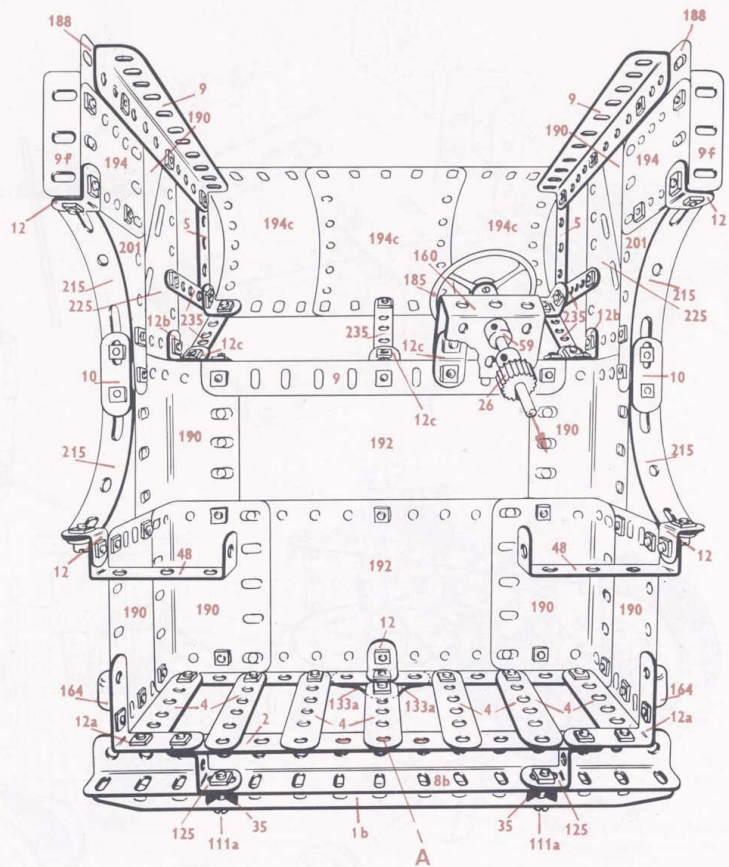
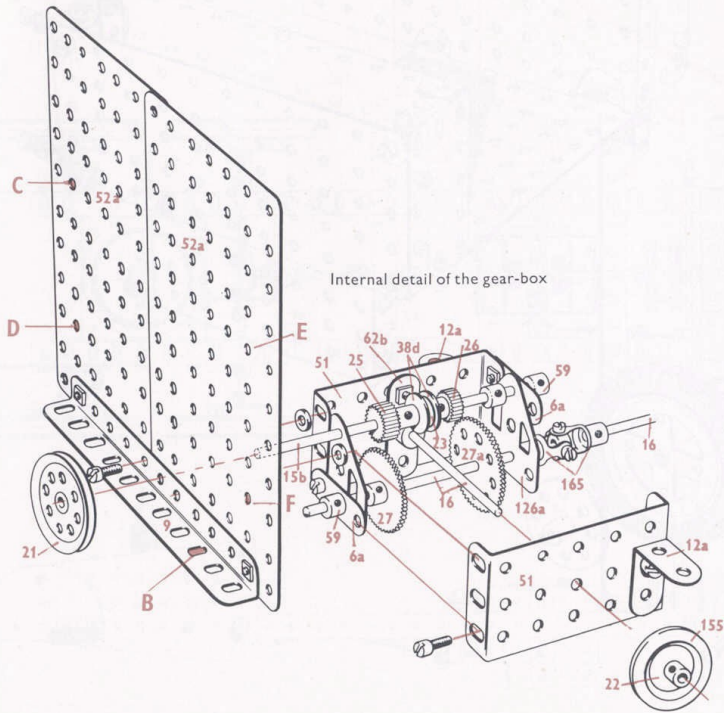

Underneath view of the cab and bonnet

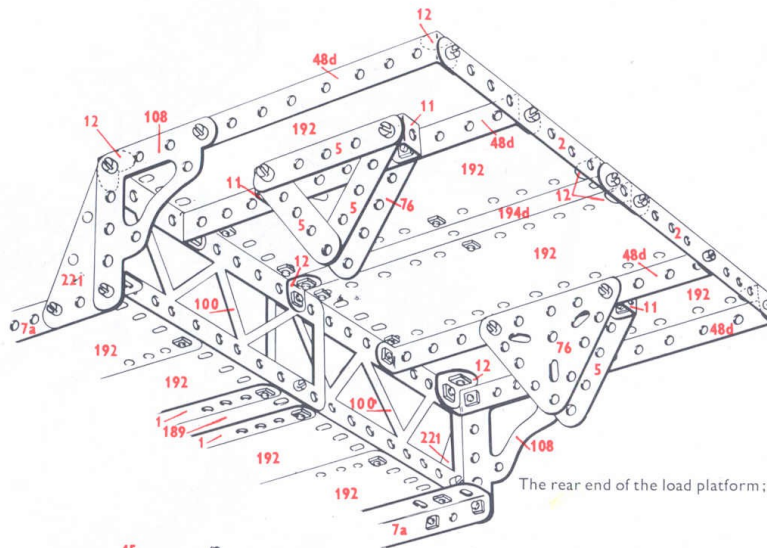

The rear end of the load platform; underneath view

Rear end of the load platform showing the road wheel arrangement

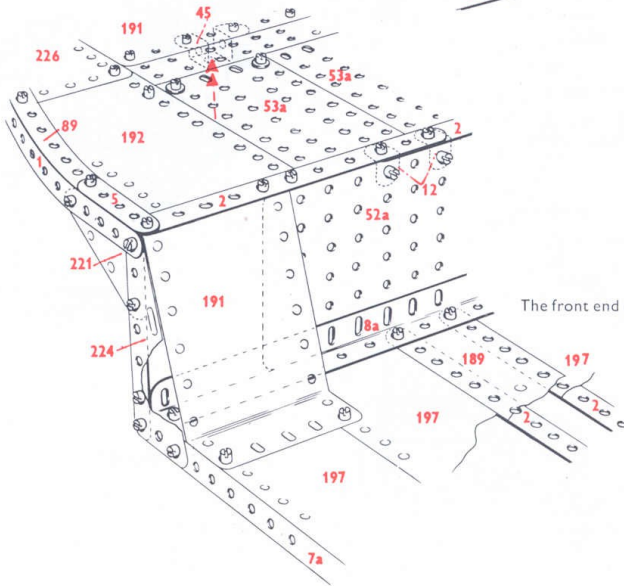
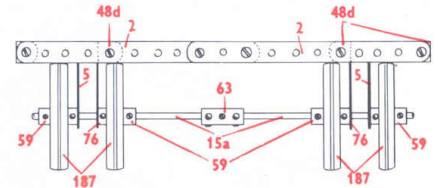

The front end of the load platform from above

9.10

4	-	1	5	-	26	2	-	124
1	-	1b	1	-	27	2	-	125
20	-	2	2	-	27a	4	-	126
3	-	2a	2	-	28	6	-	126a
6	-	3	1	-	29	1	-	128
7	-	4	1	-	32	2	-	133a
15	-	5	2	-	35	2	-	136
4	-	6	283	-	37a	1	-	137
5	-	6a	274	-	37b	6	-	142c
4	-	7a	22	-	38	2	-	147b
2	-	8a	2	-	38d	1	-	154a
1	-	8b	1	-	45	1	-	154b
3	-	9	2	-	46	1	-	155
2	-	9d	2	-	48	1	-	160
2	-	9f	3	-	48b	2	-	161
3	-	10	4	-	48d	2	-	164
6	-	11	2	-	51	2	-	165
1	-	11a	2	-	52	1	-	176
32	-	12	3	-	52a	1	-	179
6	-	12a	4	-	53	1	-	185
2	-	12b	2	-	53a	4	-	187
5	-	12c	2	-	54	2	-	188
1	-	14	11	-	59	5	-	189
1	-	15	2	-	62	8	-	190
3	-	15a	1	-	62b	3	-	191
1	-	15b	5	-	63	12	-	192
4	-	16	2	-	70	2	-	194
2	-	16a	2	-	76	3	-	194c
3	-	17	1	-	80c	1	-	194d
2	-	18a	2	-	89	4	-	197
1	-	18b	2	-	90	4	-	201
4	-	20	2	-	100	1	-	212
6	-	20a	1	-	102	2	-	214
2	-	20b	2	-	108	4	-	215
2	-	21	1	-	109	2	-	221
1	-	22	2	-	111	2	-	225
1	-	23	3	-	111a	2	-	226
2	-	24	2	-	111c	5	-	235
2	-	24a	2	-	115	1	-	235a
2	-	24c	1	-	116			
1	-	25	1	-	116a			